



The Application of Integrated Multi Trophic Aquaculture (IMTA) Using Stratified Double Net Rounded Cage (SDFNC) for Aquaculture Sustainability

Sapto P. Putro^a, Widowati^b, Suhartana^c, and Fuad Muhammad^a

^aDepartment of Biology, Faculty of Sciences and Mathematics, Diponegoro University, Tembalang, Semarang – 50275 , Indonesia

^bDepartment of Mathematics, Faculty of Sciences and Mathematics, Diponegoro University, Tembalang, Semarang – 50275 , Indonesia

^cDepartment of Chemistry, Faculty of Sciences and Mathematics, Diponegoro University, Tembalang, Semarang – 50275 , Indonesia

Corresponding author: saptoputro@undip.ac.id

Abstract - The increase of fishery production nationally and internationally may impact on the potential emergence of a variety of environmental problems. The application of sustainable aquaculture is urgently needed by breeding fish for commercial purposes in a manner such that it has a minimum impact on the environment, contributing to the development of local communities and generating economic benefits. The design of the cage and farming practice in aquaculture activities are the important steps to ensure that farming activity is still observed in order to anticipate the risk of organic enrichment caused by the activities. The application of Integrated Multi-Trophic Aquaculture (IMTA) on the Stratified Double Floating Net Cage (SDFNC) integrated with biomonitoring are an appropriate solution to the ongoing productive farming practices. IMTA is an aquaculture practice using more than one species of biotas which have ecologically mutual relationship as a part of the food chain in the area at the same time. The application of IMTA allows farmers to get several aquaculture products in the same area without increasing the horizontal area of the farms. At first, the SDFNC has been applied for farming *Cyprinus carpio* and *Tilapia niloticus* as polyculture system in freshwater ecosystem of Rawapening Lake, Central Java. Its operation has been able to increase the production capacity of at least 75% of conventional cages. The application of SDFNC-IMTA using milkfish (*Chanos Chanos*), seaweed (*Kappaphycus alvarezii*), and white shrimp (*Litopenaeus vannamei*) has been able to minimize the impact and maintain the water ecosystem in the Gulf Awerange, South Sulawesi.

Keywords : sustainable aquaculture, SDFNC-IMTA, biomonitoring, environmental impact, and water ecosystem.

Submission: August 27, 2015

Corrected : September 19, 2015

Accepted: October 12, 2015

Doi: 10.12777/ijse.9.2.85-89

[How to cite this article]: Putro, S.P., Widowati, Suhartana, and Muhammad, F. (2015). The Application of Integrated Multi Trophic Aquaculture (IMTA) Using Stratified Double Net Rounded Cage (SDFNC) for Aquaculture Sustainability, *International Journal of Science and Engineering*, 9(2),85-89. Doi: 10.12777/ijse.9.2.85-89]

I. INTRODUCTION

Indonesia has 5.8 million km² area of the territorial waters, with a coastline of 81 290 km. It is very likely to develop the aquaculture industry to be a top-3 world. However, the achievement of development results Indonesia fisheries and marine sector is seen still far from the potential of Indonesian marine disposal (Dahuri, 2015). As a maritime nation and the world's largest archipelagic sea region including ZEEI (5.8 million km²) atai 75 percent of the total area, and surrounded by 95 181 km of coastline, still need to be developed to the optimal performance. For example, the level of utilization of marine aquaculture is still in the range of 10.95 percent, while 16 percent ponds and freshwater range

from 30.17 per cent (CTF, 2013). The biggest challenge in the aquaculture sector in Indonesia is an effort to practice intensive farming of productive while remaining environmentally friendly according to the environmental carrying capacity. Sustainable aquaculture is the spirit that always need to be grown in the utilization of coastal resources.

As a maritime country, Indonesia needs to develop the aquaculture sector as a sector which has a strategic role to drive the national economy. Applications farming by utilizing the resource waters / sea very much in line with the spirit of sustainable economic program (blue economy) as a new economic paradigm to improve the welfare of the people of

Indonesi. Farming of fish, shrimp and seaweed at this time is necessary to increase the national production capacity to meet market demand. These three aquaculture products are an excellent fishery commodity demand and selling prices (economic value) is high in the export market, and demand is high for the market (consumers) in the country. Application of science and technology in the form SDFNC-IMTA is needed to implement intensive farming but still consider the carrying capacity of the environment.

IMTA is a practice farming system with more than one species of organisms that have a mutualistic relationship as ecologically as a food chain in the area / the same system at the same time. Aquaculture IMTA system allows farmers to get some aquaculture products in the same area without increasing the area of farming area. The purpose of this study is to increase the capacity of aquaculture products using SDNRC in a sustainable manner through the application of IMTA and regular biomonitoring, by then creating healthy environment for sustainable aquaculture. The SDNFC-polyculture formerly has been applied in the waters of Lake Rawapening, Central Java (Putro and Suhartana, 2008; Wijayanti and Putro, 2009), and has succeeded in increasing the production capacity of aquaculture of tilapia (*Oreochromis niloticus*) and *Cyprinus carpio* by almost double compared to conventional cage at the same horizontal extents at Rawapening Lake, Central Java. The SDNFC-polyculture has also been applied at farming areas of Gulf Awerange, Barru, South Sulawesi. The growth of main biotas representing by *Siganus sp* and *Litopenaeus vannamei* farmed exhibited faster compared to monoculture farm, owing to the relatively high values of the RGR (2.3% - 6.2%) and SGR (1.05% - 1.4%) (Putro et al, 2015).

Productivity net cage farming is determined by the design and method of application. Intensive farming is one way to increase fish production. This study is aimed to introduce a productive and sustainable farming practices by the implementation of floating net cages rounded multilevel (stratified double rounded net cage = SDNRC) applied using method of Integrated Multi-Trophic Aquaculture (IMTA) in offshore waters (off shore), thus increase the national production capacity as well as create a healthy environment and sustainable aquaculture activities.

MATERIALS AND METHOD

1. Location and installation process

Construction and installation of SDNRC-IMTA was located in the Sea Farming Karang Lebar, Kepulauan Seribu, Jakarta. The geographic location of study area was between 5°7203' - 5°7224' S, and 106°5915' - 106°5930' E of northern Jakarta.

2. Application of IMTA

Biota to be cultivated include fish rabbitfish (*Siganus sp*), tiger grouper (*Epinephelus fuscoguttatus*), seaweed (*Eucheuma cottonii*), white shrimp (*Litopenaeus vannamei*), pomfret star (*Trachinotus blochii*) / milkfish

(*Chanos-chanos* Forskal), and sea cucumbers / gamat gold (*Stichopus hermanii*). Seed fish and pomfret stars weights 250 gr KJA stocked in the lower layer with a net stocking density 25 fish / m³ with an area of 86.16 m³ net cages below. Pellets administered during the maintenance process with a protein content of 25-30% as much as 5-10% mm / day. Stocking of *L. vannamei* and *E. fuscoguttatus* conducted semi-intensive to net KJAB layer above the stocking density of 250 fish / m³ and 25 fish / m³. Parameters of physico-chemical and biological waters and sediments were measured to determine the water quality (total organic matter, ammonia, nitrite, and phosphate) and sediment (sediment grain size, total carbon, total nitrogen, and structure makrobenthos). *E. cottonii* seaweed farming will be carried out by methods vertikultur with nylon rope length vertikultur 5 m vertical to the existence KJABB, seed weight of 250 g with a spacing of 1 cm and put into a net bag size 30x50 cm. Vertikultur method is a method of farming using ropes, vertikultur method is done by tying the seeds of seaweed in a vertical position (perpendicular) to the ropes are arranged in rows, with vertikultur can also take advantage of the water column to limit water transparency. Planting will be carried out along the side of the outer KJABB 12 lines.

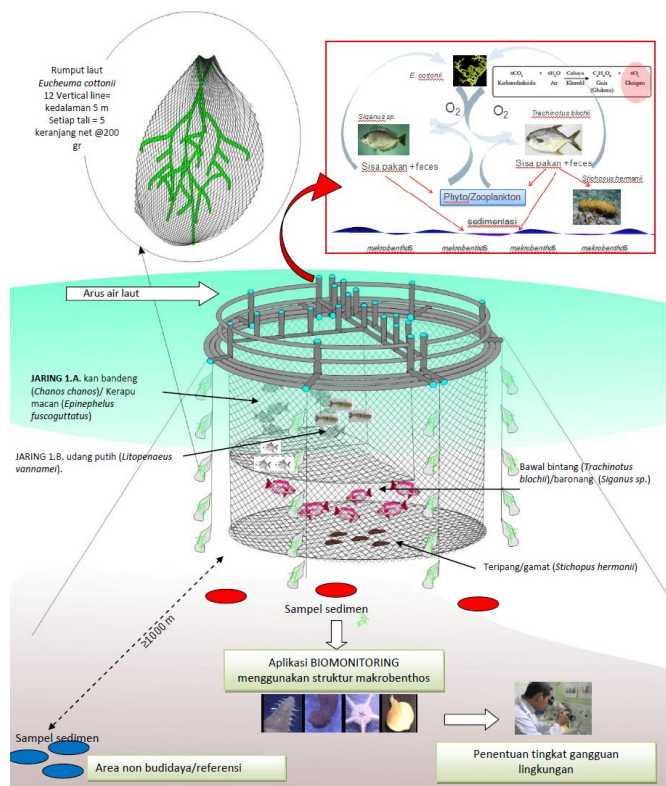

Figure 7. The concept application round floating cage (SDNRC) for integrated multi-trophic aquaculture (IMTA) integrated with biomonitoring for sustainable aquaculture.

RESULTS AND DISCUSSION

Aquaculture is not free from the constraints and problems that must be faced, among other efforts to increase

production capacity, maintain product quality prikanan, and environmental issues that can threaten the sustainability of the farming activity itself. Intensive farming is one way to increase fish production, both done in monoculture or polyculture. Along with the limited area of land or aquaculture ponds system and the potential emergence of a variety of environmental problems, the application of floating net (KJA) is a solution to increase production capacity. In recent years, fish farming KJA system is growing rapidly. KJA system of farming has become one of the solutions to the problems that often arise in aquaculture pond systems, namely the flooding due to the high intensity of rainfall in certain seasons and climate change so as to eliminate the / sweep biota farming. One effort to increase production capacity without increasing the area of farming area horsional system KJA KJA is modified into a floating net-rise (KJAB) (Putro and Suhartana 2008; Wijayanti and Putro, 2009). Application development of fish farming cages multilevel system has been tested in freshwater periaran (Putro and Suhartana 2008) and sea (Sudaryono et al., 2013; Sudaryono et al., 2014). Installation of floating net cages has been done in cooperation with as many as



Figure 3. Installation KJABB - IMTA in sea farming region Reef Width , Kpeulauan Thousand ; A. Foot step with rounded bench along the outer circle KJA ; B. Net roller to steer connected by PE rope with a net over

The cage is fitted with a pair of roller net with steer connected by PE rope with a net above, serves to facilitate the harvesting good for biota farming in the top and bottom webs. Operations are easy and practical, just rotated clockwise a particular advantage of this design. Made from HDPE / polyethylene that has SNI (No.06-4829-2005), cage construction of SDNRC-IMTA is very strong and elastic, resistant currents and waves. At the foot step position that also serves as a float, have been installed along the outer circle rounded bench KJA dg convenient hand-held size, function other than as protection as well as to handle the process of harvesting or emergency conditions. In its application, the farming system Integrated Multi-Trophic

Aquaculture (IMTA) can be applied to KJABB in offshore waters. This may be one solution that is appropriate to the productive and sustainable farming practices. Aquaculture IMTA system allows farmers to get some aquaculture products in the same area without increasing the area of farming area. For example, the farming of which is integrated in floating net cages KJABB-IMTA, milkfish (*Chanos Chanos*), seaweed (*Kappaphycus alvarezii*), and white shrimp (*Litopenaeus vannamei*) is integrated with the application of biomonitoring able to drive the optimization of production in the Gulf Awerange, South Sulawesi (sudaryono et al., 2014). The integration of seaweed into polyculture of shrimp and fish activities in an integrated manner is one of the proper application. Tiger shrimp, fish and seaweed biologically have properties that can work together so that polyculture farming of this kind can be developed because it is a form of polyculture farming friendly to the environment. Seaweed is a supplier of oxygen through photosynthesis during the day and has the ability to absorb excess nutrients and toxic contaminants in the waters. While the plankton-eating fish as a controller to an excess of plankton in the water. Dirt shrimp, fish and other organic matter is a source of nutrients that can be utilized by seaweed and phytoplankton for growth . Relationship as shown in Figure 4 below can balance the aquatic ecosystem .

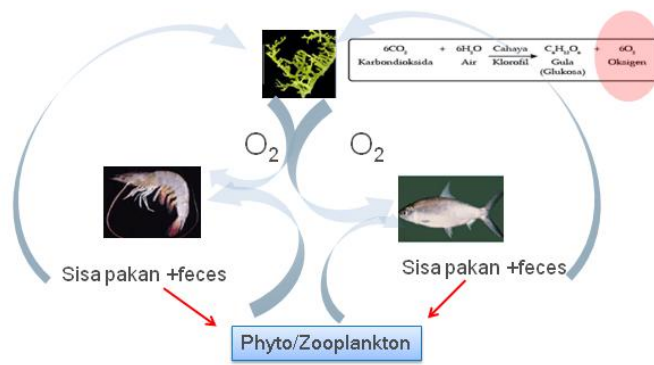

Figure 4. Mutualistic relationship and the flow of energy in the application system Keramba cage cages Storey (KJABB - IMTA) as marine fisheries commodities : seaweed (*Kappaphycus alvarezii* Doty), white shrimp (*Litopenaeus vannamei* Boone), milkfish (*Chanos Chanos*) (Putro et al., 2015)

Understanding of the environmental management is needed by the industry , especially those engaged in the field of freshwater and marine aquaculture . One satau output of these research activities is the right method , rapid and relatively low cost in determining the quality of the environment . In the long term , the improvement of environmental quality will gradually be able to increase the carrying capacity (carrying capacity) of farming area , up will improve the ability of farmers in producing quality fish and indirectly improve the welfare of the farmers ponds and cages.

Floating net-cage (SDNC) has been applied in the waters of Lake Rawapening, Central Java (Putro & Suhartana, 2008; Wijayanti and Putro, 2009), and has managed to increase the production capacity of aquaculture of tilapia (*Oreochromis niloticus*) and carp (*Cyprinus carpio*) doubled compared to the same horizontal extents (4 x 8 m²) (Putro & Suhartana, 2008).

The main obstacles encountered in the early stages of SDNC applications is the difficulty in the extraction / harvesting of fish in the nets above bawah. Jaring difficult to be lifted, in particular due to the net burden on the partly covered by sedimentation. Based on the problems in the field, the modification SDNC shaped swath will be transformed into a round shape and added SDNC roller, especially the changing design of nets below the level by adding net roller, allowing the net can be rolled down freely so that the fish will be lifted when the time of harvesting. Applications SDNC-IMTA believed would ensure continuity of activities can be run gradually transferred to stakeholders (exit strategy), ie the group of farmers. Together with partners, this practice is expected to be implemented on a wider scale through public policy that is expected to be able to change people's behavior and management of aquaculture in a spirit of mutual cooperation in accordance with the character of the nation. In addition, farming SDNC-IMTA system is believed to be able to increase production capacity without increasing the area of the horizontal area of farming, farming of organisms have a mutualistic relationship that is mutually beneficial, thus improving the efficiency of feeding as well as reduce organic waste as a result of aquaculture activities.

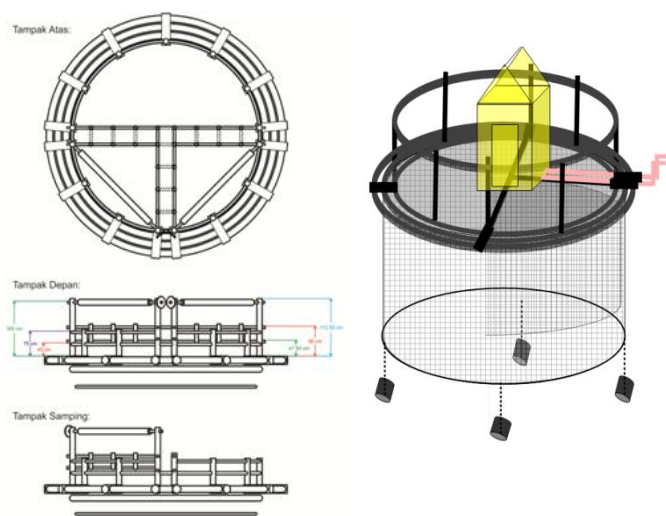

Figure 5. Design of floating rounded net - cage SDNRC-IMTA (patent application No : S00207106486 2014).

In the implementation, development, design and installation SDNRC-IMTA can be done with the community farmers, for example with the application of farming of milkfish (*Chanos Chanos*), seaweed (*Eucheuma cottonii*), and white shrimp (*Litopenaeus vannamei*). Optimization of production focused on the quality and quantity of life of farming and farming of environmental quality through the application of biomonitoring. Dissemination of the results of the application can be implemented on a wider scale to the group of fish farmers (Putro et al., 2015).

Dissemination and application of SDNRC-IMTA at national scale may cooperate with governmental bodies , and the analysis of the prospects / product marketing opportunities and market absorption (Market Acceptance) . Prospects and market absorption can be made after analysis of the trial . Stages of analysis includes a survey of farmers demand for design and application of the cage, consumer tastes ,

consumer behavior , abilities (knowledge and financial). Market absorption of the product will be determined based on market demand, in particular semi-intensive farmers , offers opportunities , market space and market share .

CONCLUSIONS

Applications floating rounded cages SDRNC-IMTA integrated with biomonitoring technique is believed to be the right solution towards a sustainable productive farming practices. The farming practices in accordance with current needs, particularly efforts to increase the productivity of aquaculture with regard to the carrying capacity of the environment. The application of biomonitoring in aquaculture activities is an important step to ensure that farming activity still observed that anticipatory measures against the risk of interference can be reduced and anticipated environment.

ACKNOWLEDGEMENT

We would like to thank Ministry for Research, Technology, and Higher Degree (Simlitabmas - RISTEKDIKTI) for supporting research on the development of sustainable productive aquaculture through funding the research grant under the scheme National Strategic Research -PUSNAS year period 2015- 2017 .

REFERENCES

- Clarke, K.R. and Warwick, R.M. 2001. Change in marine communities: an approach to statistical analysis and interpretation. PRIMER-E Ltd, Plymouth.
- Dahuri, 2015). Perikanan budidaya seharusnya diutamakan. Antara News. Accessed on 11 October 2015. Website: <http://www.antaranews.com/berita/502170/rokhmin-dahuri-perikanan-budidaya-seharusnya-diutamakan>
- Dahuri, R. 2012. Cetak Biru Pembangunan Kelautan dan Perikanan : Menuju Indonesia yang Maju, Adil-Makmur dan Berdaulat. Roda Bahari. Bogor.
- Diaz R. J. dan Rosenberg R. (1995) Marine benthic hypoxia: a review of its ecological effects and the behavioural responses of benthic macrofauna. *Oceanography and Marine Biology: an Annual Review* 33: 245-303.
- Dinas Kelautan dan Perikanan Provinsi Jawa Tengah.2014. Buku Saku Dinas Kelautan dan Perikanan Provinsi Jawa Tengah, Pemerintah Provinsi Jawa Tengah.
- Food and Agriculture Organization (FAO). 2010. The State Of World Fisheries and Aquaculture 2010.
- Food and Agriculture Organization (FAO). 2014. The State Of World Fisheries and Aquaculture 2014.
- Kementerian Kelautan dan Perikanan, 2013. Laporan Kinerja (LAKIP) Kementerian Kelautan Dan Perikanan Tahun 2014
- Pawar, V., Matsuda, O., and Fujisaki, N. 2002. Relationship between feed input and sediment quality of the fish cage farms. *Fisheries Science* 68: 894-903.
- Pearson, T. H. and Black, K. D. 2001. The environmental impacts of marine fish cage culture. In: *Environmental impacts of aquaculture* (ed. K. D. Black). Sheffield Academic Press Ltd, Sheffield, pp. 1-31.
- Porrello, S., Tomassetti, P., Manzueto, L., Finoia, M. G., Persia, E., Mercatali, I., and Stipa, P. 2005. The influence of marine cages on the sediment chemistry in the Western Mediterranean Sea. *Aquaculture*, 249: 145-158.
- Putro , S.P., Widowati, Suhartana, dan Muhammad, F. 2015. Aplikasi keramba jaring apung bertingkat sistem Integrated Multi Trophic Aquaculture (SDNC-IMTA) terintegrasi biomonitoring menuju Industri Akuakultur Indonesia Berkelanjutan. *Proceeding Seminar Nasional Biologi II. Fakultas Sains dan Matematika Universitas Diponegoro*. Semarang, 6 Agustus 2015.
- Putro S.P. dan Suhartana. 2008. Rehabilitasi dan Optimalisasi Pemanfaatan Sumber Daya Alam Kawasan Rawapening Dengan Menerapkan Manajemen Lingkungan dan Ecological Engineering Dalam Upaya Meningkatkan Kesejahteraan Masyarakat. *Laporan KKN PPM –DP2M DIKTI, LemlitUndip*. Semarang.

- Putro, S.P. 2013. The Development Biomonitoring Method Used For Environmental Disrubance Assessment Under Fish Farms Using Macrobenthic Structure At Lake Rawapening, Central Java. Proceeding of Workshop on Lake Danau Rawapening, 13 June 2013, Hotel Ciputra Semarang.
- Putro, S.P. and Svane, I. 2005. Effects of fallowed fish farms on macrobenthic assemblages – a full year assessment. In Proceeding of Aquafin CRC 2005 Conference (pp. 18-19). Hobart, Australia, July 5-7, 2005.
- Putro, S.P., Svane, I., and Tanner, J. 2006. Effects of fallowing on macrobenthic assemblages in sediments adjacent to southern bluefin tuna cages. In : Final report of Aquafin CRC-Southern bluefin tuna aquaculture: evaluation of waste composition and waste mitigation. FRDC Project No. 2001/103/2006. SARDI Aquatic Sciences, Adelaide. pp. 243-282.
- Putro, S.P., Widowati, Suhartana, and Muhammad, F. 2015. The Application of Integrated Multi Trophic Aquaculture Using Stratified Double Net Cage for Aquaculture Sustainability. *International Journal of Science and Engineering (IJSE)*, 8 (3): xx-xx (*In press*).
- Schendel, E. K., Nordstrom, S. E. and Lavkulich, L. M. 2004. Floc and sediment properties and their environmental distribution from a marine fish farm. *Aquaculture Research*, 35: 483-493.
- Sudaryono, A., Putro, S.P., Suminto, dan Asmi Citra Malina. 2013. Pengembangan Teknik Budidaya, Diversifikasi Produk, Dan Pengelolaan Lingkungan Sektor Perikanan Budidaya Untuk Mendukung Ketahanan Pangan Nasional. Laporan Akhir Tahun 1 Penelitian Prioritas Nasional Masterplan Percepatan Dan Perluasan Pembangunan Pembangunan Ekonomi Indonesia 2011 – 2025 (Penprinas MP3EI 2011-2025). Lembaga Penelitian dan Pengabdian kepada Masyarakat, Universitas Diponegoro, Semarang.
- Sudaryono, A., Putro, S.P., Suminto, dan Asmi Citra Malina. 2014. Pengembangan Teknik Budidaya, Diversifikasi Produk, Dan Pengelolaan Lingkungan Sektor Perikanan Budidaya Untuk Mendukung Ketahanan Pangan Nasional. Laporan Akhir Tahun 2 Penelitian Prioritas Nasional Masterplan Percepatan Dan Perluasan Pembangunan Pembangunan Ekonomi Indonesia 2011 – 2025 (Penprinas MP3EI 2011-2025). Lembaga Penelitian dan Pengabdian kepada Masyarakat, Universitas Diponegoro, Semarang.
- Undang-Undang Nomor 17 Tahun 2007 tentang Rencana Pembangunan Jangka Panjang (RPJP) Nasional 2005-2025.
- Undang-undang Nomor 27 Tahun 2007 tentang Pengelolaan Wilayah Pesisir dan Pulau-pulau Kecil (PWP-PK).
- Warwick, R. M. and Clarke, K. R. 1993. Increased variability as a symptom of stress in marine communities. *Journal of Experimental Marine Biology and Ecology*, 172: 215-226
- Wijayanti, D.P dan Putro, S.P. 2009. Optimalisasi Pembedayaan Masyarakat Desa Asinan, Kecamatan Bawen, Kabupaten Semarang Melalui Pengembangan Teknik Budidaya Sistem Keramba Apung Dan Peningkatan Mutu Pakan Ikan. Laporan KKN PPM –DP2M DIKTI, Lemlit Undip. Semarang.
- Wurtz, W.A. 2006. Sustainable Aquaculture; Concept and Practice. *Biotechnology*, Vol X; 1-15.