



## Production of Furfural from Corncobs Agricultural Waste by Acid Hydrolysis at Atmospheric Pressure

Catur Rini Widyastuti<sup>1✉</sup>, Istiqomah<sup>2</sup>

DOI 10.15294/jbat.v3i2.5765

Prodi Teknik Kimia, Fakultas Teknik, Universitas Negeri Semarang, Indonesia

### Article Info

*Sejarah Artikel:*  
Diterima Oktober 2015  
Disetujui Desember 2015  
Dipublikasikan Desember 2015

*Keywords:*  
Biodegradable foam,  
baking process, magnesium stearat, protein.

### Abstract

Corncob is the renewable agricultural biomass which has great potency to be developed into useful chemical. It can be used as raw material for producing furfural as it contains high concentration of pentosan up to 32%. Furfural is a useful chemical intermediate which may be further processed into other valuable products, such as furan, furoic acid, and furfuryl alcohol. Furfural is also an important chemical solvent. The aim of this research was to optimize the production process and maximize the yield of furfural. The research was conducted in three steps which included pretreatment of raw material, hydrolysis, and distillation. Corncobs was ground to form powder with a maximum particle size of 150 mesh and then hydrolysed in a stirred reactor using H<sub>2</sub>SO<sub>4</sub> at temperature variation of 80oC, 90oC, and 100oC for 2 hr, 3 hr, and 4 hr at atmospheric pressure. The hydrolysate was filtrated and the filtrate was added by toluene and being kept for 12 hours. The product was separated by distillation at 110oC. The result showed the highest yield of furfural from corncobs was 31% which obtained by acid hydrolysis at 100oC for 4 hours. Analysis using GC-MS identified furfural in the product and several impurities, such as toluene, 1,5-heptadien-3-yne, and benzaldehyde.

## INTRODUCTION

Furfural is one of chemical intermediate used as feedstock for making tetrahydrofurfuryl alcohol (THFA) and other furan chemicals, such as furoic acid and 5-hydroxymethyl furfural (5-HMF) which is an important organic compound for production of renewable plastics (Iryani, 2013). Furfural or often called as 2-furancarboxaldehyde, 2-furaldehyde, furfurylaldehyde, furale, 2-furanaldehyde, is a chemical compound produced via acid-hydrolysis and dehydration of pentoses. Furfural is a heterocyclic aldehyde with chemical formula of  $C_5H_4O_2$  as shown by Figure 1, a colorless oily liquid with the odor of almonds (Hawleys, 1971).

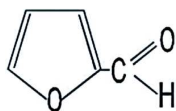

**Figure 1.** Molecule structure of furfural

Furfural can be produced from biomass containing pentosan via two steps of reactions, hydrolysis and dehydration which catalysed by acid, such as  $H_2SO_4$ , HCl, etc (Sangarunlet, 2007). Pentosan is a compound of polysaccharide group which can be hydrolysed into monosaccharides with five carbon atoms so called pentose. If hydrolysis is continued by heating in sulfuric acid solution or chloride acid for 2-4 hours, pentoses release three water molecules and form furfural.

According to data provided by Ullmann (2000), corncobs contain pentosan up to 32% of its dry weight. Therefore, corncobs are potential as feedstock for producing furfural. Not to mention, it will be a solution for the problem related to agricultural waste. Even though the production of furfural generates residues during the separation process, it can be converted into another valuable product. According to experiment done by Ali et al., 2002, the residue after extraction can be directly activated at  $700^\circ C$  to produce active carbon whose quality is comparable with the commercial one.

Furfural production process is affected by several factors including catalyst concentration, reaction temperature, pressure, time, agitation, liquid and solid ratio, and size of raw material. Sangarunlet et al. in their experiment of furfural production by hydrolysis accompanying supercritical  $CO_2$  extraction from rice husk, investigated the effect of several parameters to the production process using two-level fractional design method. The results obtained from the experimental de-

sign showed that increasing temperature, pressure,  $CO_2$  flow rate and sulfuric acid concentration but decreasing ratio of liquid to solid would improve furfural yield (Sangarunlert, 2007). The aim of this research was to find the optimum furfural production process from corncobs at atmospheric pressure which lead high furfural yield.

## METHODS

### Materials

Corncobs provided by the farmer in Brebes, Central Java, Indonesia was ground using a cutting mill to form powder with a maximum particle size of 150 mesh. The powder was then dried in an oven at  $60^\circ C$  for 6 hours so that it resulted in water content of which reached 8% dry weight before commencing treatment.

### Methods

The experiments were done in a batch-type reactor equipped with thermometer and agitator (see Figure 2). The experiments were conducted in four steps including pretreatment of raw material, hydrolysis, separation process, and furfural analysis.

#### Hydrolysis

As much as 5 grams of corncobs powder were hydrolysed with 150 mL of 1.5 M  $H_2SO_4$ . The reaction was carried out in a stirred refluxed-reactor equipped with thermometer and condenser at temperature variation of  $80^\circ C$ ,  $90^\circ C$ ,  $100^\circ C$  for 2, 3 and 4 hours at atmospheric pressure.

#### Separation Process

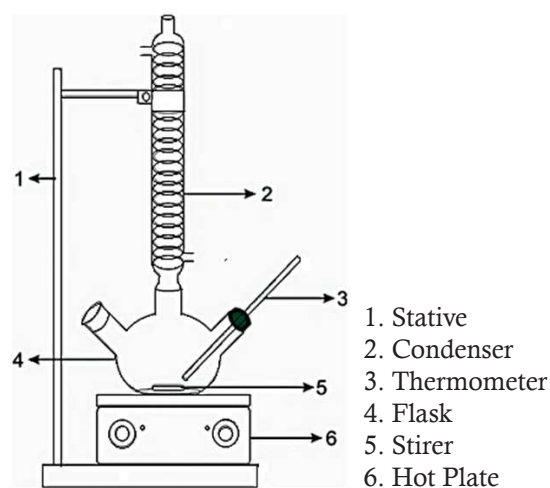

**Figure 2.** A set of refluxed apparatus

The hydrolysate was filtrated and the toluene was added into filtrate with ratio of 1:1. Separation of air-furfural-toluene was conducted

by decantation for 12 hours which resulted the furfural-toluene at upper layer. Then, an anhydride  $\text{Na}_2\text{SO}_4$  was added to the mixed of furfural-toluene to remove the remaining water content. After removing the anhydride by filtration, the mixed of furfural-toluene was distilled at  $110^\circ\text{C}$ . The resulted furfural was brown-yellow liquid.

**Furfural Analysis**

Analysis was done qualitatively by adding reagent to the obtained furfural sample. The reagent used to analyse furfural was mixed of acetic acid and aniline with ratio of 1:1. If the sample contains furfural, the colour changed to red. Another analysis using GC-MS was done to identify the sample component.

**RESULTS AND DISCUSSION**

Before being hydrolysed, the corncobs were resized to 150 mesh and dried to remove the water content up to 8%. As the size of raw material is reduced, the area increases so that improves contact between the reacted molecules. This is according to Arrhenius equation, by reducing size of particles, the pre-exponential factor, A, is larger which result in larger value of rate constant, k (Andaka, 2011).

Furfural was produced via hydrolysis of pentosan and dehydration using acid catalyst. The acid used in the experiment was sulfuric acid which according to Ambalkar et al., sulfuric acid

shows more yield of furfural than hydrochloric acid (Ambalkar, 2012). During hydrolysis, pentoses bind the OH group from water molecule. Whilst during dehydration reaction, the water molecule was released by furfural. In acid condition, pentoses will release three molecules of water and form furfural. The reaction occurs according to the following equations:

Hydrolysis of pentosan into pentoses:

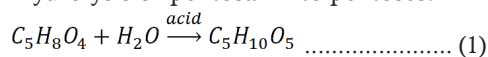

Dehydration of pentoses into furfural:

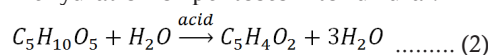

In the experiments, ratio of corncobs powder to  $\text{H}_2\text{SO}_4$  catalyst was 1:30. As suggested by Setyadji et al. (2007), by increasing ratio of catalyst to the powder, the yield of furfural increases. This is due to the rate of reaction increases with higher concentration of acid as the catalyst reduces the activation energy.

**Furfural Identification**

The obtained furfural was analysed qualitatively using aniline-acetic anhydride and its component was identified using GC-MS. From the analysis results showed that all of samples changed to red when aniline acetate was added. Change of colour from brown-yellow to red by adding aniline acetate is caused by condensation

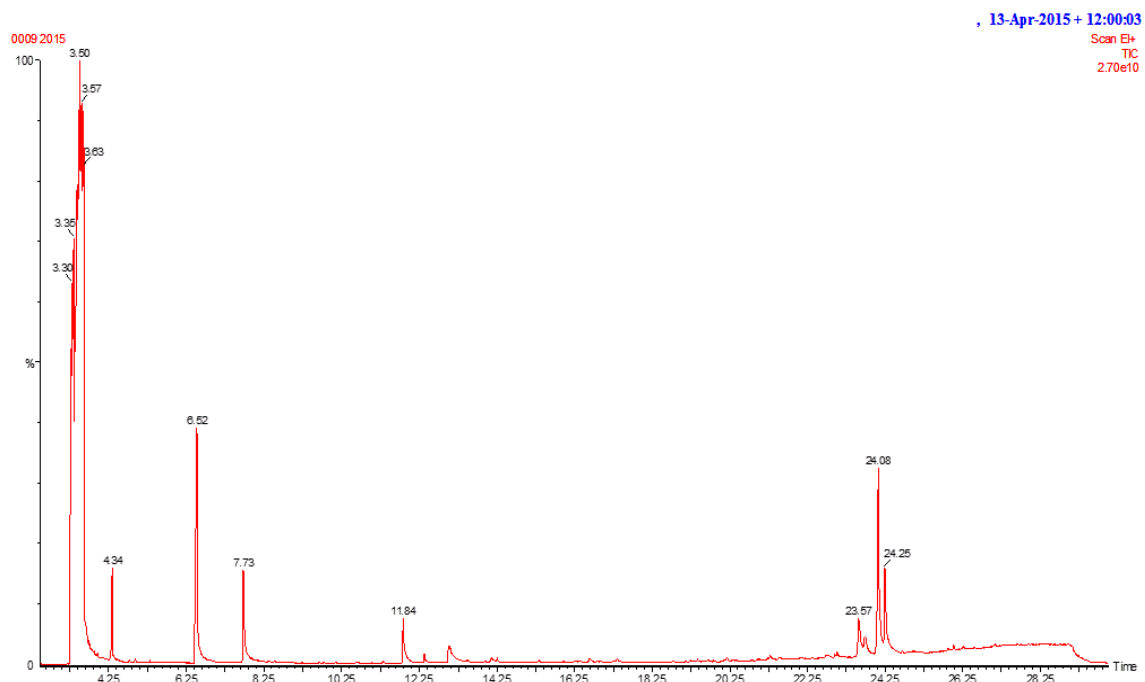

**Figure 3.** GC-MS chromatograph of the resulted furfural

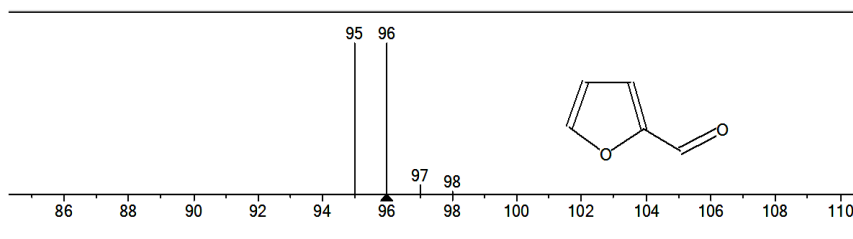

Figure 4. Fragmentation pattern of furfural

Table 2. Yield of furfural from experiments

Temperature (OC)	Time (hour)	Mass of sample powder (gram)	Furfural residue (gram)	Yield (%)
80	2	5	1,18	23,6
	3	5	1,25	25
	4	5	1,45	29
90	2	5	1,31	26,2
	3	5	1,5	30
	4	5	1,25	30
100	2	5	1,49	29,8
	3	5	1,51	30,2
	4	5	1,55	31

reaction of furfural with aniline to form hydroxy glutamic aldehyde which occurs in two steps. The first step is reaction with aniline resulting yellow colour, then reacts further with the second aniline which breaks the furfural rings and forming dialdehyde. Formation of hydroxy glutamic compound from reaction resulting red colour (Hidajati, 2006).

Another identification using GC-MS confirmed that the hydrolisate contains furfural. The compound is shown by gas chromatography with Retention Time (RT) 4.344 (Fig.3). According to mass spectrophotometer, the obtained furfural has relative molecular mass of 96, which is shown by fragmentation pattern of furfural in the GC-MS library (Fig. 4).

From Figure 3, analysis using GC-MS identified furfural compound and the impurities, such as toluene, 1,5-heptadien-3-yne, and benzaldehyde.

#### Effect of Reaction Temperature and Time toward Yield of Furfural

The experiments were done by varying variables of temperature and time, while the amount of corncobs powder, catalyst concentration, and speed of stirring were set constant as described earlier. The yield of fufural from the experiments are shown in Table 2, which the graph of relati-

on between temperature and reaction time can be seen in Fig.3.

From the results showed that yield of furfural increased at higher temperature and longer reaction time. The highest yield was obtained by optimization of hydrolysis reaction at 100°C for 4 hours. According to the following Arrhenius equation (Eq.3), as higher the reaction temperature, the rate of reaction increases. This is caused by the molecules movements become more rapid so that the rate of hydrolysis reaction increases nearly 2 times for every rising of 10°C (Groggins, 1958).

$$k = Ae^{-E/RT} \dots \dots \dots (3)$$

where k is the rate constant, A is the pre-exponential factor, E is the activation energy, and R is universal gas constant.

As the reaction time set longer, more furfural yield could be obtained due to longer contact between pentosan and the acid. However, too long reaction time would lead to formation of resin compound. As suggested by Andaka (2011), further heating of hydrolysis resulted in lower furfural yield. At higher temperature, the formed furfural degrades into acetic acid, methanol, and other organic compounds. The acetic

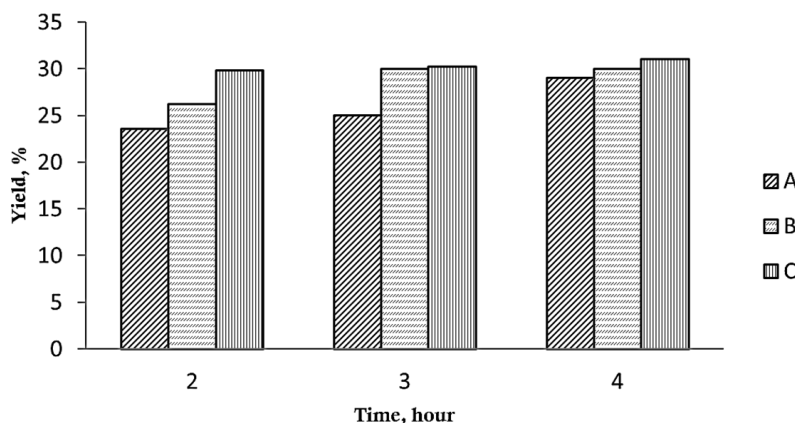

**Figure 3.** Yield of furfural from hydrolysis at reaction temperature of (A) 80°C, (B) 90°C, and (C) 100°C

acid is formed from hydrolysis reaction toward acetyl group on hemicellulose compound in the corncobs. This is consistent which was conveyed by Suharto and Susanto (2006) that further hydrolysis reaction degrades furfural into other compounds according to the following reactions:

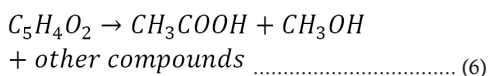
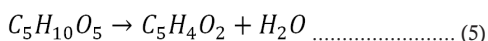
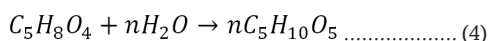

In order to understand the mechanism of furfural degradation, further experiments should be done at higher hydrolysis temperatures with longer reaction time.

## CONCLUSION

Furfural was synthesized from corncobs which contains pentosan up to 32%. Several reaction was done by varying temperature and reaction time in order to find the optimum condition. At higher reaction temperature and longer reaction time, rate of hydrolysis reaction was getting more rapid. The result showed the highest yield was 31% which was obtained from hydrolysis at 100°C for 4 hours. Qualitative identification using aniline-acetic anhydride showed that all samples contained furfural. Analysis using GC-MS confirmed the furfural compound and other impurities, such as toluene, 1,5-heptadien-3-yne, and benzaldehyde.

## REFERENCES

Ambalkar, V.U. and M.I. Talib, *Synthesis of Furfural from Lignocellulosic Biomass as Agricultural Resi-*

*dues: A Review.* The International Journal of Engineering and Science (IJES), 2012. 1(1): p. 30-36.

Andaka, G., *Hidrolisis Ampas Tebu Menjadi Furfural dengan Katalisator Asam Sulfat [Hydrolysis of Bagasse into Furfural using Sulfuric Acid Catalyst]*. Jurnal Teknologi, 2011. 4(2): p. 180-188.

Groggins, P.H., *Unit Process in Organic Synthesis*. Mc Graw-Hill Book Company, 1958(5th ed.): p. 775-777.

Hawleys, G.G., *The Condensed Chemical Dictionary*. 1971(Ed. 9).

Hidajati, N., *Pengolahan Tongkol Jagung sebagai Bahan Pembuatan Furfural [Processing of Corncobs as Feedstock for Producing Furfural]*. Jurnal Ilmu Dasar, 2006. 8: p. 45-53.

Iryani, D.A., et al., *Production of 5-hydroxymethyl Furfural from Sugarcane Bagasse under Hot Compressed Water*. Procedia Earth and Planetary Science, 2013. 6(0): p. 441-447.

Sangarunlert, W., P. Piumsomboon, and S. Ngamprasertsith, *Furfural Production by Acid Hydrolysis and Supercritical Carbon Dioxide Extraction from Rice husk*. Korean Journal of Chemical Engineering, 2007. 24(6): p. 936-941.

Setyadi, *Hidrolisis Pentosan Menjadi Furfural Dengan Katalisator Asam Sulfat Untuk Meningkatkan Kualitas Bahan Bakar Mesin Diesel [Hydrolysis of Pentosan into Furfural using Sulfuric Acid Catalyst for Enhancing Quality of Diesel Engines]*. Prosiding PPI-PDIPTN 2007: p. 159-165.

Shaukat Ali, F.A.C., Najia Irum, and Kiran Aftab, *Effect of Chemical Treatment on The Production of Furfural and Active Carbon from Rice Husks*. International Journal of Agriculture and Biology, 2002. 4(1).

Suharto, H.S., *Pengaruh Konsentrasi Katalis Terhadap Perolehan Furfural pada Hydrolysis Tongkol Jagung [Effect of Catalyst Concentration Toward The Furfural Yield on Hydrolysis of Corncobs]*. Prosiding Seminar Nasional IPTEK Solusi Kemandirian Bangsa, 2006.

Ullmann, *Ullmann's Encyclopedia of Industrial Chemistry*. 2000.