



DEVELOPMENT OF A LOW-COST ELECTRONIC WHEELCHAIR WITH OBSTACLE AVOIDANCE FEATURE

Edwin Romero Arboleda*, Mary Christine Tumaming Alegre, Kathleen Felix Idica

Department of Computer and Electronics Engineering, College of Engineering and Information Technology,
Cavite State University, Indang, Cavite, Philippines

Received 23 January 2015; received in revised form 02 December 2015; accepted 04 December 2015

Published online 30 December 2015

Abstract

A low-cost electronic wheelchair was designed and developed which can perform the similar functions and features as a commercially available wheelchair. It also provides obstacle avoidance capability as added value. The electronic wheelchair was realized by modification of a lightweight manual wheelchair. It uses two electric motors each of 320 W 24 V DC, 5-24 VDC 6 A H-bridge drivers, and a 12 V 17 Ah rechargeable lead acid battery. It is equipped with switches, joystick, infrared sensors and ultrasonic sensors. A Gizduino AtMega328 microcontroller is used to read and interpret commands. User's acceptance evaluation results show that the developed low-cost wheelchair is able to receive and interpret commands provided by the joystick, detect if a person is seated on it, navigate to avoid obstacles as well as to detect edge and stairs. Technical evaluation result shows that on a flat surface it could move at the speed of around 39.9 m/min without load and 32 m/min with 80 kg load. At 10 degrees inclined surface, the maximum weight limit is 30 kg with the speed of 12 m/min. At 20 degrees inclined surface, the maximum weight limit is 10 kg with the speed of 3 m/min. Regarding cost, it is just a fraction of a cost compared to the commercially available model. Therefore, the developed wheelchair offers an option for potential users who cannot afford to buy the commercially available one.

Keywords: electronic wheelchair; obstacle avoidance; edge detection; Gizduino AtMega328; microcontroller.

I. INTRODUCTION

Wheelchair was invented to serve as a primary means of mobility for persons with disability, those who are recuperating from illness and the elderly [1]. With the aid of wheelchairs they can move independently, can reintegrate into society as well as live productively [2][3].

The wheelchairs come in variations: manually operated wheelchairs that are propelled by the occupant by turning the large rear wheels or someone can push it through the handle in the back seat, and electrically powered wheelchairs that use motors for propulsion. Through decades of development and improvement electrically powered wheelchair now uses a mobile robotic technology [4][5][6] is equipped with some navigation systems that are a combination of joystick, infrared and ultrasonic sensors, camera, and machine vision for collision avoidance and

autonomous operation [7][8][9]. The most fundamental type of controller is the joystick mounted in the armrest. For others who are not capable of using a joystick, control systems using head gesture [10][11], speech [12][13], or tongue [14] may allow independent control of the wheelchair.

Operating a manual wheelchair usually needs another person to push it. Turning the wheels by the seated occupant is difficult, considering the user's condition. Thus, assistance from others is required. In hospitals, staffs are responsible for assisting the patients whose mobility depends on the wheelchair. Usually, a staff assists one patient but, with the electrically powered wheelchair, the staff would be able to assist more patients since the patients can control the wheelchair by themselves. Electrically powered wheelchairs provide more convenience than the manually operated wheelchairs, but not everyone can afford to buy one since it is expensive in the market today. For this reason, the authors have

*Corresponding Author. Tel: +63-9189597934
E-mail: edwin.r.arboleda@cvsu.edu.ph

decided to design and develop an electronic wheelchair that can reach the general performance of electrically powered wheelchairs available in the market today but with minimal cost.

This paper describes design and development of such a low-cost electric wheelchair and proposes obstacle avoidance feature as added value using appropriate sensors. User's acceptance test, technical performance, and cost analysis are presented through questionnaire and, experiment.

II. METHODOLOGY

The low-cost electronic wheelchair was designed to perform functions equivalent to the commercially available wheelchairs but with minimal cost. The commercially available wheelchair does not have sensors to serve as a safety switch and to detect and avoid obstacles thus, increase the probability of users getting into accidents. In line with this, the authors considered the addition of ultrasonic and infrared collision proximity sensors to ensure the safety of the users.

The microcontroller used is Gizduino AtMega328 [15] since it was found to fit the requirements of the design. The authors developed an electronic wheelchair by modifying a lightweight manual wheelchair. The following materials and components were installed on the wheelchair: two wiper motors, battery, battery voltage indicator, joystick, two ultrasonic sensors, one IR sensor, and the main circuit. Figure 1 shows the design of the electronic wheelchair. Each wheel is fixed to each motor using roller chain. Subsequently, the motors were connected to the drivers and the Gizduino. After the assembly, the result is a modified electronic wheelchair. Table 1 shows the specifications of the major electronic parts.

The navigational controller has five wires that are all connected to the Gizduino circuit. Likewise, two pins from each sensor were connected to the Gizduino circuit. The operation of the low-cost electronic wheelchair is shown in the block diagram in Figure 2.

The interface between the navigational controller and sensors that were interfaced to the Gizduino is shown in Figure 3. The system consists of a multi directional joystick that indicates forward, backward, right and left direction commands. Once the main switch of the electronic wheelchair is switched on, the battery will start to supply power to the main controller of the system that is the Gizduino ATmega328 with 40 mA output and the H-bridge Motor Driver with 50 mA output [16]. An infrared sensor placed on the right armrest that serves as a safety switch will detect whether a user is present or not. The presence of the user will trigger the infrared sensor [17] that will cause the joystick to be enabled.

Upon tilting the joystick forward, the 12 V wiper motor will rotate forward together with the rear drive wheels. However, if the ultrasonic sensor in front of the wheelchair detects that the wheelchair is heading towards the edge of the stairs with a distance of 0.127 meters, the electronic wheelchair will automatically stop. Upon tilting the joystick backward, the 12 V wiper motor will rotate backward together with the rear drive wheels.

However, if the ultrasonic sensor [18] in front of the wheelchair detects that the wheelchair is heading towards the edge of the stairs with a distance of 0.127 meters, the electronic wheelchair will automatically stop. Upon tilting the joystick backward, the 12 V wiper motor will rotate backward together with the rear drive wheels. However, if the ultrasonic sensor at the rear part of the wheelchair detects that the



Figure 1. The design of electronic wheelchair

Table 1.
Capacity electronic wheelchair specifications

Parts	Specifications
Microcontroller	1 pc., Gizduino Atmega328, 14 digital input/output pins, Six analog inputs, 16 MHz crystal oscillator
Motor	2 pcs, 320 Watt 24 VDC Permanent Magnet Motor
Battery	1 pc., 12 V, 17 AH rechargeable battery
H-Bridge	2 pcs, 5-24 VDC, 6 A E-gizmo H-Bridge Driver
Ultrasonic Sensor	2 pcs, Maximum detection distance = 4.5 meters
Infrared Proximity Collision Sensor	1 pc., Maximum detection distance = 25 cm

wheelchair is heading towards an obstacle with a distance of 0.9144 meters, the wheelchair will automatically stop

Upon tilting the joystick to the right, the main circuit will only allow the forward movement of the left and the right wheel to remain at rest, which makes the wheelchair move to the right. Upon tilting the joystick to the left, the main circuit will only allow the forward movement of the right wheel and the left wheel to remain at rest, which makes the wheelchair move to the left. The system will continue until such time that the main switch will be switched off, or the battery will be totally discharged.

III. RESULTS AND DISCUSSIONS

Figure 4 shows the developed wheelchair which consists of the following: wheelchair, joystick, two ultrasonic sensors, an infrared sensor, two wiper motors, battery, two h-bridge

motor drivers, and Gizduino ATmega328 microcontroller that controls the whole operation of the system. If the command is to move forward, the left and the right motors will revolve clockwise simultaneously. If the command is to move backward, the left and the right motors will revolve counterclockwise simultaneously

A platform was installed under the wheelchair to place the battery in the wheelchair. The battery voltage indicator was then fixed in front of the battery so that the user will be aware of the change in battery charge. The joystick was fixed to the right armrest of the wheelchair. The rocker switch that is responsible for turning the system on and off and the toggle switch that controls the speed of the electronic wheelchair to high (maximum speed) and low (minimum speed) were both attached to the joystick unit. The main circuit that consists of the Gizduino and two motor drivers and an ultrasonic sensor is placed at the rear of the electronic wheelchair. An antitip

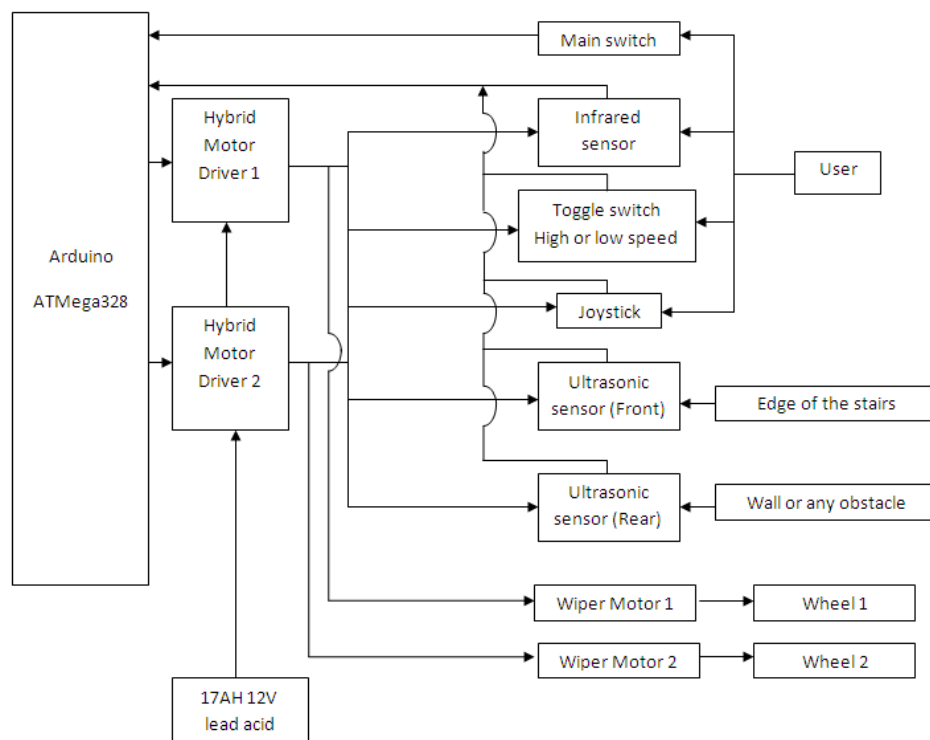

Figure 2. Block diagram of the designed low-cost electronic wheelchair

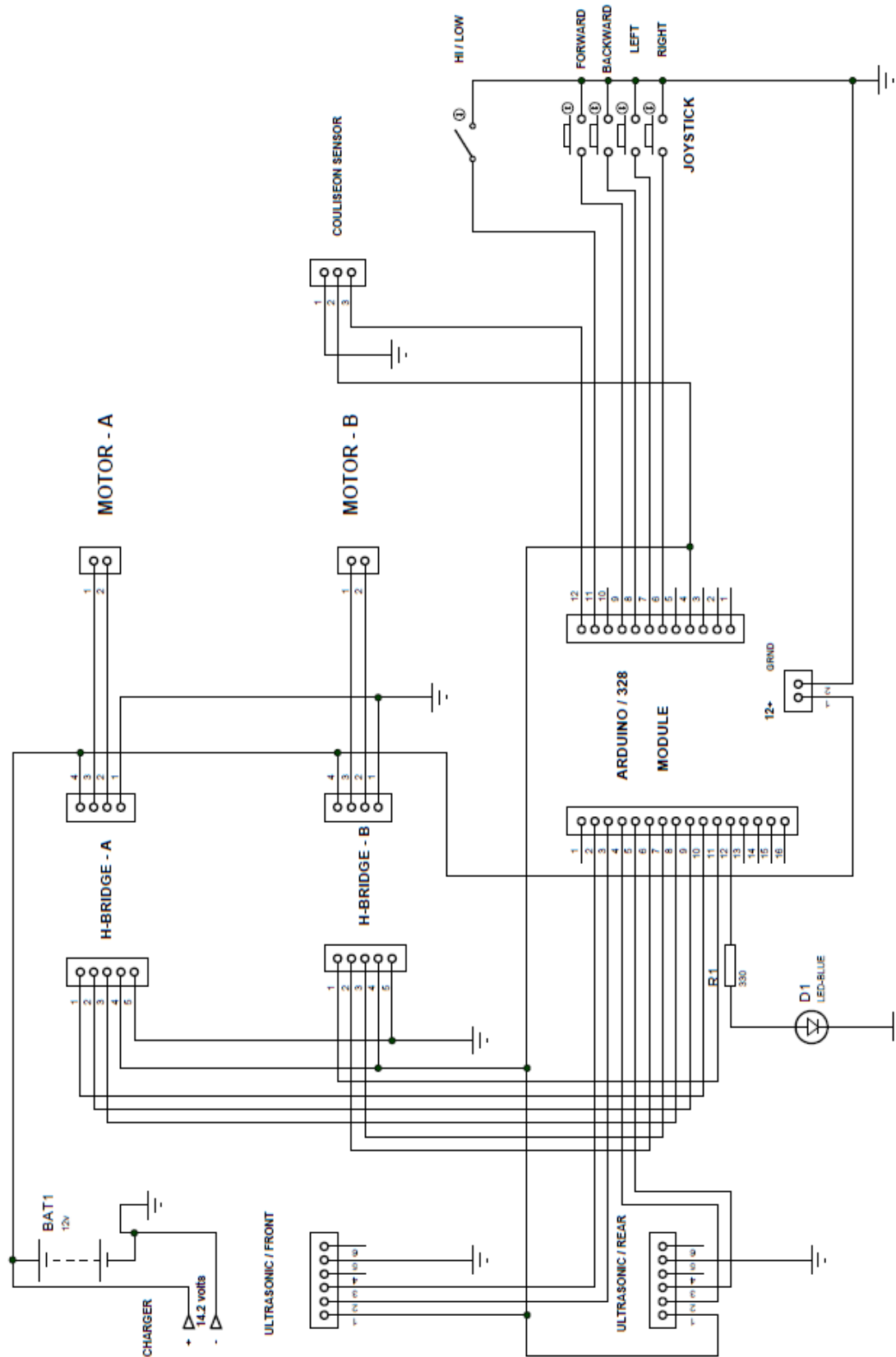

Figure 3. Schematic diagram of the circuit design

was also installed to the wheelchair so that it will still be usable if the battery is completely discharged. Two ultrasonic sensors and one IR sensor were installed on the wheelchair. One ultrasonic sensor is placed at the rear along with

the main circuit, tilted 73 degrees to detect obstacles at the rear. The other ultrasonic sensor is placed in front of the wheelchair, tilted 88.63 degrees to avoid falling from the stairs. The IR sensor is placed on the right armrest to serve as a

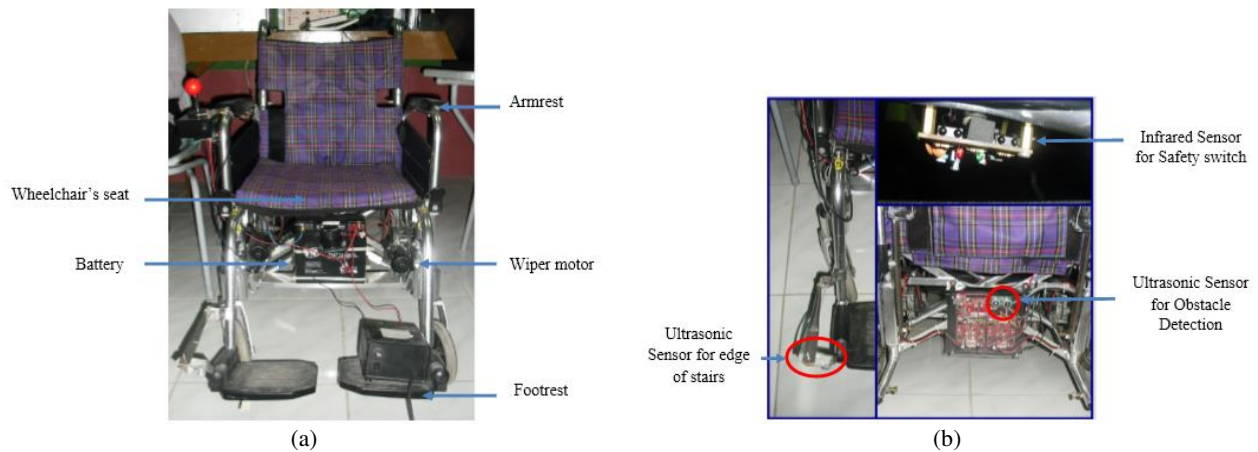

Figure 4. The developed electronic wheelchair; (a) front view; (b) back view

safety switch and ensure that the wheelchair will not move unless a seated occupant is present. A flowchart was made to show a succession of the electronic wheelchair operation.

The software used for the programming of the system was C Programming Language and was loaded to the Gizduino AtMega328. Figure 5 shows the program flowchart. To start the system operation, the rocket switch must be turned on. The system will then ask if the safety switch is on. If no, the system will end. If yes, the navigational joystick and sensors are enabled. Then, the system will ask if the joystick is maneuvered forward. If yes, the system will ask if the edge detecting sensor is on. If yes, the wheelchair will stop and ask if the safety switch is off. If yes, the wheelchair will turn off, and the joystick will be disabled. The program will then end. If the edge detector is off, the wheelchair will move forward. The system will then ask if the joystick is still maneuvered. If yes, the navigational joystick and sensors are enabled, and the process is repeated. If no, the wheelchair will stop and ask if the safety switch is off. If no, the navigational joystick and sensors are enabled, and the process is repeated. If yes, the wheelchair will turn off, and the joystick will be disabled. The program will then end.

If the joystick is not maneuvered forward, the system will ask if the joystick is maneuvered backward. If yes, the system will ask if the rear sensor is on. If yes, the wheelchair will stop and ask if the safety switch is off. If yes, the wheelchair will turn off, and the joystick will be disabled. The program will then end. If the rear sensor is off, the wheelchair will move backward. The system will then ask if the joystick is still maneuvered. If yes, the navigational joystick and sensors are enabled, and the process is repeated. If no, the wheelchair will stop and ask if the safety switch is off. If no, the navigational

joystick and sensors are enabled, and the process is repeated. If yes, the wheelchair will turn off, and the joystick will be disabled. The program will then end. If the joystick is not maneuvered backward, the system will ask if the joystick is maneuvered to the right. If yes, the wheelchair will move to the right. The system will then ask if the joystick is still maneuvered. If yes, the navigational joystick and sensors are enabled and the process is repeated. If no, the wheelchair will stop and ask if the safety switch is off. If no, the navigational joystick and sensors are enabled, and the process is repeated. If yes, the wheelchair will turn off, and the joystick will be disabled.

The program will then end. If the joystick is not maneuvered to the right, the system will ask if the joystick is maneuvered to the left. If yes, the wheelchair will move to the left. The system will then ask if the joystick is still maneuvered. If yes, the navigational joystick and sensors are enabled, and the process is repeated. If no, the wheelchair will stop and ask if the safety switch is off. If no, the navigational joystick and sensors are enabled, and the process is repeated. If yes, the wheelchair will turn off, and the joystick will be disabled. The program will then end. If the joystick is not maneuvered to the left, the wheelchair will stop and ask if the safety switch is off. If no, the navigational joystick and sensors are enabled, and the process is repeated. If yes, the wheelchair will turn off, and the joystick will be disabled. The program will then end. Evaluation of the developed wheelchair has been conducted through user's acceptance test, technical test, and cost analysis. Results of these evaluations are presented and discussed as follows.

The authors conducted user's acceptance evaluation for the electronic wheelchair using a survey questionnaire involving 30 persons with disability (PWD) participants categorized with

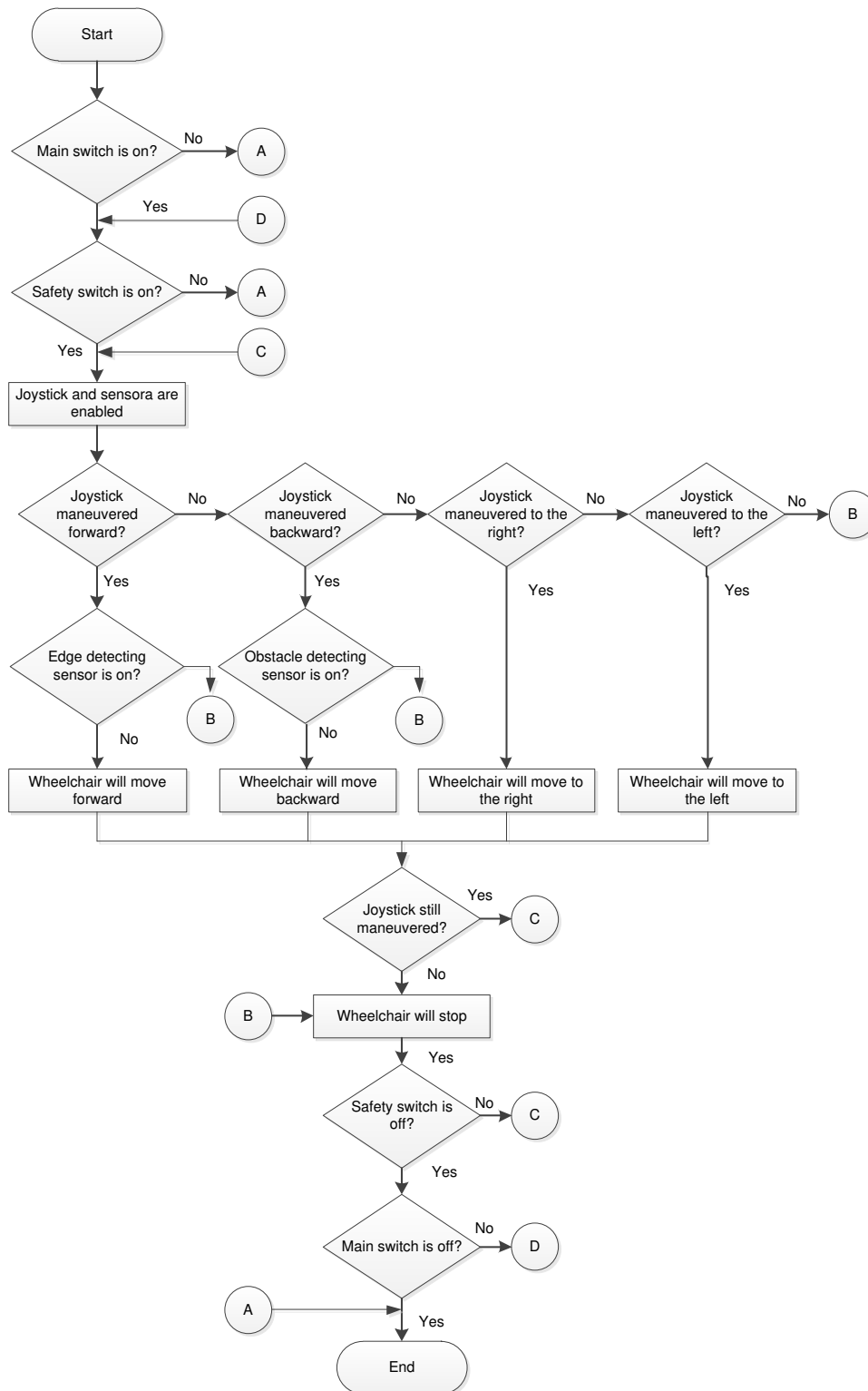

Figure 5. The system flowchart

their weights. The weight categories are divided into four, namely: weight category A (88 – 109.9 lbs.), B (110 – 131.9 lbs), C (132 – 153.9 lbs.) and D (154 – 175.9 lbs.). Seven questions were prepared to evaluate the low-cost electronic wheelchair: (1) the electronic wheelchair is easy to use, (2) it runs smoothly, (3) the joystick works properly (4) the sensor that serves as safety switch works properly, (5) the sensor in

the front part of the electronic wheelchair is effective for avoiding the stairs, (6) the rear sensor is effective for avoiding collisions, and (7) all the parts of the electronic wheelchair is functioning. Each question were rated using the following Likert scale: 4.5-5.0 = excellent; 3.5-4.49 = satisfactory; 2.5-3.49 = fair; 1.5-2.49 = needs improvement; 1-1.49 = poor.

Table 2.
Cost analysis result

Function	Model 1 (PhP 15 665.00)	Model 2 (PhP 65 250.00)	Model 3 (P 351 000.00)	Model 4 (P 450 000.00)
	Low-cost electronic wheelchair	Rear wheel drives wheelchair	Medalist power chair	Rear wheel drives power chair
Transports the user comfortably	√	√	√	√
Transports a user with a weight of at least 50 kg	√	√	√	√
Transports user to an inclined surface	√	√	√	√
Has sufficient speed	√	√	√	√
Has adjustable speed	√	√	√	√
Has good battery charge capacity	√	√	√	√
Detects and avoids obstacles	√	√	√	√
Detects and avoids stairs edge	√	√	√	√
Includes an alternative rear-wheel for manual operation	√	√	√	√
Includes safety switch that makes the wheelchair unusable when no seated occupant is present	√	√	√	√

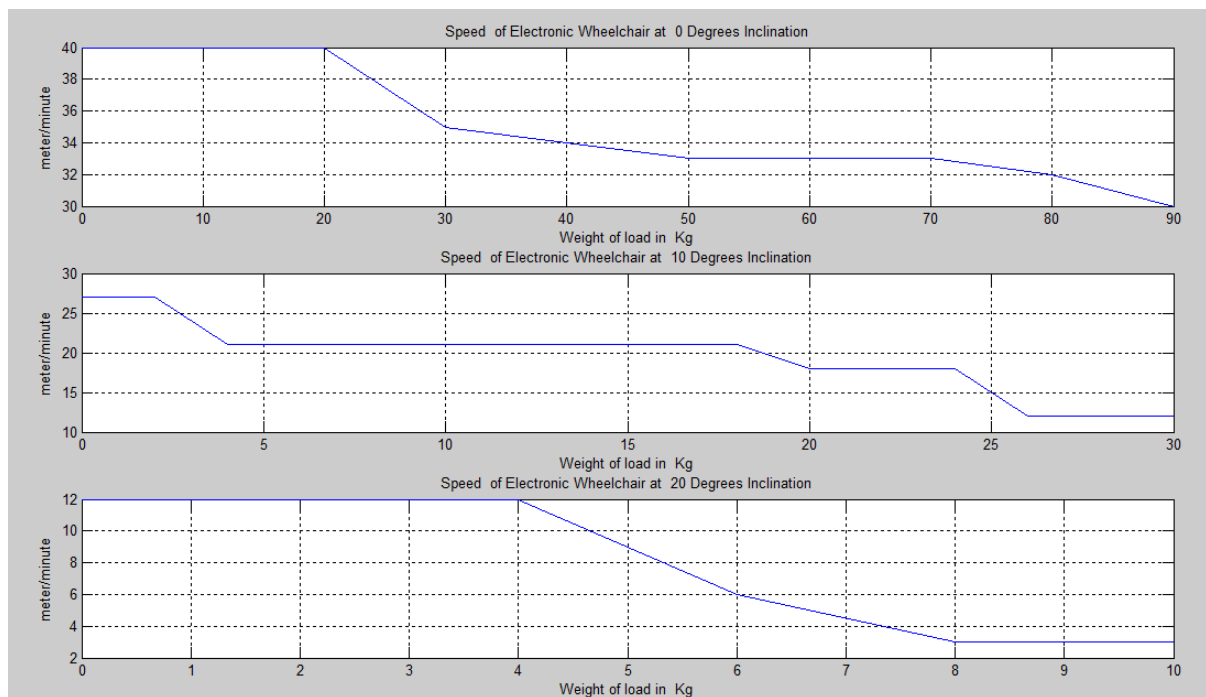

Figure 6. Speed of the electronic wheelchair as affected by floor inclination and weight of load

The overall mean for the performance of the low-cost electronic wheelchair is 4.5286. Therefore, the overall evaluation of the project is excellent. It is concluded that the low-cost electronic wheelchair is accepted by PWD users with regards to the weight category they belong to. Technical evaluation was conducted by measuring speed of the wheelchair as a function of load and inclination. Figure 6 shows the speed performance of the wheelchair. On a flat surface, it can move at the speed of around 39.9 m/min

without load and 32 m/min with 80 kg load. At 10 degree inclined surface, the maximum weight limit is 30 kg with the speed of 12 m/min. At 20 degree inclined surface, the maximum weight limit is 10 kg with the speed of 3 m/min.

The cost analysis was done by comparing the specifications of the low-cost electronic wheelchair with the three models of commercially available ones (rear wheel drive, medalist power, and rear wheel drive power). The cost analysis result is shown in Table 2.

IV. CONCLUSION

Based on the results gathered throughout the study, it can be concluded that a low-cost electronic wheelchair has been successfully developed. Through testing and evaluation with 30 PWD participants having different weights, the overall performance of the wheelchair is excellent. Its performance is equivalent to the commercially available electric wheelchair but is less in cost. Moreover, it has added values such as the infrared sensor as the safety switch and ultrasonic sensors for obstacle avoidance and edge (stairs) detection. Some recommendations for further improvement are: remote control may be added to the additional navigational controller so that navigation will be possible to users who cannot stretch their arms, and add buzzers for obstacle indication to alert the user.

ACKNOWLEDGEMENT

The authors gratefully acknowledge the training grant abroad provided to one of them by DOST-PCIEERD.

REFERENCES

- [1] R. A. Cooper, "Wheelchair research progress, perspectives, and transformation," *J. Rehabil. Res. Dev.*, vol. 49, no. 1, pp. 1 – 5, 2012.
- [2] V. de S. P. Costa *et al.*, "Social representations of the wheelchair for people with spinal cord injury," *Rev. Latino-Americana Enferm.*, vol. 18, no. 4, pp. 755–762, 2010.
- [3] H. Nunome *et al.*, "A kinematic study of the upper-limb motion of wheelchair basketball shooting in tetraplegic adults," *J. Rehabil. Res. Dev.*, vol. 39, no. 1, pp. 63 – 71, 2002.
- [4] B. Daveler *et al.*, "Participatory design and validation of mobility enhancement robotic wheelchair," *J. Rehabil. Res. Dev.*, vol. 52, no. 6, pp. 739–50, Jan. 2015.
- [5] B. Jenita Amali Rani and A. Umamakeswari, "Electroencephalogram-based brain controlled robotic wheelchair," *Indian J. Sci. Technol.*, vol. 8, no. S9, p. 188, May 2015.
- [6] E. Perez *et al.*, "Robotic wheelchair controlled through a vision-based interface," *Robotica*, vol. 30, no. 05, pp. 691–708, Aug. 2011.
- [7] Y. Ji *et al.*, "An intelligent wheelchair using situation awareness and obstacle detection," *Procedia - Soc. Behav. Sci.*, vol. 97, pp. 620–628, Nov. 2013.
- [8] M. R. M. Tomari *et al.*, "Development of smart wheelchair system for a user with severe motor impairment," *Procedia Eng.*, vol. 41, pp. 538–546, 2012.
- [9] R. A. M. Braga *et al.*, "IntellWheels: Modular development platform for intelligent wheelchairs," *J. Rehabil. Res. Dev.*, vol. 48, no. 9, p. 1061, Jan. 2011.
- [10] Z. Yi *et al.*, "Intelligent wheelchair system based on sEMG and head gesture," *J. China Univ. Posts Telecommun.*, vol. 22, no. 2, pp. 74 – 80, 95, 2015.
- [11] R. Tomari *et al.*, "Analysis of socially acceptable smart wheelchair navigation based on head cue information," *Procedia Comput. Sci.*, vol. 42, pp. 198 – 205, 2014.
- [12] A. Škraba *et al.*, "Speech-controlled cloud-based wheelchair platform for disabled persons," *Microprocess. Microsyst.*, vol. 39, pp. 819–828, 2015.
- [13] N. Peixoto *et al.*, "Voice controlled wheelchairs: fine control by humming," *Comput. Methods Programs Biomed.*, vol. 112, no. 1, pp. 156–65, Oct. 2013.
- [14] L. N. S. A. Struijk, "An inductive tongue computer interface for control of computers and assistive devices," *IEEE Trans. Biomed. Eng.*, vol. 53, no. 12 Pt 2, pp. 2594–7, Dec. 2006.
- [15] e-Gizmo Mechatronix Central, "gizDuino Version 5 w/ATmega328P ." [Online]. Available: <http://www.e-gizmo.com/KIT/gizduinov.html>. [Accessed: 05-Dec-2015].
- [16] e-Gizmo Mechatronix Central, "6.0A H-Bridge Motor Driver." [Online]. Available: <http://www.e-gizmo.com/KIT/hbd6.htm>. [Accessed: 05-Dec-2015].
- [17] e-Gizmo Mechatronix Central, "Infrared Proximity-Collision Sensor." [Online]. Available: <http://www.e-gizmo.com/KIT/Collision.HTM>. [Accessed: 05-Dec-2015].
- [18] e-Gizmo Mechatronix Central, "US-100 Ultrasonic Sonar." [Online]. Available: <http://www.e-gizmo.com/KIT/sonar.htm>. [Accessed: 05-Dec-2015].