

A simple monitoring network system of Wireless Sensor Network

Shengjun Su^a, Shuozhong Wang^b

^aCollege of Optical-Electrical and Computer Engineering, University of Shanghai for Science and Technology, ^bSchool of communication & information engineering, Shanghai University
No. 516, Jungong Road, Shanghai, China
e-mail: sushengjun@sina.com

Abstract

A SSNS (simple sensor network sniffer) is used to analyze and evaluate the Wireless Sensor Networks (WSN) effectively. SSNS is designed to monitor IEEE 802.15.4 protocol frame, which based on the Ethernet. Unlike the existed monitoring system, our design is much simpler and needs less resource. It is analyzed in this paper that the monitor network framework, time synchronization, and analysis program design. The results show that SSNS works stably, and can real-time display the frame monitored and reflect the dynamic change of WSN.

Keywords: WSN, protocol analysis, simple sensor network sniffer (SSNS), TinyOS

1. Introduction

Wireless Sensor Networks (WSN) are widely applied in military and national defense, environment monitoring, modern agriculture and other fields, and it has become an important part of the internet. The WSN scale is becoming larger and larger and the study method of WSN is in variety. WSN is similar to traditional wireless networks, but the difference is also significant. Work environment of WSN is often harsh: nodes are usually battery-powered and the energy is limited; the network topology is often unstable; network is vulnerable to be interfered by signal (WI-FI, Bluetooth) in the same frequency band. Considering the effectively monitoring on WSN, study on monitoring system will make great sense to the deployment of nodes and network test.

Currently, there are mainly three methods in analyzing and studying WSN: theoretical analysis, computer simulation and real-time monitoring. Theoretical analysis and simulation are less dependent on hardware platform, but many shortcomings exist. For theoretical analysis, the model is easier to build, but the algorithm is complex. It is also difficult to reflect the WSN fully, and the simplified algorithm cannot be satisfactory. Computer simulation can only reflect certain aspect of WSN. It cannot reflect the complexity and dynamic change of WSN. By establish the monitoring system can reflect the current state of the network. SSNS make us easier to study the communication protocol, topology, in-band interference, and energy consumption.

2. Related Work

Some foreign universities and research institutions start early on monitoring system platform design. Many well-known platforms are developed, such as Ohio State University's Kansei platform, Harvard University's Motelab platform. But those platforms focus on different aspects of WSN. Chinese Academy of Sciences and Hong Kong University of Science and Technology also do some research on WSN.

There are two design modes for the monitoring system: active and passive mode. For active monitoring system, monitoring module embeds in Sniffer node [1], and it has many defects, occupying the limited resource such as CPU, memory, consuming extra energy, occupying the signal bandwidth, also be conflict with the monitored network. The results cannot truly reflect the network state. For passive monitoring system, the monitoring system is set up beside the monitored system and it does not communicate with the monitored network. Sniffer nodes can form network through wire or wireless mode [2]: wireless mode occupies the limited

bandwidth and interferes with the monitored system, but wired mode affects little to the monitored system. In this paper, SSNS uses wired mode to establish the monitoring network.

3. System Structure

SSNS consists of three components: sensor nodes, Serial Ethernet module, and PC, as shown in Figure 1. Single sniffer node can only monitor the frame within one hop distance, and cannot reflect the entire network state. So establishing a monitoring network can help us study the WSN state more comprehensively [3]. Sniffer nodes arranged in the WSN join the network through Serial to Ethernet module. The Serial to Ethernet module and PC connect to the local area network (LAN) through cable. All Serial to Ethernet modules and PC are distributed a unique IP, guaranteeing that all IP addresses are in the same network segment. Sniffer nodes send the frame monitored to the PC through the LAN, and analysis program can analyze the frame then. Sniffer nodes receive the frame passively and they do not interfere with the WSN, so SSNS can truly reflect the WSN state.

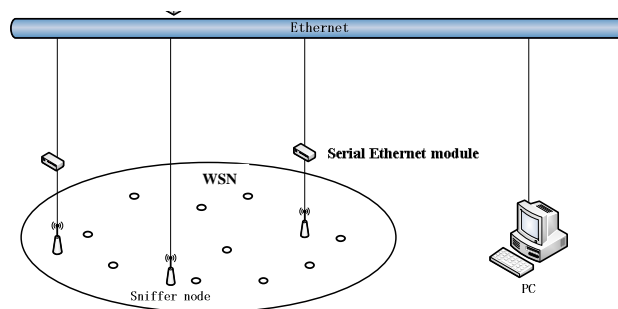

Figure 1. Notation used for SSNS

4. System Implementation

4.1. Sniffer node

CC2430 chip provided by TI is chosen as sniffer node, which supports IEEE 802.15.4 protocol, and TinyOS is used as the software platform, which designs specifically for WSN[4]. TinyOS bases on components and via interface to connect the components. Appropriate components and interfaces are chosen for programming, which increase the flexibility and quicken the development cycle.

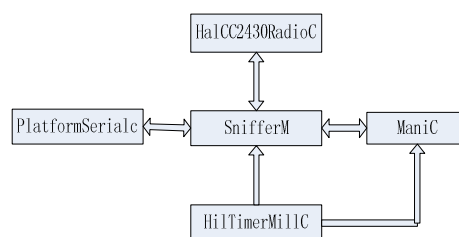

Figure 2. Sniffer node diagram

Sniffer nodes only need to receive the frame, so protocol stack is not necessary to use. Software of sniffer node consists of RF transceiver component, serial port component, and timer component, as shown in Figure 2. RF transceiver component is responsible for receiving the frame in the WSN. Serial port component is to receive the command from PC and send the frames to PC. Timer component is used to timestamp the frame in microsecond.

4.2. Serial Ethernet module

A ZNE-100TL module is used as the Serial Ethernet module, as shown in Figure 3. The module offers four operating modes: TCP Server mode, TCP Client mode, Real COM mode, UDP mode. Because the traffic is not too large, and in order to obtain the greatest possible speed, the UDP mode is used, which is connectionless-oriented. This can ensure transceiver works in real-time and reduce unnecessary delay. A second development is made in the basis of the module.

When the analysis program run, AT commands will be send to configure the parameters of each Serial Ethernet module: operating mode, IP address, port number. After configuring the parameters, analysis program on PC can communicate with each Sniffer node.

4.3. Analysis program

Analysis program on PC consists of initialization module, monitoring and processing module, and display module.

- (1) Initialization: *When* Analysis program starts, initialization will be conducted. It mainly does 3 aspects of work. First, XML parse file will be loaded into memory to parse the frame. IEEE 802.15.4 only defines the Physical layer and MAC layer, and the upper layers varies with various protocol. So in order to analyze different frames, XML parse file will be used to parse the frame.

After loading the XML parse file, initialization will query all Serial Ethernet modules, then configure UDP mode, IP address, and port number for the module.

Sniffer nodes follow their own clock. Sniffer nodes start at different time, so it is need to synchronize the time. PTP time synchronization is used to solve the problem, but it is too complicated [5]. For some smaller network, it needn't this. In SSNS, after configuring the Serial Ethernet module, analysis program can communicate with the Sniffer node. Analysis program send a broadcast signal to start SSNS. After receiving the broadcast signal, Sniffer nodes send back an acknowledgement frame to PC. Analysis program will normalization the time of Sniffer nodes based on the time contained in the acknowledgement frame.

- (2) Monitoring and Processing module: After completing the initialization, a monitoring thread and a processing thread will start. Monitoring thread is used for receiving the frame, and processing thread will parse the frame according to the XML file. Processing thread filters out the duplicate frame received from different Sniffer nodes through comparing the normalization receiving time. If frames are received at the same time, then compare the destination address and source address. Processing thread and monitoring thread synchronize each other through sharing memory. Monitoring thread shall block if the buffer is full, and processing thread shall block if the buffer is empty. Each time the frame in the buffer is processed, and then the Monitoring thread will be aroused. When frames are put into the buffer, then the Processing thread will be aroused. As shown in Figure 4.
- (3) Display module: Display module is mainly for convenience of visual analysis and debugging, and the results show in graphics. The main tasks include real-time display the frame, dynamic display the topology.

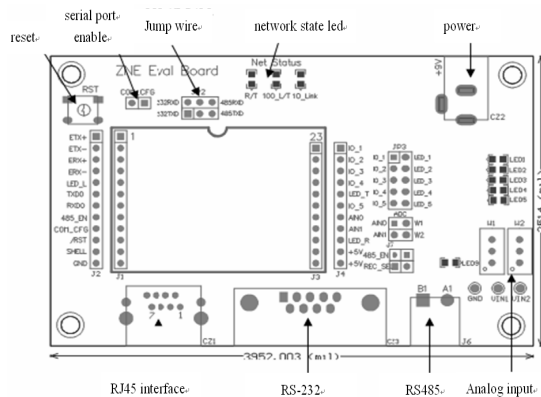

Figure 3. ZNE-100TL circuit diagram

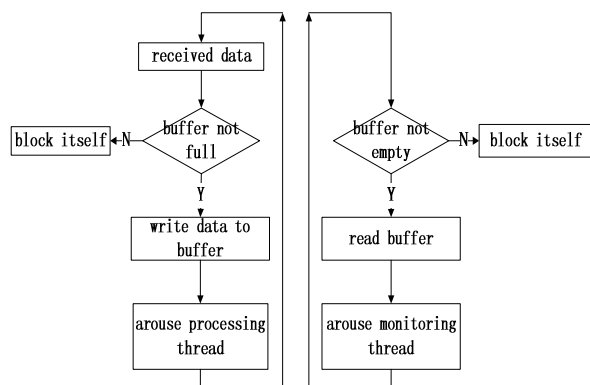

Figure 4. Monitoring and processing flow chart

5. Experiment Results

An experiment for WSN of 20 nodes with 10 meters spacing is established, which three sniffer nodes are inside and each connects to Ethernet through serial Ethernet module. CTP protocol and tree topology are used to organize the network. Terminal nodes send the light value to the sink node periodically, and the beacon frame is sent to maintain the network. Sniffer nodes monitor all these frames and send them to analysis program. The real time sniffer data, flow rate curve and node number curve are shown in Fig. 5.

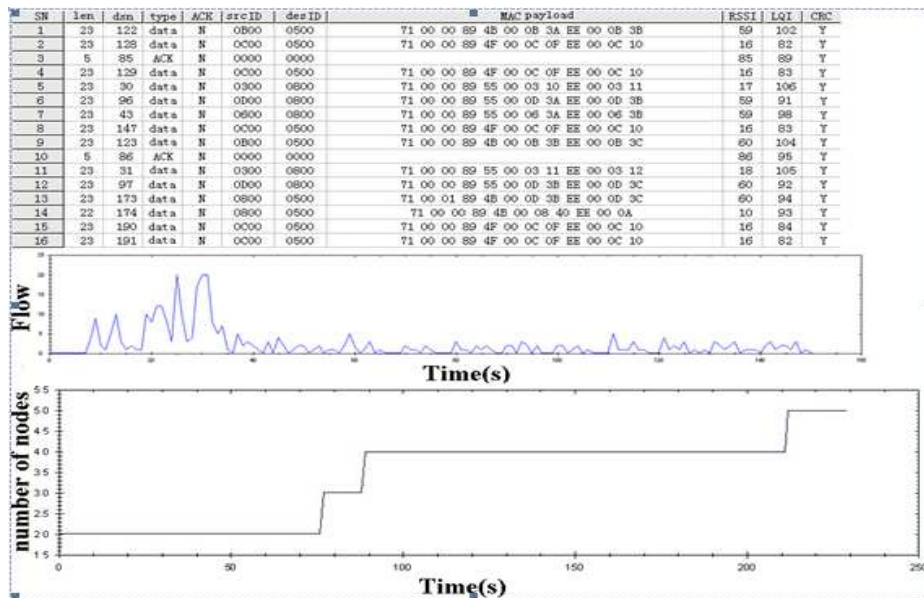

Figure 5. Monitoring results

6. Conclusion

A SSNS is used to overcome the one-sidedness of a single monitor node, monitor the whole WSN effectively, and display the network topology dynamically. A monitoring system is preliminary built, and future work will focus on the study of network stability, network latency, node energy consumption and so on.

References

- [1] Jiao Nan, Long Yin, Wang Xiao, Fengren Jian. A Testing System for Actual Wireless Sensor Networks. *Measurement & Control Techniques*, 2010; 29(5): 14-18.
- [2] Liangjin Lu, Xianghua Xu, Tong Chao. Research and Implementation of Wireless Sensor Network Protocol Analyzer. *Chinese Journal of Sensor And Actuators*, 2009; 22(12): 1828-1833.
- [3] Yu Yang, Peng Xia, Liang Huang, Quan Zhou, Yongjun Xu, Xiaowei Li. SNAMP: A Multi-sniffer and Multi-view Visualization Platform for Wireless Sensor Networks. *in Proceedings of 1ST IEEE Conference on Industrial Electronics and Applications*. Singapore. 2006; 1-4.
- [4] Jianxin Wang, Pengwei Zhao, Weiping Wang. A component-based testbed for wireless sensor network. *Computer Engineering and Applications*, 2010; 46(31): 111-114.
- [5] Xin Kuang, Jianhua Shen. SNDS: A Distributed Monitoring and Protocol Analysis System for Wireless Sensor Network. *in Proceedings of 2rd IEEE Conference on Networks Security, Wireless Communications and Trusted Computing*. Wuhan. 2010; 422-425 .