The Influence of Satisfaction toward Loyalty of Adolescent Consumers Mujigae Resto in Bogor City

Fidaa Nafiisah^{1*)}, Moh Djemdjem Djamaludin²

^{1,2} Department of Family and Consumer Sciences, Faculty of Human Ecology, IPB University,
Bogor 16680, West Java, Indonesia

*) Corresponding author: fidaanafiisah@gmail.com

Abstract

As the global popularity of South Korean culture called Korean wave is hitting around the world, Korean food has been drawing people's attention, and Korean restaurants have been developing in recent years. One of them is offered by a restaurant franchise called Mujigae Resto which can be found in many areas of Indonesia including Bogor City. This study aims to analyze the influence of satisfaction toward loyalty of consumers of Mujigae Resto in Bogor City. This study was a cross-sectional study design which used an online survey method. As many as 150 adolescents have participated in this survey. The sample criteria were individuals aged 16-18 years, residing in Bogor City, and had bought foods in Mujigae Resto at least two times in the last six months. The analysis included a descriptive analysis, Spearman correlation test, and hypothesis test with the Structural Equation Modeling (SEM) using the Analysis of Moment Structures (AMOS) program. The results showed that consumer adolescents in this study, generally, had satisfaction at a moderate level and loyalty at a low level. Consumer satisfaction significantly affected consumer loyalty on Mujigae Resto.

Keywords: adolescent, loyalty, Mujigae Resto, satisfaction, servqual

Abstrak

Seiring dengan popularitas budaya Korea Selatan yang disebut gelombang Korea (*Korean wave*) melanda seluruh dunia, makanan Korea telah menarik perhatian orang dan restoran Korea telah berkembang dalam beberapa tahun terakhir. Salah satunya ditawarkan oleh waralaba restoran bernama Mujigae Resto yang dapat ditemukan di banyak daerah di Indonesia termasuk Kota Bogor. Penelitian ini bertujuan menganalisis pengaruh kepuasan terhadap loyalitas konsumen remaja Mujigae Resto di Kota Bogor. Penelitian ini menggunakan desain *cross-sectional study* dan teknik survei menggunakan kuesioner *online*. Sebanyak 150 remaja menjadi responden penelitian ini. Kriteria responden adalah remaja berusia 16-18 tahun yang tinggal di Kota Bogor dan pernah makan di Mujigae Resto Botani Square Kota Bogor minimal dua kali dalam enam bulan terakhir. Analisis yang dilakukan meliputi uji deskriptif, uji korelasi Spearman, dan uji pengaruh dengan metode *structural equation modeling* (SEM) menggunakan program *Analysis of Moment Structures* (AMOS). Hasil penelitian menunjukkan bahwa kepuasan memiliki kategori sedang sedangkan loyalitas memiliki kategori rendah. Variabel kepuasan ini berpengaruh signifikan terhadap loyalitas pada Mujigae Resto.

Kata kunci: kepuasan, loyalitas, Mujigae Resto, remaja, servqual

Introduction

Consumer behavior is defined as behavior in finding, buying, using, evaluating, and spending products and services that are expected to satisfy needs (Schiffman & Kanuk, 1994). According to Kotler and Keller (2012), consumer buying behavior is influenced by cultural factors (culture, subcultures, and social classes), social (reference, family, roles, and status), personal (age, work economic, and lifestyle), and psychological factors (motivation, perception learning, and attitude). Cultural factors determine consumption patterns and patterns of decision-making (Ramya & Ali, 2016). Culture in Indonesia has adopted several cultures from other countries. Cultural, technological, economic and other information exchanges are made easier through globalization so that boundaries between countries are not the main thing. Globalization realized by the world community has a big impact on cultural exchange.

South Korean wave is a phenomenon that is happening in Indonesia. The spread of Korean culture due to the current of globalization is a natural thing that can happen. Korean wave made Indonesian adolescents start to learn Korean culture. The country which is famous for the development of its entertainment world, won the hearts of the people of Indonesia, especially among adolescents. The entry of South Korean culture in Indonesia began with Korean dramas (K-Drama) around the end of the 1990s. The influence of South Korean entertainment does not stop there; Korean fever phenomena such as K-Pop and variety shows have successfully followed the popularity of K-Drama. Other Korean cultures are starting to enter the Indonesian market such as Korean-style clothing, women's makeup and skincare, as well as the country's special foods which are starting to be loved especially by Indonesian adolescents.

The number of adolescents in Bogor City is the second-largest number of adolescents after the young adult population aged 20-24 years. According to the Statistics Indonesia of Bogor City (2017), the population of Bogor City aged 15-19 years is 95,663 people. Adolescence is divided into early adolescence (13 to 16 or 17 years) and late adolescence (16 or 17 years to 18 years) (Hurlock, 1990). One of the attitudes that are often shown by adolescents in groups is conformity with other group members (Izzaty, 2013). At the age of adolescence, individuals are more easily influenced by internet technology and social environment so that adolescents will be easily exposed to the Korean wave. Kaparang (2013) states that many Indonesian adolescents claim to be a fan of Korean celebrities.

A restaurant amid today's globally competitive market needs to have special characteristics to get consumers. Restaurants that provide Korean specialities have sprung up and formed competition in Indonesia, so companies need to win the hearts of consumers who love Korean food. Based on search results through the Google search engine, there are about 20 Korean restaurant outlets in Bogor. One of the most popular Korean restaurants among Indonesian consumers is Mujigae Resto. Mujigae is the first Korean restaurant to get an MUI Halal certificate in 2017. Mujigae Resto was first established in 2013 at Ciwalk, Bandung. To date, it has 19 branches, one of which is Mujigae Resto Botani Square in Bogor City. Mujigae Resto offers something different compared to other typical Korean restaurants, namely technological advancements. In addition to a diverse food menu, customers can also order food through tablets available at restaurant tables. The tablet can be used to view and order menus, take selfies with hanbok frames, make Korean music video requests, check bill orders, and have Korean television programs displayed on screens inside restaurants. These are interesting

experiences for Mujigae Resto customers. Also, the halal certificate that Mujigae Resto has already provides assurance that can make consumers feel safe to enjoy a meal. This thing offered by Mujigae Resto is believed to influence consumer satisfaction which indirectly influences consumer loyalty.

To survive in the market competition, it is not enough for a company to merely get consumers. Instead, a company needs to get loyal consumers or called customers. The advantage of having a customer is that the cost to retain consumers is far cheaper than finding new customers (Djati, 2005). Satisfaction is a pleasant fulfilment of needs, desires, goals, and so on (Oliver, 1997). It is the result of evaluating the difference between expectations and the actual performance of the product (Tse & Wilton, 1988). According to Haryono (2010), satisfied customers will be less price-sensitive, talk to others about the good of the company and its products, and remain loyal for a longer period.

Based on the explanation above, this study aims to 1) identify the characteristics of adolescents in Bogor City who have visited Mujigae Resto, 2) identify the satisfaction and loyalty of adolescents in Bogor City against Mujigae Resto, 3) analyze the relationship between the characteristics of adolescents with satisfaction and loyalty to Mujigae Resto, and 4) analyze the effect of satisfaction on adolescent consumer loyalty in Bogor City to Mujigae Resto.

Methods

Research Design

This study used a cross-sectional study design. The research data collection technique was a survey using an online questionnaire. This research was conducted in the city of Bogor in February to August 2019, which included data collection, data processing, and presentation of information, analysis and interpretation of data, and report writing.

Participants

The population of this research was adolescents aged 16-18 years who were living in Bogor City and have had eaten at Mujigae Resto at least twice in the last six months. The sampling method used in this study was voluntary sampling. The sample in this study amounted to 150 people.

Measures

Consumer satisfaction was measured using the SERVQUAL (service quality) instrument adapted and modified from the Cahyadi (2010) and Suherti (2016) questionnaires consisting of reliability, tangible, responsiveness, assurance, and empathy (Parasuraman, Zeithaml, & Berry, 1988). The Cronbach's Alpha value of this instrument was 0.973. There are five dimensions of service quality: reliability dimension consists (5 items), physical evidence (6 items), responsiveness (4 items), assurance (4 items), and empathy (5 items). Responses to these items were projected on a 4-point Likert scale (1=strongly disagree, 2=disagree, 3=agree, 4=strongly agree).

Loyalty was measured by consumers who make repeated purchases, consumers who advocate for others, consumers who advocate or defend companies and consumers who show immunity to bids from competitors. The questionnaire used to measure

consumer loyalty was the modification of the Soenjaya (2014), Bronto (2018), and Yusvari (2016) questionnaires. Responses to these items were projected on a 4-point Likert scale (1=strongly disagree, 2=disagree, 3=agree, 4=strongly agree). The Cronbach's Alpha value of this instrument was 0.687.

Data Collection Technique

Primary data collection was carried out using a questionnaire made on the Google Form. The online questionnaire was distributed to adolescents living in Bogor City via online platforms such as Line and Whatsapp.

Analysis

The obtained data went through the process of editing, coding, scoring, data entry, data cleaning, data analysis, and data interpretation. Data were processed and analyzed using Microsoft Excel 2016, SPSS 25.0, and AMOS 21.0 programs. Service quality evaluation using the SERVQUAL model includes calculating the difference between the values given by customers for each pair of questions relating to expectations and performance. SERVQUAL scores for each pair of statements for each customer were calculated based on the following formula (Zeithaml et al., 1990 in Tjiptono & Chandra, 2016):

$$\text{SERVQUAL score} = \text{Performance score} - \text{Expectation score}$$

The responses on the measurement of satisfaction and loyalty were summed up and produced a composite score. The composite score was then transformed into an index with the following formula:

$$\text{Index} = \frac{(\text{obtained score} - \text{minimum score})}{(\text{maximum score} - \text{minimum score})} \times 100$$

Index scores were then categorized into three groups (Khomsan, 2000), namely high, medium, and low. An index score of more than 80 is included in the high category, an index score between 60 to 80 in the medium category, and an index score of less than 60 in the low category.

Findings

Respondent Characteristics

The results showed that of 150 respondents, there were 24 male respondents and 126 female respondents aged 16-18 years. Respondents in this study were mostly at the age of 17 years (38%), which included in the category of late adolescence (Hurlock, 1990). The monthly allowance of respondents in this study was in the range of Rp100,000 to Rp3,000,000, with an average of Rp840,733. More than half of respondents (84.7%) were at the senior high school level. Respondents in this study mostly lived in parents' homes (84%) while the rest (16%) lived in boarding houses and relatives' houses. The main reason respondents ate at Mujigae Resto Botani Square was because of a friend's invitation (66%).

Satisfaction

Consumer satisfaction is the individual's perception of the performance of a product or service associated with the expectations of these consumers (Schiffman & Kanuk, 2004). Satisfaction in this study is a positive assessment felt by consumers Mujigae Resto after eating at Mujigae Resto. The level of satisfaction in this study was divided into three categories, namely low, medium and high, which can be seen in Table 1.

Table 1. Distribution of respondents by satisfaction category

Category	n	%
Low (<60)	13	8.7
Medium (60-80)	101	67.3
High (>80)	36	24.0
Total	150	100.0
Min-Max		34.72-100.00
Mean \pm SD		72.81 \pm 11.56

Satisfaction in the high category had a percentage of 24%. The highest percentage of satisfaction was in the medium category of 67.3%, while the index achievement in the low category had the lowest percentage of 8.7%. The average score of achievement index of respondents' satisfaction in this study was in the medium category of 72.81 with minimum and maximum values of 34.72 and 100.00, respectively. In addition to using questions on each dimension to find out customer satisfaction, satisfaction was also measured by asking customer satisfaction thoroughly to infer the level of satisfaction with Mujigae Resto services. The results showed that there were 144 (96.0%) respondents who expressed overall satisfaction with Mujigae services and the rest expressed dissatisfaction.

Gap Analysis of the SERVQUAL model that compares performance and expectations can be seen in Table 3. The average results per item of performance and expectations had a negative gap on all items. This result showed that the expectations held by customers for the Mujigae restaurant service performance were higher on all items. The results showed that SERVQUAL scores on all dimensions, namely physical evidence, reliability, responsiveness, assurance, and empathy, had negative values. This value was obtained from the difference between the performance score and expectations. The item with the smallest difference was item 11, with a gap score of 0.04. It states that the Mujigae Resto employee indicator provides a purchase bill following the price list, which has the closest performance to customer expectations. The item with the biggest difference was item 13 which states that Mujigae Resto employees are relatively fast in serving food ordered, the indicator had the most distant performance from the expectations of consumers with a gap value of 0.43. The dimensions of physical evidence and empathy had the greatest SERVQUAL score compared to other dimensions. This shows that the performance that is almost in line with consumer expectations lies in the dimensions of physical evidence and empathy, while responsiveness had the smallest SERVQUAL score, which means the performance of these dimensions is least in line with consumer expectations. The average total of the difference between performance and expectations showed that employee performance was almost in line with consumer expectations with a difference of -0.18.

Table 2. Gap Servqual Mujigae Resto Analysis

Item No	Mean per item		Gap	Dimension	Mean per dimension		Servqual score
	Performance	Expectation			Performance	Expectation	
1	3.27	3.49	-0.22				
2	3.33	3.48	-0.15				
3	3.33	3.41	-0.08	Physical evidence (item 1-6)	3.30	3.43	-0.13
4	3.28	3.37	-0.09				
5	3.27	3.43	-0.16				
6	3.37	3.43	-0.06				
7	2.98	3.36	-0.38				
8	3.37	3.46	-0.09				
9	3.21	3.37	-0.16	Reliability (item 7-11)	3.19	3.38	-0.19
10	3.08	3.33	-0.25				
11	3.34	3.38	-0.04	Responsiveness (item 12-15)	2.97	3.29	-0.32
12	2.81	3.15	-0.34				
13	2.91	3.34	-0.43				
14	3.14	3.34	-0.2				
15	3.03	3.36	-0.33				
16	3.19	3.36	-0.17	Assurance (item 16-19)	3.21	3.37	-0.16
17	3.07	3.34	-0.27				
18	3.30	3.40	-0.1				
19	3.30	3.39	-0.09				
20	3.15	3.33	-0.18	Empathy (item 20-24)	3.16	3.29	-0.13
21	3.23	3.35	-0.12				
22	3.19	3.37	-0.18				
23	3.07	3.28	-0.21				
24	3.19	3.32	-0.13				
Total	76.41	80.84	-4.43				
Average Total			-0.18				

Loyalty

Loyalty in this study refers to consumer loyalty to Mujigae Resto, which is characterized by a strong desire to eat at Mujigae Resto repeatedly now or in the future, encouraging others to eat at Mujigae Resto, giving a defence to Mujigae Resto against the negative assessment from others, and not affected by other Korean restaurants. The results showed that the majority of respondents in this study (72.7%) had a low level of loyalty to Mujigae Resto (Table 3).

Table 3. Distribution of respondents by loyalty category

Category	n	%
Low (<60)	109	72.7
Medium (60-80)	31	20.7
High (>80)	10	6.7
Total	150	100.0
Min-Max		0.00-100.00
Mean ± SD		55.67 ± 14.23

Relationship of Respondent Characteristics, Satisfaction, and Loyalty

The correlation test presented in Table 4 shows that almost all of the characteristics of respondents do not have a relationship with satisfaction and loyalty, except the level of education. Education level was negatively related to satisfaction ($r = -0.208$, $p < 0.01$). It means, the higher the level of education, the lower customer satisfaction is. Also, the results of the study also showed that there was a positive

relationship between satisfaction and loyalty. That is, when the perceived customer satisfaction increases, customer loyalty will also increase.

Table 4. The correlation test between respondent characteristics, satisfaction, and loyalty

Variable	Satisfaction	Loyalty
Gender	0.076	0.077
Age	-0.001	0.007
Education level	-0.208*	-0.082
Pocket money	0.102	0.052
Residence	0.081	-0.060
Satisfaction	1	0.540**
Loyalty	0.540**	1

Note: (*) significant at $p < 0.05$, (**) significant at $p < 0.01$

The Goodness of Fit Tests

Measurement Model

The goodness of fit tests for the measurement model was carried out by testing the validity and reliability. The reliability test in SEM is carried out through the calculation of Construct Reliability (CR), while the validity test is done through the calculation of Average Variance Extracted (AVE). The test results showed that satisfaction and loyalty had CR values of 0.95 and 0.71, respectively. Thus, the two latent variables had fulfilled the reliability requirements because they had a CR value of ≥ 0.7 . This shows that all indicators in the study produced consistent data if the measurements were repeated. The satisfaction and loyalty variables in this study sequentially had AVE values of 0.46 and 0.45. Validity test requires AVE calculation to have a minimum value of 0.5 but referring to Verhoeff, Franses, and Hoekstra (2002) the value of Average Variance Extracted 0.4 or close is enough to show good convergent per construct validity.

Overall Model

A model is said to be feasible if the model meets the specified criteria of goodness of fit. The test results showed that there was three model fit criteria in the marginal fit category. However, the overall model was acceptable because there were five criteria with a good fit. Test criteria whose results are not suitable can still be accepted in the marginal/good category because they are close to the range of Goodness-of-fit testing criteria (Santoso, 2014).

Table 5. The results of the overall model fit criteria

Goodness of fit criteria	Cut-off value	Result	Remark
CMIN/DF	≤ 2.00	1.107	good fit
Goodness of Fit Index (GFI)	≥ 0.90	0.879	marginal fit
Adjusted Goodness of Fit Index (AGFI)	≥ 0.90	0.843	marginal fit
Root Mean Square Error Approximation (RMSEA)	≤ 0.08	0.027	good fit
Root Mean Square Residual (RMR)	≤ 0.1	0.015	good fit
Comparative Fit Index (CFI)	≥ 0.90	0.985	good fit
Incremental Fit Index (IFI)	≥ 0.90	0.985	good fit
Normed Fit Index (NFI)	≥ 0.90	0.867	marginal fit

Contribution of Indicators to Latent Variables

Each indicator contributes differently to showing latent dimensions and variables. The relationship between the indicator and its latent variable can be seen from the loading factor value, as presented in Figure 1. The greater the loading factor of an indicator, the greater the contribution of the indicator in explaining the latent variable. The required loading factor is more than 0.5, so indicators that have a value below 0.5 need to be eliminated from the analysis model so that the loading factor meets the convergent validity test requirements. In the analysis of this model, two indicators were eliminated from the satisfaction variable, namely kp12 (“Employees invite customers to talk”) and kp17 (“The taste of the menu served does not change”).

The satisfaction variable consists of five dimensions, namely, physical evidence, reliability, responsiveness, assurance, and empathy. The biggest indicator describing the satisfaction variable was kp9 indicator that employees can be relied on in handling problems with a loading factor of 0.82. This means that the indicator is the most powerful indicator in explaining the satisfaction variable by 82%. On the contrary, the weakest indicator in explaining the variable was the kp2 indicator in the statement that the decoration is attractive with a loading factor of 0.50.

In Figure 1, it can be seen that the dimension of empathy has the greatest contribution in forming the satisfaction variable with a loading factor of 1.00. The dimensions of assurance, physical evidence, and reliability form satisfaction showed loading factors of 0.99, 0.95, and 0.94, respectively. The smallest dimension of contribution in forming variables was the responsiveness dimension with a loading factor value of 0.88.

Indicators that contribute to the loyalty variable after going through the elimination stage were repurchase, recommendations on others, and advocacy. The strongest indicator to explain the loyalty variable was ly2, which is a recommendation to others with a loading factor of 0.83. It means that ly2 explains the loyalty variable as many as 83%. The weakest indicator in explaining the loyalty variable was ly3, advocacy with a loading factor of 0.52. It explains that respondents who advocate (defend) Mujigae Resto when there are people who talk negatively about Mujigae Resto still do not explain the respondents' loyalty.

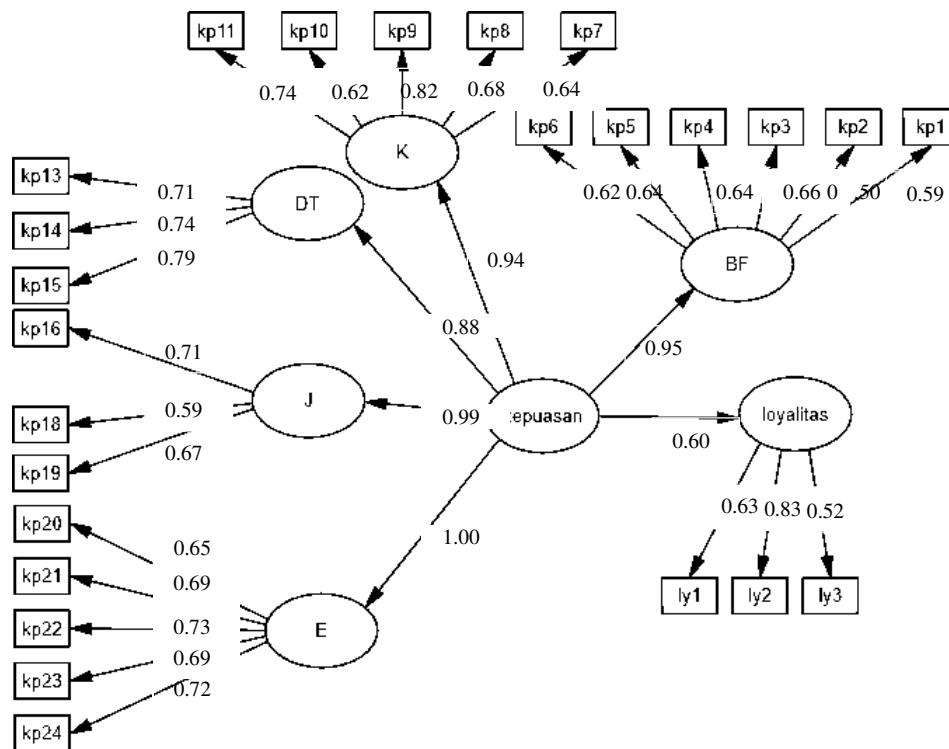

Figure 1. SEM model

Effect of Satisfaction on Loyalty

The effect of satisfaction on loyalty can be seen from the p-value and critical ratio values. The level of significance used in this study was 0.05. A variable is said to affect other variables if it has a critical ratio value of more than 1.96. A p-value of less than or equal to 0.05 and a critical ratio value of more than 1.96 indicates that a variable affects other variables.

The test results showed that satisfaction had a significant effect on loyalty because the value of the critical ratio was greater than 1.96 ($CR = 4.251, p < 0.05$). The path coefficient indicates the direction of the relationship. The path coefficient value in this study showed that satisfaction had a positive effect of 0.597 on loyalty. That is, the higher the customer satisfaction, the higher the customer loyalty.

Discussion

This study aims to analyze the effect of satisfaction on adolescent consumer loyalty to Mujigae Resto Botani Square in Bogor City. Mujigae Resto is one of the restaurants that provide typical food from South Korea and is a type of speciality restaurant. A speciality restaurant is a restaurant that specializes in providing special food from a country where the decoration and atmosphere displayed matches the characteristics of the country of origin of the food (Marsum, 1994). The majority of respondents in this study were female (84%) with a high school education level or equivalent (84.7%), living in a parent's house (84%), and having an average monthly allowance of Rp840,733. This research showed that more female respondents ate at Mujigae Resto than men. It can be caused by women who are more consumptive and are easily attracted to trying foreign cuisine than men (Suhartini, 2015).

The main reason respondents ate at Mujigae Resto was mostly because of an invitation from friends (66%). It is in line with the characteristics of adolescents who are easily influenced by the friendly environment. One important social change in adolescence is the increasing influence of peers (Krori, 2011). Besides, a person is usually easily influenced by the invitation of family/friends because they already trust each other (Pratita, Pratikto, & Sutrisno, 2018).

The relationship between age and pocket money with customer satisfaction and loyalty in this study was not found. This shows that high or low age and pocket money are not related to high or low satisfaction and loyalty. The gender and place of residence of the respondents also did not show a significant relationship with the high or low satisfaction and loyalty of respondents. This study found that education level had a negative relationship with satisfaction. It means, the higher the level of education, the lower customer satisfaction is felt. Siagian (2000) states that the higher the level of one's education, the greater the desires and expectations. Concerning customer satisfaction with products and/or services, high-quality services are needed to produce satisfaction because consumers with higher education tend to set high levels of expectation. It may cause their evaluation of the actual performance of a product and/or service, resulting in a low level of satisfaction.

Based on overall satisfaction answers, the majority of respondents (96%) were satisfied after eating at Mujigae Resto. On the other hand, consumer satisfaction based on three categories (high-medium-low) showed a moderate level of satisfaction (scores between 60 to 80) which can also be interpreted that Mujigae Resto Botani Square's food and service products are not disappointing. Further analysis with SERVQUAL analysis shows a more specific picture of aspects of customer satisfaction, not just on unidimensional evaluation (satisfied-dissatisfied). All SERVQUAL dimensions showed negative values, which means that there was a gap between consumer expectations and the actual performance perceived by respondents of Mujigae Resto Botani Square.

The results of the SERVQUAL model gap analysis indicated that respondents were most satisfied with the bill's compliance with the order list and the ease of finding the location of the restaurant. On the contrary, respondents felt the most dissatisfied with the speed of food serving and the suitability of food and beverage preparations. Respondents' satisfaction showed different results because the measurements were carried out in different ways. On the overall satisfaction question with unidimensional measurement, the majority of respondents tended to express themselves satisfied. However, when a more in-depth analysis was done through SERVQUAL, the level of satisfaction on each satisfaction indicator became visible because respondents were asked to evaluate their perceived expectations and actual performance.

The satisfaction variable consists of dimensions of physical evidence, reliability, responsiveness, assurance, and empathy. These five dimensions have shown a good contribution in explaining the satisfaction measurement variable by producing a loading factor above 0.5. The dimension with the largest contribution (loading factor) was empathy, while the responsiveness dimension indicated the lowest loading factor. This is in line with the research of Nurbuat, Katili, and Arina (2013), who found that the dimension of empathy has the greatest influence on customer satisfaction. The findings in this study are also in line with research by Ximenes (2017), who found that responsiveness has a loading factor value of 0.53, which is the weakest dimension in explaining satisfaction. However, although the loading factor of responsiveness in this study shows the lowest value compared to other dimensions, the figure has shown good

reliability and exceeds the minimum standard (loading factor=0.5) so that it still shows a good contribution in measuring satisfaction.

The loyalty variable consists of three indicators, namely repurchase, recommendations on others, and advocacy. The strongest indicator to explain loyalty variable was recommending to others with a loading factor value of 0.83. It is following the research of Darwin and Kunto (2014) who found that the highest value of loading factor is in the recommend friend indicator compared to the say positive things indicator and the purchase across product and service line. The weakest indicator to explain the loyalty variable in this study was advocacy. Advocacy (defence) had a lower loading factor value than the repurchase indicator. This finding is in line with the research of Jasfar (2002), who found that the most powerful indicators explain successive loyalty, namely repurchase, advocacy, then pay more. That is, repurchases are better at explaining loyalty than advocacy.

The results showed that the majority of respondents (72.7%) had a low level of loyalty, with an average loyalty score of 55.67 out of a score of 100. It means that respondents had a low possibility of repurchasing at Mujigae Resto, recommending Mujigae Resto to others, or making a defence (advocacy) if there are parties who give bad ratings about Mujigae Resto. Conversely, respondents have a high tendency to switch to other restaurants if they find a better restaurant than Mujigae Resto because the results of the study showed that only 37 respondents were immune to competitors' offers. This result supports Bronto's research (2018) which states that if the respondent finds a product that is better in terms of quality and price, then the respondent will be more likely to switch. Achievement of low loyalty from respondents in this study can be understood as a result of the low satisfaction of respondents on the service aspects (speed of serving food) and food quality (suitability of processed food and drinks). Similar results are found in other studies where service quality determines consumer loyalty (Widadi & Wadji, 2015).

According to Oliver (1999), customer satisfaction is an important factor that can make customers loyal. The results of this study found a significant positive relationship between satisfaction and loyalty. Respondent satisfaction in this study proved to have a significant effect on loyalty. This result supports the results of research by Henriawan (2015) who found that the higher the customer satisfaction, the higher the customer loyalty. The findings of this study also support previous studies which found that satisfaction variables significantly influence loyalty (Arwanda, Hartoyo, & Hartoyo, 2014; Pebriani, Sumarwan, & Simanjuntak, 2018; Aryani & Rosinta, 2010; Darwin & Kunto, 2014; Idham, 2013; Kurniawati, Suharyono, & Kusumawati, 2014; Larasati, 2013; Mustikarini, Retnaningsih, & Simanjuntak, 2014; Susanti, Sumarwan, Simanjuntak & Yusuf, 2019; Nidyatantri, Suryawardani, & Agung, 2016; Samudro, Sumarwan, Simanjuntak & Yusuf, 2019; Arief, Simanjuntak, Kirbrandoko, 2019).

In general, this study contributes to a more specific measurement of customer satisfaction by analyzing the gap between consumer expectations and the actual performance it perceives. The findings of this study can have implications for Mujigae Resto management to evaluate aspects of customer satisfaction as measured in this study. However, this study has limitations on the research methods conducted using an online questionnaire without being followed by in-depth interviews so that it is not possible to confirm responses to the research questionnaire to avoid response bias. Also, the scope of the research location in the Bogor City Mujigae Resto Botani Square branch is fairly narrow, and the number of respondents is limited so that repeated

investigations on this restaurant in other branches are needed to ensure the consistency of research findings. Loyalty measurements can also be increased by measuring the frequency of visits to Mujigae Resto to determine the frequency of repurchases. This study did not measure costs that are usually incurred in a single visit to see a comparison with the average monthly allowance of respondents as an illustration of purchasing power and the desire to pay consumers.

Conclusion and Recommendation

Conclusion

This study aims to analyze the effect of satisfaction on consumer loyalty Mujigae Resto Botani Square in Bogor City aged 16-18 years. The results found that respondents had a moderate level of satisfaction and a low level of loyalty. Furthermore, the results of the gap analysis of the SERVQUAL model specifically indicate differences in consumer expectations and actual performance perceived by consumers. The aspect that produces the highest customer satisfaction is the aspect of suitability of bills delivered by employees with a list of orders followed by ease of finding a location. Conversely, the aspect with the lowest consumer satisfaction is shown in the aspect of the speed of food serving by employees followed by the suitability of food and beverage preparations. The results of this gap analysis provide a better picture of consumer satisfaction with Mujigae Resto Botani Square. This research proves the hypothesis that satisfaction has a positive effect on loyalty. That is, the higher the customer satisfaction, the higher the customer loyalty.

Recommendation

Based on the findings in this study, several suggestions can be given. The level of adolescent consumer satisfaction towards Mujigae Resto Botani Square in this study is at a moderate level. It indicates that the management of Mujigae Resto may make efforts to improve customer satisfaction. Based on further findings, the management of Mujigae Resto needs to increase the speed of service by employees, especially in serving consumer orders. Considering that Mujigae Resto serves food that is a basic human need, the fast serving aspect is one of the important indicators that need to be considered by management. Also, as a speciality restaurant, Mujigae Resto can consider improving the quality of food and drinks to suit better the Korean food it represents. Providing facilities for advice and criticism from consumers or regular customer satisfaction surveys is also an important way to improve performance following consumer expectations to produce satisfied and loyal consumers.

Future studies are expected to complement the limitations of this study, among others by measuring the frequency of visits and the amount of average expenditure spent at Mujigae Resto. These variables can give an idea of the frequency of repurchases and the desire to pay. Future research should also examine other variables that can affect loyalty, such as price, trust, and commitment. Also, the subject of further research is expected to be broader and not limited to adolescents.

References

- Arief, A., Simanjuntak, M., & Kirbrandoko. (2019). Analysis of factors affecting the satisfaction and loyalty of the use of cargo services: a case study of PT. BEX. *Russian Journal of Agricultural and Socio-Economic*, 87(3), 276-283. <http://dx.doi.org/10.18551/rjoas.2019-03.32>
- Arwanda, N. O. D., Hartoyo, & Hartoyo, S. (2014). Kepuasan, citra, dan loyalitas pada lembaga pendidikan tinggi: Kasus di akademi xyz. *Jurnal Ilmu Keluarga dan Konsumen*, 7(2), 123-132. <https://doi.org/10.24156/jikk.2014.7.2.123>
- Aryani, D. & Rosinta, F. (2010). Pengaruh kualitas layanan terhadap kepuasan pelanggan dalam membentuk loyalitas pelanggan. *Jurnal Ilmu Administrasi dan Organisasi*, 17(2), 114-126.
- Bronto, S. I. (2018). *Pengaruh citra merek dan kepuasan terhadap loyalitas produk kosmetik Wardah pada mahasiswa Universitas Muhammadiyah Malang* (Undergraduate Thesis, IPB University, Bogor, Indonesia). Retrieved from <http://repository.ipb.ac.id:8080/handle/123456789/93098?show=full>.
- Cahyadi, F. (2010). *Pengaruh kualitas pelayanan terhadap kepuasan pelanggan pada restoran pizza hut cabang sun plaza* (Undergraduate Thesis, Universitas Sumatera Utara, Medan, Indonesia). Retrieved from <http://repository.usu.ac.id/handle/123456789/22121>
- Darwin, S., & Kunto, Y. S. (2014). Analisis pengaruh kualitas layanan terhadap loyalitas pelanggan dengan kepuasan dan kepercayaan pelanggan sebagai variabel intervening pada asuransi jiwa Manulife Indonesia-Surabaya. *Jurnal Manajemen Pemasaran Petra*, 2(1), 1-12.
- Djati, S. P. (2005). Pengaruh kinerja karyawan terhadap kepuasan, kepercayaan, dan kesetiaan pelanggan. *Jurnal Manajemen dan Kewirausahaan*, 7(1), 48-59. <https://doi.org/10.9744/jmk.7.1.pp.%2048-59>
- Haryono, T. (2010). Pentingnya menjaga dan meningkatkan hubungan baik dengan konsumen dalam masa krisis. *Jejak: Jurnal Ekonomi dan Kebijakan*, 3(1), 75-82. <https://doi.org/10.15294/jejak.v3i1.4666>.
- Henriawan, D. (2015). Pengaruh kualitas pelayanan dan kepuasan pelanggan terhadap loyalitas pelanggan. *Coopetition*, 6(2), 71-82.
- Hurlock, E. B. (1990). *Developmental Psychology: A Lifespan Approach*. Jakarta: Erlangga Gunarsa.
- Idham, F. B. (2013). Pengaruh dimensi kualitas layanan terhadap kepuasan nasabah dengan implikasi loyalitas pada PT. Bank Tabungan Pensiun Nasional, TBK cabang Kertajaya Surabaya. *Journal of Business and Banking*, 3(1), 93-108. <http://dx.doi.org/10.14414/jbb.v3i1.257>.
- Izzaty, R. E. (2013). *Perkembangan Peserta Didik*. Yogyakarta: UNY Press.
- Jasfar, F. (2002). Kualitas jasa dan hubungannya dengan loyalitas serta komitmen: Studi pada pelanggan salon kecantikan. *Jurnal Siasat Bisnis*, 7(1), 43-64.
- Kaparang, O. M. (2013). Analisa gaya hidup remaja dalam mengimitasi budaya pop Korea melalui televisi (studi pada siswa SMA Negeri 9, Manado). *Jurnal Acta Diurna*, 2(2), 1-15.
- Khomsan, A. (2000). Pengukuran tingkat pengetahuan gizi. Bogor: Fakultas Pertanian, Institut Pertanian Bogor
- Kotler, P., & Keller, K. L. (2009). *Manajemen Pemasaran* (13rd ed.). Jakarta: Erlangga

- Kotler, P., & Keller., K. L. (2012). *Marketing Management* (14th Global Ed). New Jersey: Prentice-Hall.
- Krori, S. D. (2011). Developmental psychology. *Homeopathic Journal*, IV(3).
- Kurniawati, D., Suharyono, & Kusumawati, A. (2014). Pengaruh citra merek dan kualitas produk terhadap kepuasan dan loyalitas pelanggan. *Jurnal Administrasi Bisnis*, 14(2), 1-9.
- Larasati, V. (2013). Analisis faktor-faktor yang mempengaruhi loyalitas pelanggan Coffee Toffee Jatim Expo di Surabaya. *Jurnal Gema Aktualita*, 2(2), 7-17.
- Marsum, W. A. (1994). *Restoran dan Segala Permasalahannya*. Yogyakarta: Andi Offset.
- Mustikarini, F., Retnaningsih, & Simanjuntak, M. (2014). Kepuasan dan loyalitas petani padi terhadap pestisida. *Jurnal Ilmu Keluarga dan Konsumen*, 7(2), 93-102. <https://doi.org/10.24156/jikk.2014.7.2.93>.
- Nidyatantri, N. M. M., Suryawardani, I. G. A. O., & Agung, D. G. (2016). Pengaruh kepuasan dan kepercayaan terhadap loyalitas konsumen kedelai jepang edamame pendekatan *Structural Equation Modeling*. *E-Jurnal Agribisnis dan Agrowisata*, 5(1).
- Nurbuat, E. M., Katili, P. B., & Arina, F. (2013). Analisis pengaruh kualitas pelayanan jasa terhadap kepuasan konsumen LP3G menggunakan *structural equation modeling*. *Jurnal Teknik Industri*, 1(1), 54-58.
- Oliver, R. L. (1997). *Satisfaction: A Behavioral Perspective on the Consumer*. New York: Irwin/McGraw-Hill.
- Parasuraman, A., Zeithaml V. A., & Berry, L. L. (1988). SERVQUAL: A multiple-item scale for measuring consumer perceptions of service quality. *Journal of Retailing*, 64(1), 12-40.
- Pebriani, W. V., Sumarwan, U., & Simanjuntak, M. (2018). The effect of lifestyle, perception, satisfaction, and preference on the online re-purchase intention. *Independent Journal of Management & Production*, 9(2), 545-561. <http://dx.doi.org/10.14807/ijmp.v9i2.690>
- Pratita, B. W. A., Pratikto, H., & Sutrisno. (2018). Analisis faktor-faktor yang memengaruhi keputusan pembelian pelanggan di Kober Bar Malang. *Jurnal Pendidikan*, 3(4), 497-503. <http://dx.doi.org/10.17977/jptpp.v3i4.10809>.
- Ramya, N., & Ali, S. A. M. (2016). Factors affecting consumer buying behavior. *International Journal of Applied Research*, 2(10), 76-80.
- Samudro, S., Sumarwan, U., Simanjuntak, M., & Eva, Z. Y. (2019). How commitment, satisfaction, and cost fluctuations influence customer loyalty. *Journal of Management and Marketing Review (JMMR)*, 4(2), 115-125. [http://dx.doi.org/10.35609/jmmr.2019.4.2\(3\)](http://dx.doi.org/10.35609/jmmr.2019.4.2(3))
- Santoso, S. (2014). *Konsep Dasar dan Aplikasi SEM dengan AMOS 22*. Jakarta: Elex Media Komputindo.
- Schiffman, L. G., & Kanuk, L. L. (2004). *Perilaku Konsumen* (7th ed.) (Z. Kasip, Trans.). Jakarta: Indeks.
- Setiadi, N. J. (2003). *Perilaku Konsumen: Perspektif Kontemporer Pada Motif, Tujuan, dan Keinginan Konsumen*. Jakarta: Prenada Media.
- Siagian, S. P. (2000). *Manajemen Sumber Daya Manusia*. Jakarta: Bumi Aksara.
- Soenjaya, C. (2014). *Pengaruh kualitas pelayanan, harga, dan citra perusahaan terhadap loyalitas pelanggan melalui kepuasan pelanggan pada Mc Donald's di*

- Surabaya (Undergraduate Thesis, Universitas Katolik Widya Mandala, Surabaya, Indonesia). Retrieved from <http://repository.wima.ac.id/1129/>.
- Suhartini. (2015). *Tingkat kepuasan konsumen terhadap kualitas produk dan pelayanan makanan khas Korea di Silla Restaurant Yogyakarta* (Undergraduate Thesis, Universitas Negeri Yogyakarta, Indonesia). Retrieved from <https://eprints.uny.ac.id/29367/>.
- Suherti. (2016). *Pengaruh kepuasan terhadap loyalitas konsumen laundry kiloan di Dramaga Bogor* (Undergraduate Thesis, IPB University, Bogor, Indonesia). Retrieved from <https://repository.ipb.ac.id/handle/123456789/84964>.
- Sumarwan, U. (2011). *Perilaku Konsumen: Teori dan Penerapannya dalam Pemasaran*. Jakarta: Ghalia Indonesia.
- Susanti, V., Sumarwan, U., Simanjuntak, M., & Yusuf, E. Z. (2019). Pengaruh perceived brand quality, perceived value dan switching cost terhadap customer satisfaction dan brand loyalty: studi pasar industri kimia di Indonesia. *MIX: Jurnal Ilmiah Manajemen*, 9(2), 282-297. <http://dx.doi.org/10.22441/mix.2019.v9i2.003>
- Tjiptono, F., & Chandra, G. (2016). *Service, Quality & Satisfaction*. Yogyakarta: Andi Offset.
- Tse, D. K., & Peter, C. W. (1988). Models of consumer satisfaction formation: an extension. *Journal of Marketing Research*, 25, 204-12. <http://dx.doi.org/10.2307/3172652>
- Umar, H. (2003). *Metode Riset Perilaku Konsumen Jasa*. Jakarta: Ghalia Indonesia.
- Verhoeff, P.C., Franses, P.H., & Hoekstra, J. C. (2002). The effect of relational constructs on customer referrals and number of service purchased from a multiservice provider. Does age of relationship matter?. *Journal of Academy of Marketing Science*, 3, 202-216. <http://dx.doi.org/10.1177/0092070302303002>.
- Widadi, R. H. S., & Wadhi, F. (2015). Faktor-faktor yang berpengaruh pada loyalitas pelanggan klinik saraf Rumah Sakit Jiwa Daerah Dr. R. M. Soedjarwadi. *Daya Saing*, 17(1), 28-37. <http://dx.doi.org/10.23917/dayasaing.v17i1.2270>.
- Ximenes, N. A. B. (2017). Pengaruh kualitas pelayanan terhadap kepuasan dan loyalitas mahasiswa pada Institute of Business (IOB) di Timor-Leste. *E-Jurnal Ekonomi dan Bisnis Universitas Udayana*, 6(8), 2917-2954. <http://dx.doi.org/10.24843/EEB.2017.v06.i08.p01>
- Yusvari, C. F. (2016). *Pengaruh kualitas pelayanan dan kepuasan konsumen terhadap loyalitas konsumen di Restoran Metduck Paragon Mall Semarang* (Undergraduate Thesis, Universitas Katolik Soegijapranata, Semarang, Indonesia). Retrieved from <http://repository.unika.ac.id/13391/>.