

DESIGN AND DEVELOPMENT OF STEEL BALL MOULD GRINDER FOR SAND GRINDING

Prof. Hetal B. Parmar

Mechanical Engg. Department

Dr. D.Y. Patil College of Engineering & Innovation, Varale, Talegaon, Pune

hetal.parmar@dypatilef.com

Patel Rajendrakumar Bachchulal

Mechanical Engg. Department

Dr. D.Y. Patil College of Engineering & Innovation, Varale, Talegaon, Pune

Dar Aadil Gani

Mechanical Engg. Department

Dr. D.Y. Patil College of Engineering & Innovation, Varale, Talegaon, Pune

Shaikh Zeeshan Zulfikar

Mechanical Engg. Department

Dr. D.Y. Patil College of Engineering & Innovation, Varale, Talegaon, Pune

Dadan Junaid Zahid

Mechanical Engg. Department

Dr. D.Y. Patil College of Engineering & Innovation, Varale, Talegaon, Pune

ABSTRACT—Review presented here deals with the design and development of steel ball grinder for sand grinding. The main objective of this paper was to reduce the cost of sand casting by recycling the already used mould sand. Steel ball sand grinder was used to grind and blend many moulding materials into fine powder. The procedure consists of removal of bentonite sand and dead clay from the mix. The reclaimed sand may find major uses in mould making in the foundry industry.

Keywords- Ball mill principle, Mould sand, Critical Speed, Reclaimed sand.

I. INTRODUCTION

According to the Institute of Indian Foundry-men reports (2011), there are about 4600 foundry units in India, of which, almost 80 % are small and medium scale foundries which are unable to bear the dumping cost associated with the waste sand. None of the existing reclamation methods are suitable or economical for foundries which requires reclamation capacity as low as 1000 kg per day. Also, the existing methods are associated with the generation with toxic gases (thermal reclamation) and Chemical Sludge. (Wet Mechanical)[1]. All in all, there is a need for cost-effective solution at the small or medium scale to address this issue.

The main objective of this paper is to study the reduction in the cost of sand casting by recycling the already used mould sand. Ball mill is a cylindrical device that used to

grind and blend raw materials and it rotates around a horizontal axis, partially filled with the material to be ground plus the grinding medium. When it is controlled by speed, the load nearest the wall of the cylinders will break and it quickly followed by other particles in the top curves

and form a sliding stream containing several layers of balls separated by material of varying thickness. Size reduction processes involve impacting a material with a ball, wall, blade, and hammer etc. will result in the single or multiple breakage events, which will produce a size distribution with mean particle size less than the supplied particle size [3].

II. EASE OF USE

Ball mill grinder is a cost-effective method of reclaiming foundry sand with no toxic gas generation as in thermal reclamation and no chemical sludge problem as encountered in wet mechanical treatment. It will certainly reduce the cost of foundry sand used and is simple in construction and easy to operate.

III. LITERATURE REVIEW

Dalquist et.al [8] studied newer techniques and products that draw more attention as they rise quickly from research to global scales, amplifying their environmental consequences. Joseph et. Al [2] looked at the economics of reuse and quality of the reusable sand,

currently, there is a number of small foundries with no sand reuse options. Danko et. Al [6] studied innovative reclamation technologies of used foundry sands such as mechanical-cryogenic reclamation and innovative thermal reclamation and found that Existing Reclamation Technologies are costly and require extensive equipments for reclamation. Dry Mechanical method is the most economic and by-products free method for sand reclamation technology. Maria et. Al [9] found that from an economic point of view, dry mechanical regeneration has proved to be the best solution but wet regeneration allows a better-quality product to be obtained. Still, as small foundries can't afford wet reclamation techniques. Hence dry mechanical method is a better option. Khan et. Al [1] found that it is possible to get usable sand after reclamation by attrition and sieving unit which is similar to our proposed ball mill principle. The method of sand testing like Total and Active Clay Content, Compressive Strength, And Grain Fineness Number (GFN). Ruthevaran et. Al [3] designed and fabricated the mini ball mill that can grind the solid state of the various type of materials into powder form. Magalinovic et. Al [5] determined the optimal ball diameter for the mill by theoretical and experimental techniques. Also, he determined the optimal ball charge. Kimura et. Al [7] put forth the concept of critical speed by discrete element and its empirical relation. They studied the effects of fin ball motion in the mill and relationship of the impact energy of balls on different parameters. Carvalho et. Al [4] determined that the batch grinding tests have been a very good tool to aid in understanding the effect of design and operating variables in ball milling, as well as in providing data for a couple of successful scale-up methods.

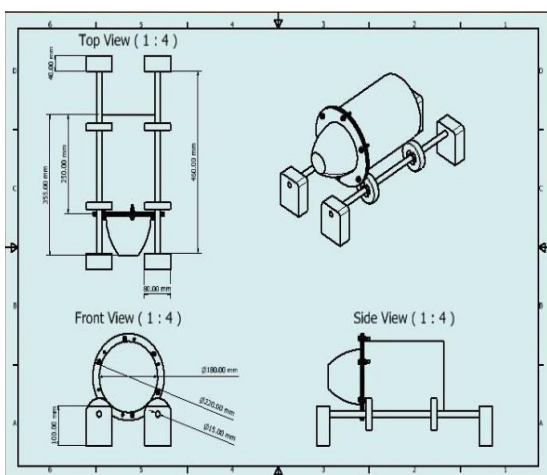

Fig.1. Schematic diagram of setup [3]

Fig.1 shows the setup used for fabrication of mini ball mill. It consists of a cylinder jar which is rotated by means of a belt drive pulley system. A 3-phase electric motor drives the whole system. The cylinder contains the charge of steel balls and used mould sand to be ground. The breaking of lumps takes place by means of the attrition force interactions between surfaces of cylinder and balls. [3]

Khan et. Al [1] modified the assembly and introduced two-stage attrition.

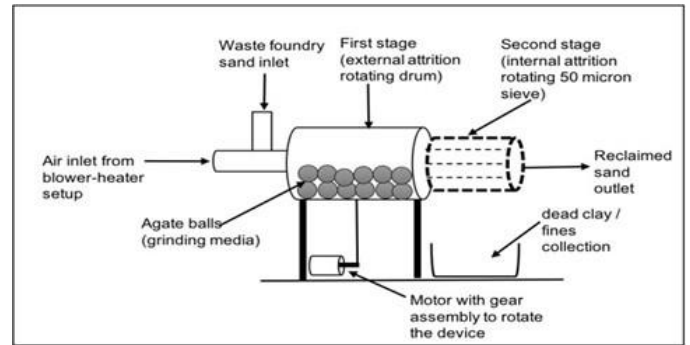

Fig. 2. Sieving and Attrition device [1]

As shown in Fig. 2, the first stage (external attrition) takes place in cylinder drum. It removes the dead coating of the binder from the sand surface. The second stage is internal attrition which takes place in a 50-micron sieve and separates out all the dead binder that gets weakened and removed in both stages. [1]

IV. EARLIER USED TECHNIQUES FOR SAND RECLAMATION

- Thermal reclamation: Thermal reclamation method is carried out in fluidization bed, where the air-gas mixture is burned to incinerate the used binding material from the sand basis [6].
- Dry mechanical reclamation: The reclamation treatment is based on the grinding of individual sand grains, to free the particles of binding agents and other compounds and on the recovery of fine particles by means of a de-dusting and filtering system [9].
- Wet mechanical reclamation: Wet mechanical reclamation method employs the use of chemicals for removing the bentonite from the sand surface [1]
- Cryogenic method; In mechanical cryogenic treatment method, the used sand mixture is treated at around at -70 degree Celsius, which in result contracting of the bentonite bonded on sand surface and thus is removed afterward [6].

CONCLUSION

- The literature discussed here displays the cost effective method for sand reclamation. It was found that sand ball grinder can effectively be used separate bentonite binders from mould sand. Also, this method is environmentally friendly as no toxic gases or chemical sludge is generated.

ACKNOWLEDGMENT

We are very thankful to all the teachers, students and friends who directly or indirectly helped us to complete this review paper. We express our gratitude to our Principal, HOD for their continuous guidance and moral support to help accomplishing this task.

REFERENCES

1. Mohd Moiz Khan, Mahendra Singh, Sanjay M, G.N Jadhav, S. Mandre, "**Reclamation of used green sand in small scale foundry**", *Journal of materials processing technology*, Vol. 255, pp 559-569 (2018)
2. Meera k. Joseph, Farai B. D.Oyombo, "**Moulding sand recycling and reuse in foundries**" *Procedia manufacturing*, 86-91 (2016)
3. Maria, Rutheravan. "**Design and fabrication of mini ball mill**". *Mechanical system design*. (2016)
4. Rodrigo M. de Carvalho, Luis M. Tavares "**Predicting the effect of operating and design variables on breakage rates using mechanical ball mill model**", *Minerals engineering*, 91-101 (2013)
5. Nedeljko Magdalinovic, Milan Trumic, Maja Trumic, L. Andric, "**The optimal ball diameter in a mill**", *Physicochemical problems of minerals engineering*, 329-339(2012)
6. Danko, R. "**Innovative development in sand reclamation technologies**", *METALURGIJA*, 93-96 (2011)
7. T. Kobayashi, Makio Kimura, M. Narumi, "**Design method of ball mill by discrete element method**", *Sumitomo kagaku*, vol2(2007)
8. Stephanie Dalquist, Timothy Gutowski, "**Life cycle analysis of conventional manufacturing techniques: sand casting**", *ASME International mechanical congress and exposition*, 1-11 (2003)
9. Maria Chiara Zanetti, Silvia Fiore, "**Foundry processes: The recovery of green moulding sand for core operations**", *Resources, conservation and recycling*, 243-254(2002)
10. Cleary, Paul W. "**Charge behaviour and power consumption in ball mill**", *International Journal of Mineral Processing*, 79-114(2001)