

## RESEARCH ARTICLE

## OPEN ACCESS

Manuscript received August 10, 2021; revised August 31, 2021; accepted September 1, 2021; date of publication October 15, 2021

Digital Object Identifier (DOI): <https://doi.org/10.35882/jeeemi.v3i3.4>

This work is an open-access article and licensed under a Creative Commons Attribution-ShareAlike 4.0 International License ([CC BY-SA 4.0](https://creativecommons.org/licenses/by-sa/4.0/))



# Design of an Electromyograph Equipped with Digital Neck Angle Elevation Gauge

A. Kamil Solihin<sup>1</sup>, E. Yulianto<sup>1</sup>, H. G. Ariswati<sup>1</sup>, and K. K. Mujeeb Rahman<sup>2</sup>

<sup>1</sup>Department of Electromedical Engineering Poltekkes Kemenkes, Surabaya 60245, Indonesia.

<sup>2</sup>Faculty of Engineering Ajman University, Ajman, U.A.E.

Corresponding author: Ahmad Kamil Solihin. Author (e-mail: [p27838117021@gmail.com](mailto:p27838117021@gmail.com)).

**ABSTRACT** The purpose of this study is to design a system that can measure the electromyography of neck muscles equipped with an elevation of a person's neck angle. Furthermore, the system can be used to assist health workers and medical rehabilitation doctors in diagnosing as well as providing treatment to patients with a bent head posture or forward head posture. The respondents were male students, with ages ranging between eighteen to twenty-two years, who do not have the habit of playing video games. The research concludes that the neck angle elevation gauge has an error rate of 0.957%. For the conditionings conducted on respondents, everybody experienced an increase in amplitude on the same frequency spectrum, which was as long as the increment of neck elevation angle. Meanwhile, a drastic increase occurred at the neck angle of 60°. Thus, it can be concluded that the developed module can measure the electromyography signal of neck muscles and the elevation of the neck angle. The forward position of the head affects the frequency spectrum of the neck muscles, whereas the position that increases the amplitude of the signal is when the head is bent downwards with the face is still facing forward. Further research is required to replace the neck angle elevation sensor with a more accurate one along with the development of electromyography signal processing for additional benefits.

**INDEX TERMS** Electromyography, MPU6050, Forward Head Posture.

## I. INTRODUCTION

In this pandemic era, the use of laptops and computers has increased along with work from home and online learning. Unfortunately, someone often ignores his posture when working in front of a computer or laptop. Someone who works in front of a computer tends to lean his head forward, causing a bent posture. Head tilted forward can cause health problems[1]. According to Kapandji, the neck and upper shoulder muscles will be burdened by 0.45 kg each head forward as much as 2.5 cm. The neck and upper back muscles need more stretch to support the head[2]. If the wrong sitting posture accumulates for a long time, it can cause a forward head posture (FHP)[3].

FHP allows a person to lose 30% of the vital capacity of his lungs[4]. Continuous stress on the muscles can cause muscle fatigue. According to a study conducted by Cooper et al. In 2008, they found that working at a computer continuously correlated with discomfort in students[5]. They suggested the implementation of a system to intervene in the

ergonomic position of students while sitting. The study of the correlation between head position and neck muscle concluded that it could affect neck muscles[6]. The same purpose of the study has been done by S. Kim et al. I[7].

Based on several studies, it can be concluded that it is important to establish a system that can measure the elevation of the neck angle and electrical activity in the neck muscles for medical personnel to diagnose and provide action for patients with FHP. This study conducted by Yeom et al. in 2014 created a system to measure head tilt. However, there is no muscle activity monitor yet. The purpose of this study is to join the monitoring of muscle electrical activity and neck elevation gauge to determine the relationship between electrical muscle activity and a person's sitting position while working in front of a laptop. Hopefully, this study can facilitate the diagnosis process for doctors to determine treatment for patients with a forward head posture, and further research can be developed to overcome the problem of forwarding head posture (FHP).

## II. MATERIALS AND METHODS

### A. EXPERIMENTAL SETUP

This study was conducted on three respondents who were sitting working in front of the computer. The distance between the respondent and the computer is 60 cm. Respondents are normal people without FHP disorders. The muscle tapped is the upper trapezius muscle. Respondents were treated with different neck angle elevations ( $0^\circ$ ,  $30^\circ$ ,  $60^\circ$ ) using an accelerometer sensor[8], then measuring their neck muscle signal leads using electromyography[9]. Data collection was carried out for 5 minutes on each neck elevation angle measurement, and 10 minutes beginning and 10 minutes last in 30 minutes contraction for  $30^\circ$  neck elevation angel.

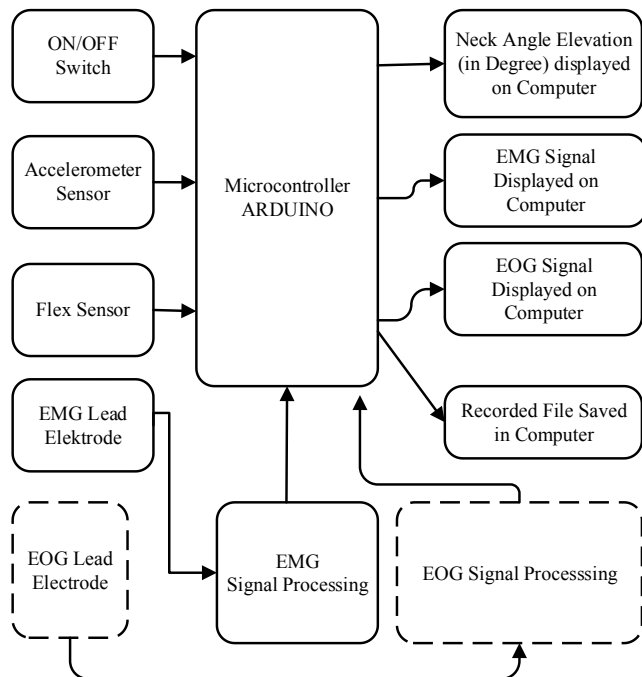

FIGURE 1. The diagram block of the module

### 1) MATERIALS AND TOOL

This study uses a series of electromyography to detect biosignals from neck activity[10]. The electrode used is Ag-ACL disposable electrode. The Electromyography block module circuit consists of an instrumentation amplifier circuit that uses an Op-Amp TL074 IC[11], a high pass filter circuit that uses a TL074 IC, a low pass filter circuit that uses a TL074 IC, and an adder circuit consisting of a summing amplifier circuit using IC TL074 and a voltage divider circuit, the accelerometer circuit uses the MPU6050 sensor as the neck angle elevation sensor[12], the Atmega328 microcontroller as the sensor data processor[13]. Oscilloscope with digital storage (TEXTRONIC, DPO2012, Taiwan) to retrieve test point data on analog circuits.

### 2) EXPERIMENT

In this study, the data taken were EMG signals from three respondents conditioned with different neck angle elevations ( $0^\circ$ ,  $30^\circ$ ,  $60^\circ$ ); they were conditioned to contract for 5 minutes. The signals were recorded. The second conditioning is one respondent watched the video on the laptop for 30 minutes on  $30^\circ$  neck angle elevation, the ten minutes of the beginning were recorded, and the ten minutes last too. After the signals are recorded and stored, they are compared to whether there is a change in the frequency of the data. The method used is Fast Fourier Transform (FFT)[14]. After processing the FFT on the two data, the data is presented in a table.

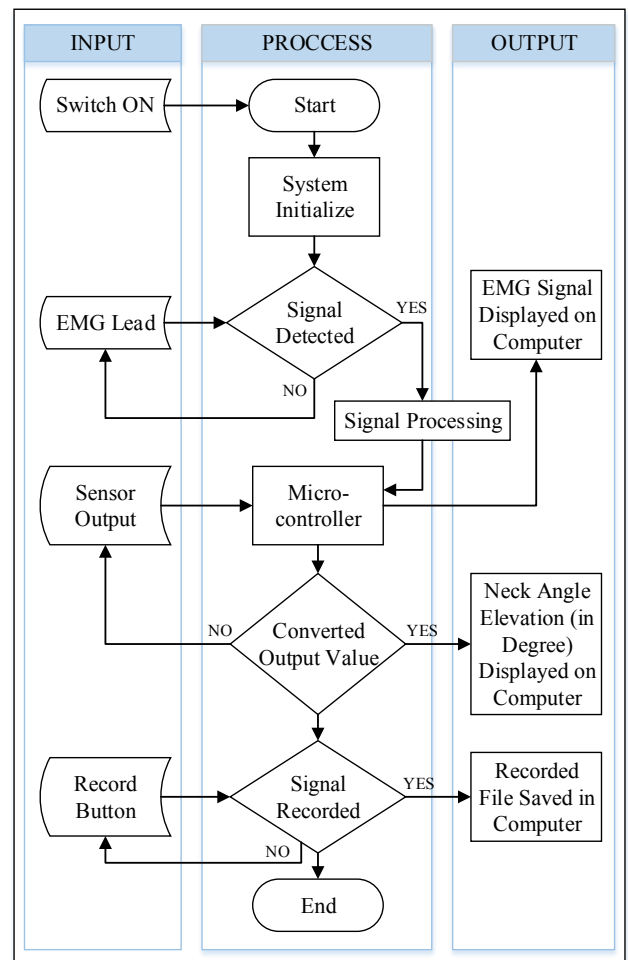

FIGURE 2. The Flowchart of the Arduino Program

### B. THE DIAGRAM BLOCK

In this research, the diagram block is shown in FIGURE 1. When the on switch is pressed, the tool initializes the accelerometer circuit block, and the sensor flex as the neck angle elevation sensor and the EMG[15] circuit block is active. The EMG circuit block detects biosignals from neck muscle activity, and the elevation sensor detects the

coordinate position of the head to determine the elevation of the neck angle.

The values of the head position readings and neck curvature are processed, the processed readings are displayed on the computer in degrees. Biosignals from neck muscle activity are processed in a microcontroller, which will be displayed on a computer to see the difference in signal shape between neck angle elevations of  $0^\circ$ ,  $30^\circ$ ,  $60^\circ$ .

### C. THE FLOWCHART

The Arduino program was built based on the flowchart as shown in [FIGURE 2](#). When the ON button is pressed, the module starts to initialize. The electromyography signal is tapped through the electrodes into the electromyography analog circuit. Through instrumentation and filters, the signal goes through Arduino as an ADC so that the signal can be displayed on a computer. Sensors are reading the zero point when the participants are in an upright position. The output of the sensor is displayed on a computer in degree. On the computer display saving option are available on a saving button.

When the process starts, the signal of electromyography is displayed and the output of the sensor too and when the Save button is pressed, the signal will be saved on the computer; the recording is complete.

### D. ANALOG CIRCUIT

#### 1) INSTRUMENTATION AMPLIFIER CIRCUIT

The instrument circuit as shown in [FIGURE 3](#) consists of a buffer amplifier and an instrument circuit where the instrument circuit[16] consists of a buffer circuit and a differential amplifier[17].

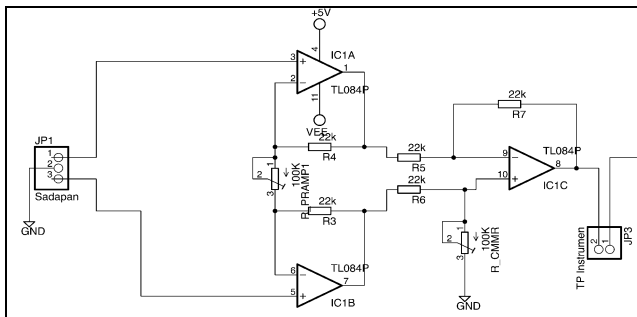

**FIGURE 3.** Instrumentation Amplifier Circuit

#### 2) HIGH PASS FILTER

High Pass Filter as shown in [FIGURE 4](#) is a filter that passes high frequencies and suppresses amplitudes of frequencies lower than the cut-off frequency[18]. The noisy muscle electrical signal that has been obtained from the instrumentation amplifier circuit will be filtered on a high pass filter circuit to pass frequencies above 70 Hz.

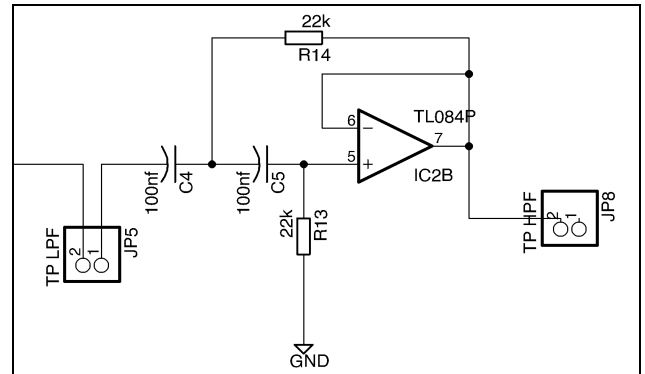

**FIGURE 4.** High Pass Filter Circuit

#### 3) LOW PASS FILTER

Low pass filter as shown in [FIGURE 5](#) is a filter that functions to suppress frequencies above the cut-off frequency and pass frequencies below the cut-off frequency[19]. In the low pass filter circuit, it is used to filter signals with frequencies above 500 Hz so that signals below 500 Hz will be passed.

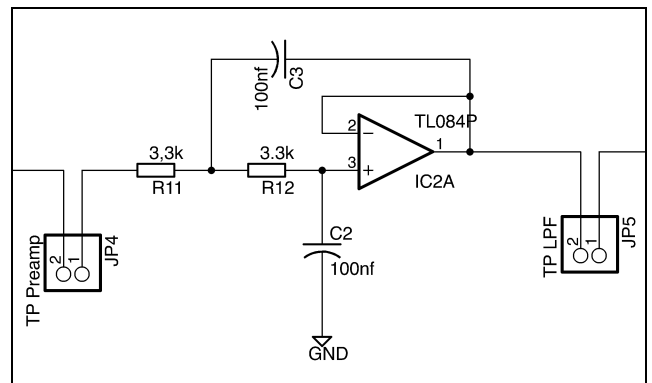

**FIGURE 5.** Low Pass Filter Circuit

#### 4) ADDER CIRCUIT

An adder circuit as shown in [FIGURE 6](#), is a circuit that serves to increase the dc offset of the EMG signal. In this module, the adder circuit consists of a summing amplifier circuit [20] and a voltage divider circuit. The summing amplifier circuit serves to 'add up' the DC voltage coming from the voltage divider circuit and the EMG signal pulse from the HPF circuit. The output of the HPF circuit and voltage divider is connected to pin 3 of IC TL071 as a positive input after each output is serialized with a resistor of the same value. The adder circuit serves to facilitate analog to digital communication between the EMG module circuit and the microcontroller so that the EMG signal can be converted to digital and displayed on a computer.

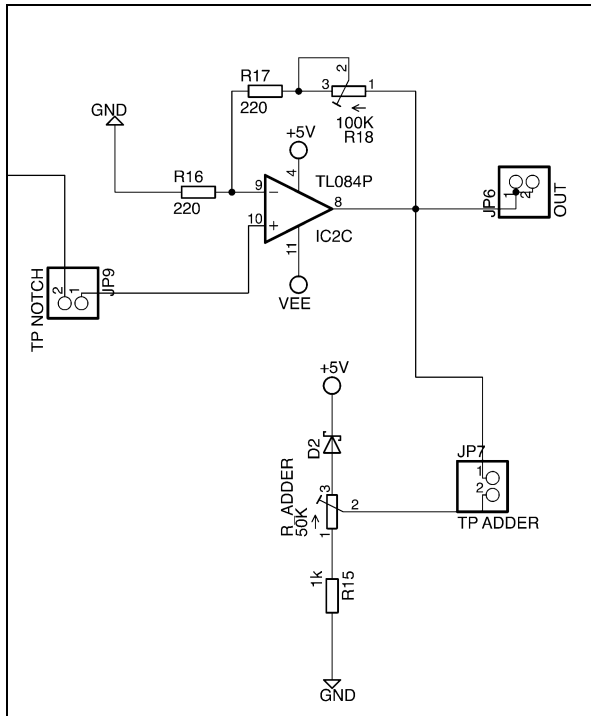

FIGURE 6. Adder Circuit

5) ACCELEROMETER SENSOR

The accelerometer sensor used in this study is the MPU6050 sensor. This sensor works by reading the location of the sensor on the x, y, and z axes. The communication of the MPU6050 sensor uses the I2C model so that the SCL and SDA outputs from the MPU6050 sensor are connected to the SCL and SDA inputs from the Arduino.

III. RESULT

A. EMG DESIGN

The modules as shown as FIGURE 7. that have been planned are then designed, the following is the result of the module design in this study. The module consists of a power supply block, an EMG circuit, an Arduino UNO, a signal input block, and an EOG circuit. This research is combined with the EOG research, but the discussion on EOG is presented in a different thesis.

The baud rate is set to 9600, then the analog output of the EMG circuit is read and converted to digital. The reading result is initialized in the EMG variable.

1) MEASUREMENT

The maximal voltage of the output is 9V (FIGURE 8) because the power supply of the entire circuit is only on +5V and -5V. The higher of the input frequency will reduce the amplitude signal.

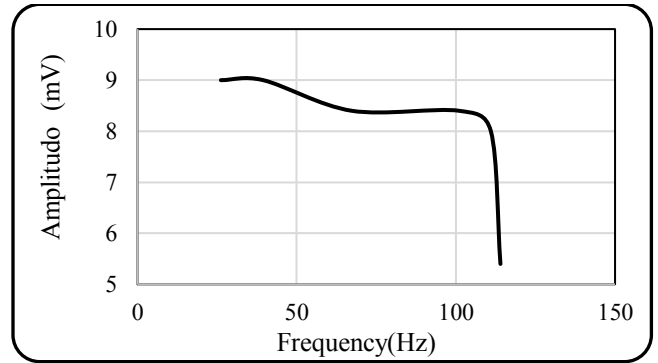

FIGURE 8. Graph of the Instrumentation Amplifier Circuit Output

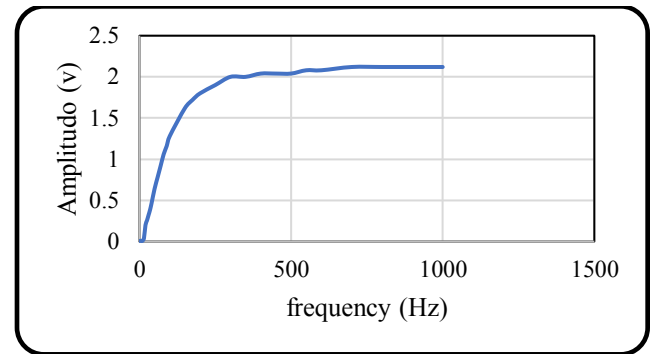

FIGURE 9. HPF Circuit Plotting Graph

The HPF circuit measurement result is indicating that the circuit running properly. Because it can reduce the lower frequency of 70 Hz. The higher input frequency value after 200 Hz, the output of voltage become more stable. The result of plotting the Low Pass Filter is shown in FIGURE 9. Shown graphic output voltage of the circuit.

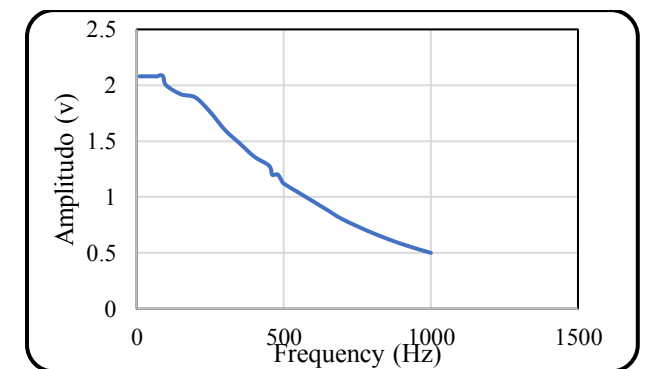

FIGURE 10. LPF circuit plotting graph

The LPF circuit measurement result indicates that the circuit works according to design. It banned the upper frequency of input and passed the lower frequency of the input.

## B. ACCELEROMETER SENSOR MEASUREMENT

MPU6050 sensor is compared with standard measuring instruments at a certain degree value. Measurements were repeated six times. The results of the MPU6050 average and error sensor output are recorded in TABLE 1.

**TABLE 1**  
Accelerometer sensor angle measurement for 30 degree

No	Respondent	Angle Measurement
		Error (%)
1.	1	1,4
2.	2	2,7
3.	3	6,0
4.	4	0,09
5.	5	0,5

The error value shown in TABLE 6 is still relatively low, which indicates the accuracy of the MPU6050 sensor when compared to standard measuring instruments is good enough. After that the sensor is compared with respondents, the respondents are conditioned with any different neck elevation. The output of the sensor is shown in TABLE 2 – 3.

**TABLE 2**  
Accelerometer sensor angle measurement for 45 degree

No	Respondent	Angle Measurement
		Error (%)
1.	1	5,2
2.	2	5,8
3.	3	4,5
4.	4	3,8
5.	5	0,8

**TABLE 3**  
Accelerometer sensor angle measurement for 60 degree

No	Respondent	Angle Measurement
		Error (%)
1.	1	3,24
2.	2	4,4
3.	3	4,8
4.	4	1,2
5.	5	7,7

When the sensor is attached to the respondents to measure the elevation value of the neck angle when the respondent is looking down, the measurement value is not as accurate as a protractor. It was caused by many things. The inaccuracy of

the sensor and also the ability to bend the respondents which did not reach the predetermined angle value.

## C. MEASUREMENT ON RESPONDENTS

Respondents were conditioned to bow with different neck angles for five minutes. An image of the muscle electrical signal from this activity is recorded and shown in FIGURE 10-12. Recording begins when the respondent's neck muscles have contracted at a predetermined neck angle elevation value.

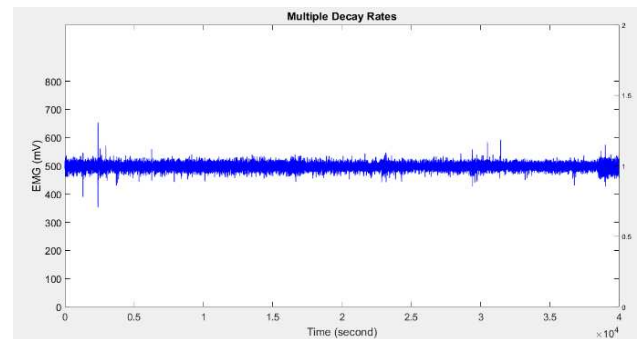

FIGURE 11. First respondent with EMG signal (0°)

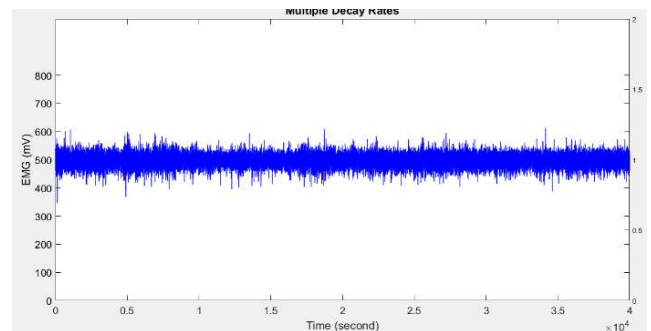

FIGURE 12. First respondent with EMG signal (30°)

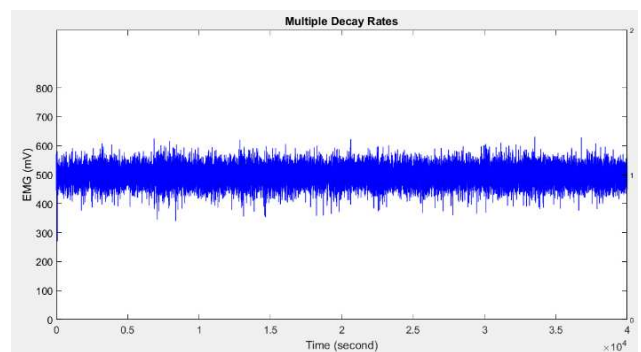

FIGURE 13. First respondent with EMG signal (60°)

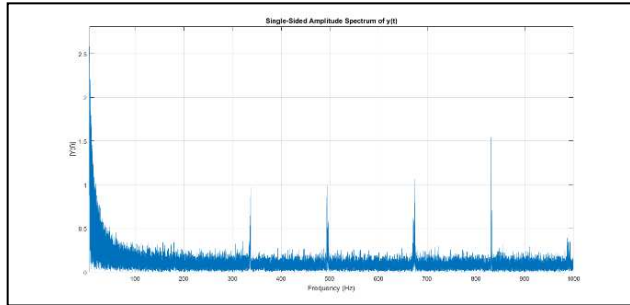

FIGURE 14. FFT first respondent with EMG signal (0°)

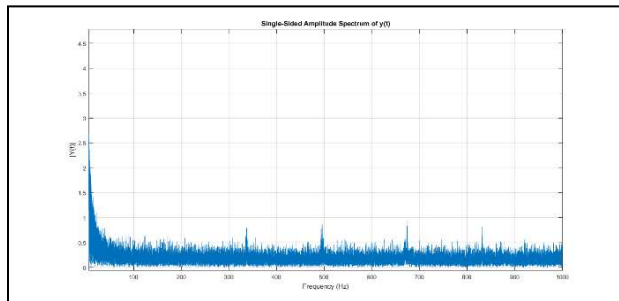

FIGURE 15. FFT first respondent with EMG signal (30°)

FIGURE 13-15 shows that amplitude levels have increased as well as the increase of neck flexion angle. The FFT method uses to observe the difference between each signal.

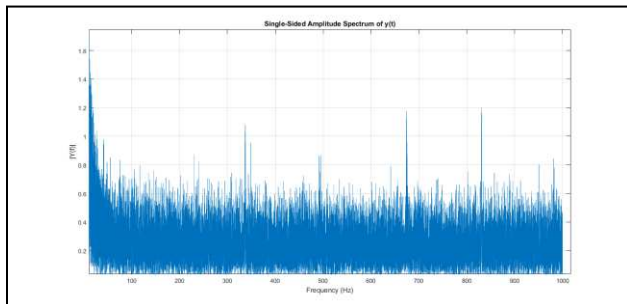

FIGURE 16. FFT first respondent with EMG signal (60°)

From the FFT result can be observed that the level of amplitude increase as long as the neck flexor level of a degree increase. This proofing can be shown in Table IV that shows the value of mean power frequency. This can be proved that the EMG module that builds can successfully show the different level of EMG signal of neck muscle based on the increment of next flexor extend. And the more next flexor increase the more power should be given by muscle to keep the head-on position.

TABLE 4

Measurement result of mean power frequency of respondents

Subjects	Contraction Duration	Mean Power Frequency In Each Neck Elevation Angel (Hz)		
		0°	30°	60°
1	5 minutes	0.1772	0.2582	0.3250
2	5 minutes	0.2025	0.2665	0.3092

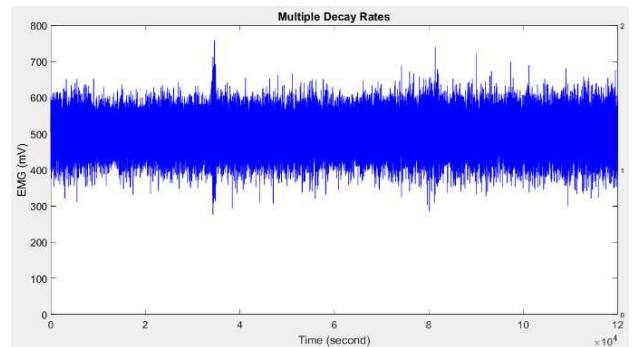

FIGURE 17. Picture of the respondent's EMG signal the first 10 minutes

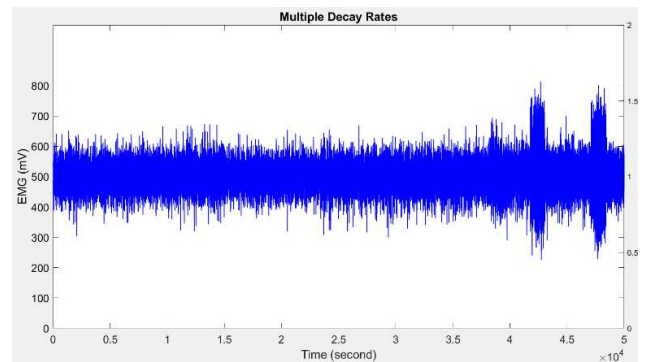
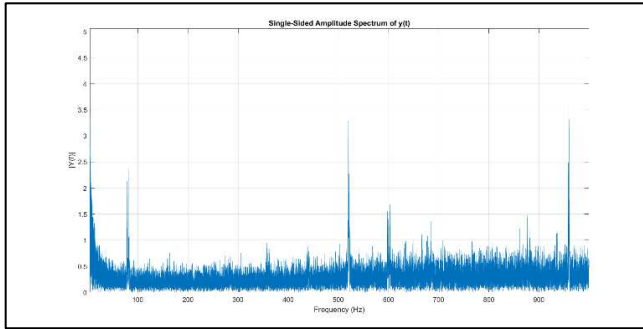
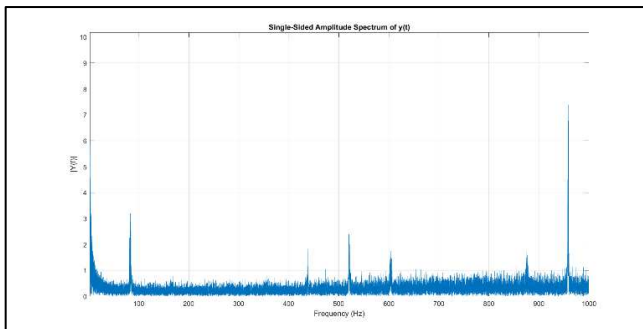

FIGURE 18. Picture of the respondent's EMG signal in the last 10 minutes

Here are the results of measurements on respondents with different conditioning, respondents were asked to bow with an elevation of the neck angle of 30°, then respondents were asked to watch a video for 30 minutes. And look at the difference in the EMG signal at the start of 10 minutes and the end of 10 minutes. The respondents are male, aged 20 years, height 170 cm and weight 70 kg and do not have the habit of playing games.



**FIGURE 19.** FFT Picture of the respondent's EMG signal the first 10 minutes



**FIGURE 20.** FFT Image Respondent's EMG signal in the last 10 minutes

The difference between the EMG signal in the first ten minutes and the last 10 minutes, the amplitude at the last 10 minutes is greater than the first 10 minutes. TABLE 5 is a mean power frequency value from the 10 minutes beginning and the final 10 minutes of conditioning.

**TABLE 5**

Measurement result of mean power frequency of respondents		
Neck Angle	Time	Mean power frequency (Hz)
Elevation	10 minutes early	0.343378225055918
	last 10 minutes	0.361674746835430

#### IV. DISCUSSION

Respondents were conditioned with a distance of 60 cm from the screen. Respondents were conditioned to look down with a neck elevation of  $0^\circ$   $30^\circ$   $60^\circ$ , within 5 minutes. After taking data with respondents, it can be seen that the greater the elevation angle, the greater the amplitude of the EMG signal. It can also be seen that a similar change occurs in the mean power frequency. This shows that the greater the elevation of the neck angle, the greater the muscle power to withstand the weight of the head from gravity. From the experiments that have been carried out, the contraction that causes the neck muscles to change the amplitude of the electrical signal is not looking down normally, but when someone looks

down but their gaze is forward, not downward. The longer the duration of the contraction, the longer the muscle will be burdened.

The MPU6050 sensor is placed in a box and tied to the respondent's head with a ribbon. The box is placed at the top of the earlobe. When the respondent is in an upright position, the sensor output value is  $0^\circ$  and increases as long as the respondent lowers his head. After the experiment is done, the sensor value cannot be stable at one value, it is always unstable. The value after the comma is always changing. It can be concluded that the sensor accuracy is not good.

The results of measurements on respondents with different conditioning, respondents were asked to bow with an elevation of the neck angle of  $30^\circ$ , then respondents were asked to watch a video for 30 minutes. And look at the difference in the EMG signal at the start of 10 minutes and the end of 10 minutes. The respondents are male, aged 20 years, height 170 cm and weight 70 kg and do not have the habit of playing games.

It can be seen the difference between the EMG signal in the first ten minutes and the last 10 minutes, the amplitude at the last 10 minutes is greater than the first 10 minutes. This shows that the muscles work harder in the last 10 minutes, which indicates that time affects the load received by the muscles. If this load is received by the muscles continuously, for a long time it can have a bad effect on the muscles.

The amplitude at the same frequency increased in the last 10 minutes of 30 minutes of conditioning. This proves that the muscle work gets heavier as the contraction time increases. This shows that the module that has been compiled can detect differences in muscle electrical signals and heavier muscle workloads in the last 10 minutes.

#### V. CONCLUSION

The purpose of this study is to design a module that joins the neck elevation gauge and electromyograph. From the results that have been done can be concluded that the MPU6050 sensor has a poor level of accuracy for measuring the elevation of the neck angle on respondents, it is value tends to change quickly, not permanently. EMG signals in the neck muscles require high magnification to be tapped and processed. The level of amplitude is increase as well as neck elevation increase it can be proven that the module can tap electromyography signals and not noise. From the respondent for this research with the conditioning of 5 minutes contraction, the mean power frequency of the downward movement in with a neck angle elevation of  $0^\circ$  is 0.177262 Hz,  $30^\circ$  is 0.25802 Hz,  $60^\circ$  is 0.325092 Hz. However, the suggestion from the author is to replace the MPU6050 sensor with a more accurate one and develop advanced research to process electromyography signals for further benefits.

#### REFERENCES

- [1] C. Deeney and L. W. O'Sullivan, "Effects of cognitive loading and

- force on upper trapezius fatigue,” *Occup. Med. (Chic. Ill)*, vol. 67, no. 9, pp. 678–683, 2017.
- [2] S. Lee, Y. Lee, and Y. Chung, “Effect of changes in head postures during use of laptops on muscle activity of the neck and trunk,” *Phys. Ther. Rehabil. Sci.*, vol. 6, no. 1, pp. 33–38, 2017.
- [3] N. . Vizniak, *Quick Reference Evidence-Based Physical Medicine*, Third. Canada: Profesional Health Systems, 2010.
- [4] C. Cael, *Functional Anatomy: Muskuloskeletal Anatomy, Kinesiology, and Palpation for Manual Therapists*. Philadelphia: Lippincott Williams&Wilkins, 2010.
- [5] J. H. Kang, R. Y. Park, S. J. Lee, J. Y. Kim, S. R. Yoon, and K. I. Jung, “The effect of the forward head posture on postural balance in a long time computer based worker,” *Ann. Rehabil. Med.*, vol. 36, no. 1, pp. 98–104, 2012.
- [6] K. N. C. M, and N. H, “Computer usage and ergonomic risk factors among college students,” *9th Southeast Asian Ergon. Soc. Conf.*, no. October 2008.
- [7] S.-Y. Kim and S.-J. Koo, “Effect of duration of smartphone use on muscle fat,” *J. Phys. Ther. Sci.*, vol. 28, pp. 1669–1672, 2016.
- [8] A. R. Javed, M. U. Sarwar, S. Khan, C. Iwendi, M. Mittal, and N. Kumar, “Analyzing the effectiveness and contribution of each axis of tri-axial accelerometer sensor for accurate activity recognition,” *Sensors (Switzerland)*, vol. 20, no. 8, pp. 1–18, 2020.
- [9] K. Luedtke, J. Mehnert, and A. May, “Altered muscle activity during rest and during mental or physical activity is not a trait symptom of migraine - a neck muscle EMG study,” *J. Headache Pain*, vol. 19, no. 1, 2018.
- [10] J. J. Wan, Z. Qin, P. Y. Wang, Y. Sun, and X. Liu, “Muscle fatigue: General understanding and treatment,” *Exp. Mol. Med.*, vol. 49, no. 10, pp. e384-11, 2017.
- [11] K. K. M. Rahman, M. M. Subashini, M. Nasor, and A. Tawfik, “Development of bio-shields for Arduino Uno,” *2018 Adv. Sci. Eng. Technol. Int. Conf. ASET 2018*, pp. 1–5, 2018.
- [12] D. A. Fitriani, W. Andhyka, and D. Risqiwati, “Design of Monitoring System Step Walking With MPU6050 Sensor Based Android,” *JOINCS (Journal Informatics, Network, Comput. Sci.)*, vol. 1, no. 1, p. 1, 2017.
- [13] S. L. Kumar, M. Swathy, M. Vidya, K. Poojaa, G. Manikandan, and A. Aarthi Jennifer, “Wireless Biosignal Acquisition Electrode module for EMG,” *Proc. Int. Conf. Inven. Commun. Comput. Technol. ICICCT 2018*, no. Iccict, pp. 1839–1844, 2018.
- [14] F. Sadikoglu, C. Kavalcioglu, and B. Dagman, “Electromyogram (EMG) signal detection, classification of EMG signals and diagnosis of neuropathy muscle disease,” *Procedia Comput. Sci.*, vol. 120, pp. 422–429, 2017.
- [15] M. I. Rusydi, M. I. Opera, A. Rusydi, and M. Sasaki, “Combination of flex sensor and electromyography for hybrid control robot,” *Telkomnika (Telecommunication Comput. Electron. Control)*, vol. 16, no. 5, pp. 2275–2286, 2018.
- [16] J. H. Park *et al.*, “A 15-Channel Orthogonal Code Chopping Instrumentation Amplifier for Area-Efficient, Low-Mismatch Bio-Signal Acquisition,” *IEEE J. Solid-State Circuits*, vol. 55, no. 10, pp. 2771–2780, 2020.
- [17] V. A. Nedialkov, “Portable 3- Channel Real-Time Emg Acquisition Device For Use With Myoelectric Prostheses,” vol. 2.
- [18] C. Seguna, A. von Brockdorff, J. Scerri, and K. Scicluna, “Classification of five finger movement, based on a Low-cost, Real-time EMG system,” *BIODEVICES 2020 - 13th Int. Conf. Biomed. Electron. Devices, Proceedings; Part 13th Int. Jt. Conf. Biomed. Eng. Syst. Technol. BIOSTEC 2020*, no. February, pp. 149–159, 2020.
- [19] H. K. Kim, B. S. Chung, K. Il Cho, H. J. Kim, and G. C. Ahn, “Analog front-end for EMG acquisition system,” *J. Semicond. Technol. Sci.*, vol. 18, no. 6, pp. 667–676, 2018.
- [20] E. Yulianto, T. B. Indrato., B. TMN, and Suharyati, “Wheelchair for Quadriplegic Patient with Electromyography Signal Control Wireless,” *Int. J. online Biomed. Eng.*, vol. 16, no. 12, pp. 94–115, 2020.



## APPENDIX

### 1). ATTACHMENT

[https://drive.google.com/drive/folders/18j-hUt2Et\\_O6WYCB-5fhZ9OuUjW16oYR?usp=sharing](https://drive.google.com/drive/folders/18j-hUt2Et_O6WYCB-5fhZ9OuUjW16oYR?usp=sharing)

### 2) THE LISTING PROGRAM FOR ARDUINO

```
void setup() {  
  Serial.begin(9600);  
}  
void loop() {  
  eog1= analogRead(eogvertical);  
  eog2= analogRead(eoghorizontal);  
  emg= analogRead(emg);
```