

Manuscript received October 16, 2021; revised October 22, 2021; November 3, 2021; date of publication November 6, 2021

Digital Object Identifier (DOI): <https://doi.org/10.35882/ijeemi.v3i4.7>

This work is an open-access article and licensed under a Creative Commons Attribution-ShareAlike 4.0 International License ([CC BY-SA 4.0](https://creativecommons.org/licenses/by-sa/4.0/))



Design and Development of Electricity Use Management System of Surabaya State Shipping Polytechnic Based on Decision Tree Algorithm

Adam Meredith Realdo¹, and Anggara Trisna Nugraha¹, and Shubhrojit Misra²

¹ Department of Marine Electrical Engineering, Shipbuilding Institute of Polytechnic Surabaya.

² Department of Electronics & Telecommunication Engineering, Jadavpur University, India.

Corresponding author: anggaranugraha@ppns.ac.id.

ABSTRACT Electrical energy has become a primary need in society, including in education. This is related to the number of electrical equipment used to support teaching and learning activities. However, this is not directly proportional to the students' awareness of the importance of saving energy. From this, the authors create a management system for electric power, which aims to save electricity consumption by limiting the use of electrical loads. In this system, the method used is a decision tree; the goal is to limit and set priorities for electrical loads. When three classes are ON simultaneously, there will be a reduction in the electrical load. There is a website for monitoring and changing the automatic or manual mode in this system. The manual mode is used to control the electrical load according to the status entered on the website. While the automatic mode regulates the use of electrical loads by controlling the ON or OFF conditions using a schedule that has been made, the website also monitors current, voltage, power, energy, and usage costs. The system has been tested with automatic and manual modes for monitoring data on the website. It has data updates every 10 minutes. The system has also been tested by scheduling using a decision tree and compared with scheduling without using a decision tree. From the test results for a day, it can be concluded that the system created is able to save electricity consumption. This is reinforced by a decrease in energy use of 1,17 kWh and a cost of Rp. 1.116.

INDEX TERMS Electrical Energy, Decision Tree, IoT, Load Management, NodeMCU

I. INTRODUCTION

The use of electrical energy is closely related to the basic needs of all levels of society. It is based on the progress of the development of electrical equipment technology and the consumption of electrical energy that continues to increase [1] [2]. The fact is that since 2015 the use of national electricity consumption has shown an increasing trend, reaching 910 kWh/capita, this figure continues to increase until 2019 by 1,084 kWh/capita, and the latest data based on the Ministry of Energy and Mineral Resources reached 1,142 kWh/capita in 2020 [3]. In Indonesia, in particular, the use of electrical energy is carried out with a prepaid system, in which the public is required to purchase a certain amount of electric pulses to obtain electrical energy. The tool used to distribute electrical energy is a kWh meter; electricity distribution can run [4].

Along with the increase in the use of electrical energy, it can impact wasting electrical energy. In the education sector, waste of electrical energy usually occurs due to excessive use

due to forgetting to turn off electrical equipment after use and lack of awareness of students or students on efforts to save electrical energy, so that it can be detrimental to the state [5]. Another condition that can occur is the risk of accidents in the form of short circuits, where the increasing consumption of electrical equipment and excessive current loads are the driving factors for this risk [6]. Several efforts that continue to be encouraged to overcome these conditions are by monitoring and controlling the use of electrical energy to manage the use of electrical energy [7].

Based on this, we can determine the electrical power load that will be used at a certain time, and the electrical load can be turned on or off automatically according to a schedule that has been made with electrical power usage management. In the research that has been done [8], namely the management of household electric power use using the Greedy algorithm, this research already has a schedule for the electrical load, but there has been no reading about the cost of usage and control

using PLC which in terms of costs tends to expensive. Subsequent research has been carried out [9], namely a monitoring and control system for household electricity consumption. This research has no scheduling of electrical loads, and it is only limited to three tools for electrical loads. Further research has been conducted [10] [11], namely the determination of household electrical power using the decision tree method. This research is to determine the amount of household electrical power using the decision tree method.

From some of the supporting literacy above, the author makes a tool to complement the shortcomings of previous research, namely in the form of designing a management system for using electricity at the Surabaya State Shipping Polytechnic using the decision tree method. Based on some of the things above related to the waste of electrical energy, this system was created with the aim of saving the use of electrical energy and controlling the use of electrical loads according to the classroom usage schedule so as to reduce the waste of electrical energy due to negligence of students.

In this system, the decision tree method is used to limit the electrical load used when many classes have concurrent schedules, then the electrical load used will be reduced [12]. This method is used because it makes it easier for the system to control and determine load priorities that are ON or OFF when multiple class schedules are used simultaneously so that it is expected to make the work of the system easier.

II. MATERIAL AND METHODS

A. THE SYSTEM DESIGN

FIGURE 1 is a flowchart diagram of the system.

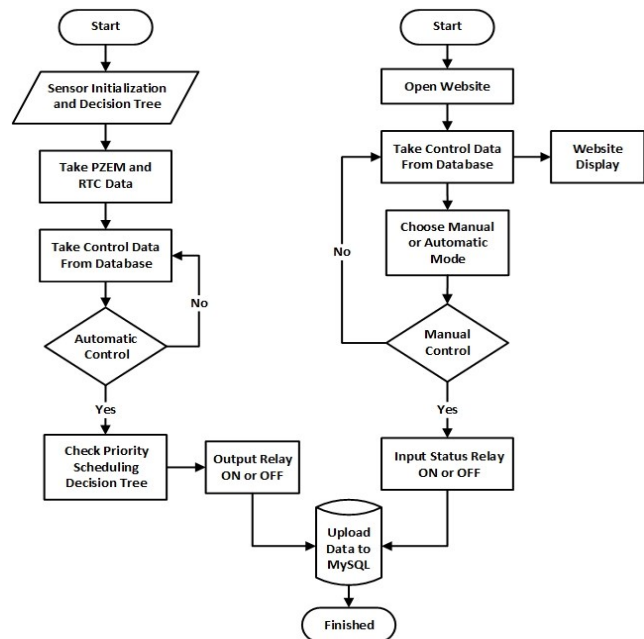

FIGURE 1. System Work Flowchart

At this stage, there is a system workflow in the form of a chart containing the processes carried out by the system. This stage aims to determine the performance of the tool made. This system has two flows, namely, with automatic and manual control. For the system to work automatically, all electrical loads are used according to the schedule that has been made. As for the system work manually, the use of electrical loads is regulated through the website by entering the relay status on the website.

B. ELECTRICAL LOAD DATA

The data collection stage was carried out to determine what electrical loads were used in this study, according to the loads in the classrooms used as shown in TABLE 1.

TABLE 1
Electrical load data

No	Electrical Load	Room
1	Lamp 1	M-106
2	Lamp 2	M-106
3	Lamp 3	M-107
4	Lamp 4	M-107
5	AC	M-108

C. CALCULATION OF BASIC ELECTRICITY RATES

This calculation is used to determine the reading of electricity costs in accordance with the basic tariff groups provided based on the Minister of Energy and Mineral Resources No. 28 of 2016 [13] [14] [15]. The formula for calculating costs for the social, commercial doctoral class can be seen in this equation.

$$\text{Block WBP} = K \times P \times 735 \tag{1}$$

$$\text{Block LWBP} = P \times 735 \tag{2}$$

Description:

K = Price comparison factor of WBP and LWBP according to the load characteristics of the local electricity system (1.4 K 2), determined by the Board of Directors of PT Perusahaan Listrik Negara (Persero)

P = Multiplier is a social commercial (1,3)

WBP = Peak Load Time (17.00-22.00)

LWBP = Outside Peak Load Time

Because the scheduling used is outside the peak load time, only one formula is used, namely LWBP Block

$$\text{LWBP} = 1.3 \times 735 = 955.5 \tag{3}$$

D. DECISION TREE METHOD

In this system, the decision tree method is used as an automatic limitation of load usage when all three classrooms are on at the same time [16] [17]. Then the electrical load of each room will be reduced to reduce power consumption [18].

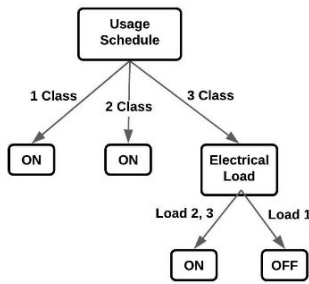

FIGURE 2. Decision Tree

So when the load is used on the schedule, there are 1 or 2 classes that are used simultaneously, then the load will all light up, but when three classes are used simultaneously, there will be a reduction in the load in the form of lights, the purpose is to limit the use of electrical power so that it can save electrical energy [19] [20].

From the decision tree, it can be made into a rule, namely:
 IF usage schedule=1 class THEN load 1,2 and 3 ON
 IF usage schedule=2 class THEN load 1,2 and 3 ON
 IF usage schedule=3 class THEN load 1 OFF & load 2,3 ON

E. HARDWARE DESIGN

At this stage, hardware is made, namely by combining components into one tool that is used to support the work of the tool made. Below is a series of components that have been combined; the power supply as a relay voltage source, Arduino, and buck converter [21]. At the same time, the buck converter is a NodeMCU voltage source. Arduino is programmed to run sensors and actuators and retrieve data from sensors, later the data received by Arduino will be sent to the NodeMCU. Furthermore, the NodeMCU will send the data to the database via the internet, and the data will be displayed on the website. Below is a picture of the hardware design [22].

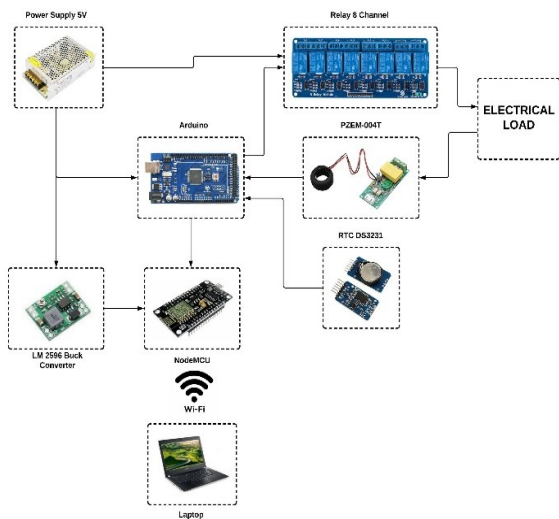

FIGURE 3. Hardware Design

The components used for hardware design include NodeMCU, Arduino Nano, PZEM-004T, RTC DS3231, Power Supply 5V, Buck Converter, Modul Relay 8 Channel, Relay AC, terminal block, and socket. below is the physical form of the hardware that has been completed, which later the load will be connected to the hardware

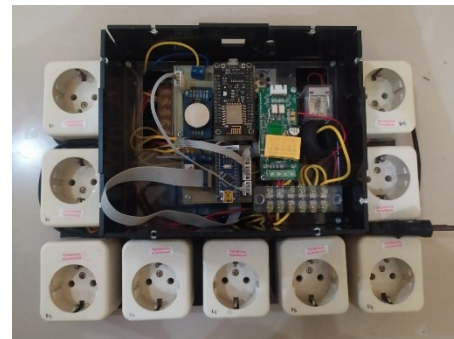

FIGURE 4. Hardware Design

F. SOFTWARE DESIGN

At this stage, software design is carried out using the website as a place to display data from sensors and control electrical loads using actuators.



FIGURE 5. Software Design

The picture above shows a website display that shows data from sensors, namely current, voltage, power, energy, usage costs, and graphs of kWh usage.

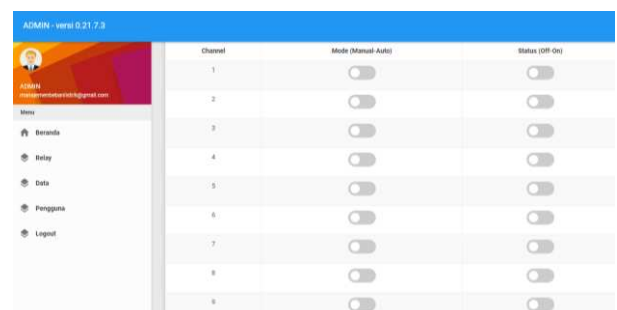

FIGURE 6. Software Design

From the picture above is a website display that is used to change the mode to control the electrical load automatically

according to a schedule or manually by changing the relay status on the website.

III. RESULT

The results of testing the whole system, automatic mode according to schedule and manual mode according to status on the website. evaluate the suitability of electricity cost readings and the application of the decision tree method

A. MANUAL MODE TESTING

In manual mode testing, control ON and OFF on the relay via the website. The goal is to turn on the electrical load manually or outside of the schedule that has been made. This works when there are activities outside of the schedule.

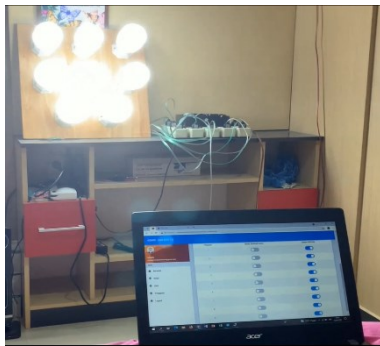

FIGURE 7. Manual Mode Testing

From the picture above, it is known that when the status on the website is in the ON position, the electrical load is on, while when the status on the website is in the OFF position, the electricity load is off.

B. OVERALL TOOL TESTING WITHOUT DECISION TREE

In this test, monitoring is carried out using a Tuesday schedule, with the electrical load in ON conditions in 3 different classes, namely at:

M-106 : 07.50 – 11.30 and 12.10 – 15.50

M-107 : 07.50 – 11.30 and 14.00 – 15.50

M-108 : 07.50 – 11.30 and 12.10 – 15.50

some samples of test data can be seen in **TABLE 2**.

TABLE 2
Test results without decision

No	Time	Current (Ampere)	Voltage (Volt)	Power (Watt)	Energy (kWh)
1	08.00	7,35	219,3	1619,5	0,269
2	08.10	7,35	219,5	1621,2	0,271
3	08.20	7,35	218,4	1619,7	0,270
4	08.30	7,36	219,6	1620,5	0,271
5	08.40	7,37	219,3	1621,3	0,271
6	08.50	7,36	219,6	1620,5	0,271
7	09.00	7,36	218,7	1620,4	0,271
8	09.10	7,34	218,6	1620,4	0,270
9	09.20	7,32	219,5	1619,2	0,269
10	09.30	7,33	220,1	1620,1	0,270

Based on all the data that has been obtained. The results of the electrical load test without a decision tree show that the total energy use is 10,63 kWh, and the reading of the usage cost is Rp. 10.156. Below is the result of testing the system on the website display.

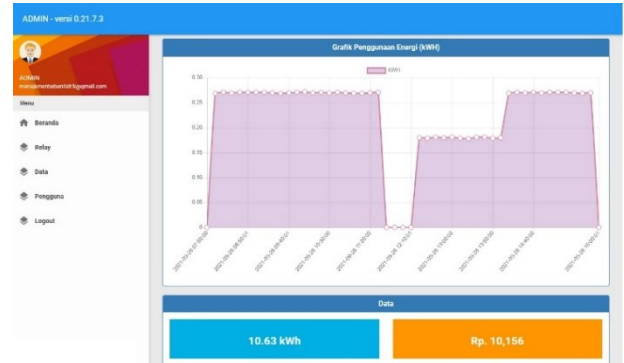

FIGURE 8. Test Results Without Decision Tree

C. OVERALL TOOL TESTING WITH DECISION TREE

This test uses a schedule on Tuesday, the electrical load is scheduled, and the priority of the use of the electricity load will be determined from the schedule; when three classes are used simultaneously, there will be a load that is turned off. Some of the schedules that have been determined are as follows:

M-106 : 07.50 – 11.30 and 12.10 – 15.50

M-107 : 07.50 – 11.30 and 14.00 – 15.50

M-108 : 07.50 – 11.30 and 12.10 – 15.50

some samples of test data can be seen in **TABLE 3**.

TABLE 3
Test results with decision

No	Time	Current (Ampere)	Voltage (Volt)	Power (Watt)	Energy (kWh)
1	08.00	6,35	218,8	1396,1	0,232
2	08.10	6,33	219,4	1395,5	0,231
3	08.20	6,35	218,9	1395,7	0,232
4	08.30	6,34	218,5	1395,6	0,232
5	08.40	6,36	219,4	1396,2	0,233
6	08.50	6,33	221,3	1394,8	0,231
7	09.00	6,34	220,6	1396,3	0,233
8	09.10	6,35	219,2	1395,5	0,232
9	09.20	6,33	219,6	1396,4	0,233
10	09.30	6,35	218,4	1395,6	0,234

The test results by reducing the use of electrical loads using a decision tree show that the total energy use is 9,46 kWh, and the reading of the usage cost is Rp. 9.040. Below is the result of testing the system on the website display.

D. DATA LOSS TEST

In this test, to find out data that was not sent or lost in data transmission. Testing is done by looking at sending data every 10 minutes, whether there is missing data or not. The goal is to determine the level of accuracy of the reading of electrical energy. **FIGURE 9** shows a data loss test.

No	Tanggal	Arus (A)	Tegangan (V)	Daya (W)	Energi (KWH)
1	2021-09-21 16:00:01	0	219.3	0	0
2	2021-09-21 15:50:01	6.33	218.7	1393.2	0.234
3	2021-09-21 15:40:03	6.33	219.5	1395.6	0.232
4	2021-09-21 15:30:02	6.34	218.6	1394.2	0.232
5	2021-09-21 15:20:01	6.34	219.3	1395.6	0.23
6	2021-09-21 15:10:01	6.31	219.5	1394.7	0.231
7	2021-09-21 15:00:03	6.36	219.1	1395.7	0.231
8	2021-09-21 14:50:02	6.33	218.6	1396.3	0.233
9	2021-09-21 14:40:03	6.32	221.6	1395.6	0.234
10	2021-09-21 14:30:01	6.35	217.9	1394.7	0.232
11	2021-09-21 14:20:01	6.32	217.5	1395.6	0.234
12	2021-09-21 14:10:01	6.36	218.4	1396.4	0.235
13	2021-09-21 14:00:02	4.89	219.2	1079.9	0.179

FIGURE 9. Data Loss Test Results

There is no data loss because all data sent every 10 minutes is already on the website display. This shows that the energy reading level in this system has high accuracy (FIGURE 10).

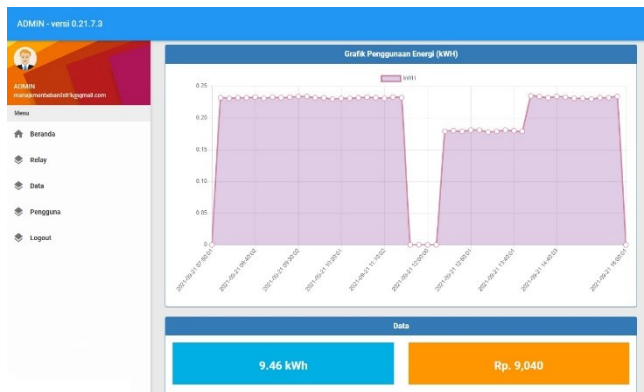

FIGURE 10. Test Results With Decision Tree

E. COMPARISON TESTING SYSTEM

From these tests, data on energy use and cost readings were obtained. Data from scheduling with decision tree obtained energy use of 9,46 kWh and cost reading of Rp. 9.040, while the scheduling data without a decision tree obtained an energy use of 10,63 kWh and a cost reading of Rp. 10.156. Compared to the two data, the energy use decreased by 1,17 kWh, and the usage cost was Rp. 1.116.

IV. DISCUSSION

The test results show that the Arduino microcontroller can read sensors from the RTC in the form of date and time. Arduino is also able to read PZEM sensors in the form of current, voltage, energy, and power. In addition, control and monitoring can be done through the website by sending data using NodeMCU. Testing the accuracy of the data obtained by looking at the data loss test, there is no missing data in this test. System testing related to reading usage costs is according to the calculation, and the use of the decision tree method follows the rules used [23].

In testing the system using the same schedule, there are differences in the use of electrical energy with the decision tree method. In the scheduling test without a decision tree, it is obtained that the use of electrical energy is greater. This is because the decision tree method is used to reduce the electrical load when the third class schedule is used [24].

The weakness of this research is that it has not been tested directly in classroom conditions. This study was compared with previous research [8], namely the design and implementation of electrical power management using a greedy algorithm for home automation; in addition to different test sites in this study, there are also cost readings, and the website is not only used as monitoring but can control the load. Electricity manually and when compared with research [9] which is a monitoring and control system for household electricity consumption based on IoT and android, in addition to different test sites in this study, there is also electrical load scheduling, and the website is not only used as monitoring but can control the electrical load manually which in previous studies did not exist [25].

V. CONCLUSION

In this study, the design of a management system for the use of electrical power with parameters of voltage, current, power, energy, and usage costs was carried out. This system uses Arduino as a controller and a website as an interface. NodeMCU is used to send data from Arduino and websites. In addition, this study controls the electrical load according to the schedule and can also control it manually through the website. Websites for monitoring have data updates every 10 minutes. Testing is only on a simulation scale.

In the future, this research still needs a lot of development and refinement. Extending the control with additional parameters can increase the practicality of this system. Furthermore, experiments can be carried out in the classroom directly to get more accurate data. Thus, it is possible to test the level of reliability of this system.

VI. REFERENCES

- [1] F. H. B. C. F. H. Y. Zhun Yu, "A decision tree method for building energy demand modeling," *Energy and Buildings*, vol. 42, no. 10, pp. 1637-1646, 2010.
- [2] Y. L. Yan-yan Song, "Decision tree methods: applications for classification and prediction," *Shanghai archives of psychiatry*, vol. 27, no. 2, p. 130, 2015.
- [3] M. M. D. R. Anggara Trisna Nugraha, "Solutions For Growing the Power Factor Prevent A Reactive Electricity Tariff And Decrease Warmth On Installation With Bank Capacitors," *Applied Technology and Computing Science Journal*, vol. 4, no. 1, pp. 35-46, 2021.
- [4] D. P. Anggara Trisna Nugraha, "Design of Hybrid Portable Underwater Turbine Hydro and Solar Energy Power Plants: Innovation to Use Underwater and Solar Current as Alternative Electricity in Dusun Dongol Sidoarjo," *Journal of Electronics, Electromedical Engineering, and Medical Informatics (JEEEMI)*, vol. 3, no. 2, pp. 93-98, 2021.

- [5] L. S. A. Cristiano M. A. Gomes, "Advocating the Broad Use of the Decision Tree Method in Education," *Practical Assessment Research, and Evaluation*, vol. 22, no. 1, p. 10, 2017.
- [6] M. J. Aitkenhead, "A co-evolving decision tree classification method," *Expert Systems with Applications*, vol. 34, no. 1, pp. 18-25, 2008.
- [7] G. Pappalardo, S. Cafiso, A. Di Graziano and A. Severino, "Decision Tree Method to Analyze the Performance of Lane Support Systems," *Sustainability*, vol. 13, no. 2, p. 846, 2021.
- [8] G. C. N. S. N.D. Hatzargyriou, "A decision tree method for on-line steady state security assessment," *IEEE Transactions on Power Systems*, vol. 9, no. 2, pp. 1052-1061, 1994.
- [9] A. M. R. D. P. A. M. R. F. I. L. N. S. N. P. Z. a. M. S. M. Anggara Trisna Nugraha, "Use Of ACS 712ELC-5A Current Sensor on Overloaded Load Installation Safety System," *ATCSJ (APPLIED TECHNOLOGY AND COMPUTING SCIENCE JOURNAL)*, vol. 4, no. 1, pp. 47-55, 2021.
- [10] A. M. E. E. Badr HSSINA, "A comparative study of decision tree ID3 and C4.5," (*IJACSA*) *International Journal of Advanced Computer Science and Applications*, vol. 4, no. 2, pp. 13 -19, 2014.
- [11] W. e. a. Gao, "A study on the cyclist head kinematic responses in electric-bicycle-to-car accidents using decision-tree model," *Accident Analysis & Prevention*, vol. 160, no. https://doi.org/10.35793/jti.9.1.2016.14141, p. 106305, 2021.
- [12] J. X. Y. L. Xi Luo, "Extraction of dynamic operation strategy for standalone solar-based multi-energy systems: A method based on decision tree algorithm," *Sustainable Cities and Society*, vol. 70, p. 102917, 2021.
- [13] J. R. E. F. S. Natalia Mosquera, "Medium-term risk analysis in electricity markets: a decision-tree approach," *International Journal of Energy Sector Management*, vol. 2, no. 3, pp. 318 - 339, 2008.
- [14] M. A. A. O. J. & Y. N. Hambali, "Electric Power Load Forecast Using Decision Tree Algorithms," *Computing, Information Systems, Development Informatics & Allied Research Journal*, vol. 7, no. 4, pp. 29-42, 2016.
- [15] A. S. S. W. A. S. a. E. M. C. M. P. LaBar, "Status of the GT-MHR for Electricity Production," London, 2003.
- [16] R. Kumar, B. Singh, D. T. Shahani, A. Chandra and K. Al-Haddad, "Recognition of Power-Quality Disturbances Using S-Transform-Based ANN Classifier and Rule-Based Decision Tree," *IEEE Transactions on Industry Applications*, vol. 51, no. 2, pp. 1249 - 1258, 2014.
- [17] F. Sioshansi, *Competitive electricity markets: design, implementation, performance*, Elsevier, 2011.
- [18] L. H. J. K. S. W. Heiko Milde, "Qualitative Analysis of Electrical Circuits for Computer-based Diagnostic Decision Tree Generation," *Proc. QR'99, 13th International Workshop on Qualitative Reasoning about Physical Systems*, 1999.
- [19] S. K. Chatterjee, S. Das, K. Maharatna, E. Masi, L. Santopolo, I. Colzi, S. Mancuso and A. Vitaletti, "Comparison of decision tree based classification strategies to detect external chemical stimuli from raw and filtered plant electrical response," *Sensors and Actuators B: Chemical*, vol. 249, pp. 278 - 295, 2017.
- [20] P. S. a. L. C. M. Shaffer, *Research as a guide for curriculum development: An example from introductory electricity. Part II: Design of instructional strategies*, *American Journal of Physics*, vol. 60, no. 11, pp. 1003 - 1013, 1992.
- [21] P. D. Barba, "Multiobjective shape design in electricity and magnetism," *Lecture Notes in Electrical Engineering*, vol. 47, pp. 1 - 330, 2010.
- [22] M. F. Basar, A. A. Rahman, A. Din, Yahaya and Z. Mahmud, "Design and development of green electricity generation system using ocean surface wave," in *Proceedings of the International Conference on Energy and Sustainable Development: Issues and Strategies (ESD 2010)*, Chiang Mai, Thailand, 2010.
- [23] S. S. D. P. Rendi Munadi, "Design and Implementation of a New Monitoring System for Electrical Energy Consumption with Smart Metering based on Internet of Things (IoT)," no. DOI 10.5013/IJSSST.a.20.02.11.
- [24] X. Savarimuthu, U. Rao and M. F. Reynolds, "Go Green for Environmental Sustainability," *Go Green for Environmental Sustainability*, 2021.
- [25] S. V. a. V. Randima, "Design IoT Based Smart Electricity Power Saving University: Analysis from a Lecture Hall," *Journal of Computer Science*, vol. 15, pp. 1097-1107, 2019.