

Heat exchangers are important equipment for the process of placing heat. The most widely used type of heat exchanger is shell and tube. This type is widely used because of its simple and easy design. Design of shell and tube heat exchangers is done by the side or shell variations to get the desired performance. Therefore, research is conducted to study the effect of tube thickness on heat transfer, pressure drop, and stress that occurs in the shell and tube heat exchanger so that the optimal tube thickness is obtained.

In this research, the activities carried out are the design of heat exchangers for the production of oxygen with a capacity of 30 tons/day. The standard used in this study is the 9th edition heat exchanger design guidance document compiled by the Tubular Exchanger Manufacturer Association (TEMA). Analysis of the tube thickness effect on heat transfer, pressure drop, and stress was carried out using the SimScale platform.

The effect of variations in tube thickness on heat transfer is that the thicker the tube, the lower the heat transfer effectiveness. The highest value of the heat exchanger effectiveness is 0.969 at the tube thickness variation of 0.5 mm. The lowest value of the heat exchanger effectiveness is 0.931 at the tube thickness variation of 1.5 mm. The effect of variations in tube thickness on pressure drop is that the thicker the tube, the higher the pressure drop. The highest value of pressure drop is in the variation in tube thickness of 1.5 mm, 321 Pa. The lowest value of drop pressure is in the variation of 0.5 mm tube thickness, which is 203 Pa. The thickness of the tube also increases the maximum stress on the components of the shell, head, tubesheet, baffle, and saddle, but the value is fluctuating

Keywords: heat exchanger, pressure drop, heat transfer, stress analysis, tube thickness

AN ANALYSIS OF TUBE THICKNESS EFFECT ON SHELL AND TUBE HEAT EXCHANGER

Krisdiyanto

Master of Engineering, Lecturer*

E-mail: krisdiyanto@umy.ac.id

Rahmad Kuncoro Adi

Bachelor Degree, Student*

E-mail: rahmad.kuncoro.2016@umy.ac.id

Sudarisman

Associate Professor, Lecturer*

E-mail: sudarisman@umy.ac.id

Sinin Bin Hamdan

Professor, Lecturer

Department of Mechanical and

Manufacturing Engineering

Universiti Malaysia Sarawak

Kota Samarahan, Sarawak, Malaysia, 94300

E-mail: hsinin@unimas.my

*Department of Mechanical Engineering

Universitas Muhammadiyah Yogyakarta

Jl. Brawijaya, Kasihan, Bantul Yogyakarta, Indonesia, 55183

Received date 04.01.2021

Accepted date 02.02.2021

Published date 26.02.2021

Copyright © 2021, Krisdiyanto, Rahmad Kuncoro Adi, Sudarisman, Sinin Bin Hamdan

This is an open access article under the CC BY license

(<http://creativecommons.org/licenses/by/4.0>)

1. Introduction

Heat exchanger is a device used to transfer heat energy between two fluids or more without mass transfer [1]. The equipment is mostly used in the chemical, nuclear energy, and oil industries [2]. The most common type of heat exchanger is shell and tube heat exchanger [3]. Design of a heat exchanger needs a standard [4]. The standard document for designing shell and tube heat exchangers is a document published by the Tubular Exchanger Manufacturers Association [5]. The standard for designing shell and tube heat exchangers published by the Tubular Exchanger Manufacturer Association is not optimal, so it is needed to change the dimensions of its components to acquire optimal performance and production cost [6]. Researchers feel that the existing standards are not efficient, so many researchers are still looking for the best parameters in the design. Dimensional changes in the tool affect equipment performance. Dimensional changes in the heat exchanger components affect the value of heat transfer coefficient and pressure drop [7–9]. Several components will deviate from the original standards

if they follow industry requirements [8]. One of the parameters that affect the value of heat transfer, pressure drop, and stress is the change of tube thickness. Design optimization is used to acquire minimal pressure drop, so the operating costs on pumps and fans can be reduced [9]. Dimensional changes in the shell and tube heat exchanger components not only affect heat transfer and pressure drop but can also affect the stress on the equipment [10]. Stress distribution influences the safety of equipment when operating [11]. Therefore, this study aims to determine the effect of tube thickness on heat transfer, pressure drop, and stress, so the results can be used as a reference of heat exchanger tube dimensions.

2. Literature review and problem statement

The study on the effect of tube wall thickness on heat transfer was carried out. The methods used in this research are experiment and computational fluid dynamics (CFD). The result of this study is that the thickness of the tube walls affects the heat transfer convection [12]. On the other

hand, the study on the effect of tube dimensions was made. The tube is modified so that it has fins. The heat transfer and pressure drop were investigated. The computational fluid dynamics method was used. The result of this study is that the increasing of fins height makes the increasing of heat transfer and pressure drop, while the decreasing of tube thickness makes the increasing of heat transfer and decreasing of pressure drop [13].

The research about the effect of conduction on tube walls was conducted. The method used is the finite element method. The finite element method is implemented with the help of MATLAB software. This study shows that tubes with a thickness of 0.5 mm have a better temperature profile than with a thickness of 1 mm to 2 mm [14].

Research on the effect of thickness and material properties in perforated cylindrical tubes on heat transfer and waveform distortion was conducted. The method used is the calculation of thermal resistance and the estimated input algorithm. The input algorithm estimation method is implemented with the help of Fluent software. This study shows that tube thickness affects heat transfer [15].

The study on the effect of the wall thickness of material on heat transfer was carried out. The method used is mathematical modelling with the help of MATLAB software. The results of this study indicate that the thickness of a material affects heat transfer [16].

Shell diameter, tube bundle diameter, tube outer diameter, tube pitch, tube arrangement, number of tube passes, and number of tubes can be determined from the standards published by TEMA. However, it is necessary to optimize some of these standards to obtain the desired heat exchanger performance [17]. On the other hand, the research was performed, which did not use the standards published by TEMA for some of heat exchanger components, and variations were made to get the best value in terms of performance and production costs [6].

The research that has been done is to analyze the effect of dimensions on pressure drop and heat transfer. At the same time, the dimensions affect the stress that occurs. Stress analysis is used to determine the effect of variations in tube thickness on the maximum and average stresses that occur, but the previous research has not studied the stress condition in the equipment. The maximum stress analysis in the design is used to protect it from failure [18], and the average stress analysis is used to increase the efficiency of the material used [19]. The effect of stress on the dimensions of the shell and tube heat exchanger has never been carried out, so research on the effect of dimensions on stress is necessary for this study.

3. The aim and objectives of the study

This study aims to determine the change of heat exchanger characteristics (flow, heat transfer, and stress) that have varied tube thickness, so the results can be used as a reference to determine the indicators of heat exchanger characteristics.

To achieve the aim, the following objectives are accomplished:

- to determine the effect of tube thickness on heat distribution by using computer simulation;
- to determine the effect of tube thickness on pressure drop by using computer simulation;

- to determine the effect of tube thickness on stress distribution by using computer simulation;
- to access the indicators of heat exchanger effectiveness.

4. Methods of research

This research begins with making geometry with CAD-based software. CAE can convert complex physics problems and then convert them into mathematical domains to solve [20]. The geometric specifications of the heat exchanger used in this study are presented in Table 1. The heat exchanger specifications refer to the standards published by the Tubular Exchanger Manufacturers Association. The tube thickness used in this study was 0.5 mm, 0.6 mm, 0.7 mm, 0.8 mm, 0.9 mm, 1.0 mm, 1.1 mm, 1.2 mm, 1.3 mm, 1.4 mm, 1.5 mm.

Table 1

Heat Exchanger Specifications

Type	BEM (horizontal)
Material	Stainless Steel 304
Safety Factor	2
Yield Stress	205 MPa
Allowable Stress	102.5 MPa
Shell Diameter	273.1 mm
Shell Thickness	3.4 mm
Tubesheet Diameter	266.3 mm
Tubesheet Thickness	19.1 mm
Baffle Type	Segmental
Baffle Cut	25 %
Number of Baffles	2
Number of Tie Rod	4
Tie Rod Diameter	9.5 mm
Tube Diameter	19.05 mm
Tube Thickness	0.5 mm
Number of Tube	64
Tube Pattern	Triangular
Internal Pressure (shell)	0.36 MPa
Internal Pressure (tube)	0.23 MPa
Shell Inlet Temperature	75.26 °C/348.26 K
Tube Inlet Temperature	500 °C/773 K
Cooling Fluid Mass Flowrate	0.7316 kg/s
Hot Fluid Mass Flowrate	0.0386 kg/s
Cooling Fluid Density	1.57×10 ⁻⁹ kg/m ³
Reynolds Number of Hot Fluid	989
Inlet Diameter of Hot Fluid	198.204 mm

The geometry generated by CAD-based software is then imported into the SimScale platform. The geometry is presented in Fig. 1. The SimScale platform is used to analyze heat transfer, pressure drop, and stress.

Simulation results need to be validated [21]. The allowable deviation rate is a maximum of 5 % [22]. The simulation results consist of the distribution of temperature, fluid pressure, and von Mises stress. The hot fluid outlet temperature is used to calculate the heat transfer effectiveness. Equation (1) was used to calculate the effectiveness of heat transfer.

$$\varepsilon-NTU = \frac{C_{tube} (T_{tube.in} - T_{tube.out})}{C_{min} (T_{tube.in} - T_{shell.in})}, \tag{1}$$

where:

- $\varepsilon \cdot NTU$ – heat exchanger effectiveness;
- C_{tube} – specific heat of hot fluid (W/K);
- C_{min} – specific heat of cooling fluid (W/K);
- $T_{tube.in}$ – tube inlet temperature (K);
- $T_{tube.out}$ – tube outlet temperature (K);
- $T_{shell.in}$ – shell inlet temperature (K).

Validation of the temperature distribution is done by comparing the temperature value in the inlet of the simulation results with the temperature value entered on the SimScale platform. Validation of the distribution of fluid pressure is carried out by comparing the value of the pressure drop in the coolant fluid with the results of calculations using equation (2) [23].

$$\Delta p = \frac{f \cdot L \cdot \rho_t \cdot u_m^2}{2 \cdot d_i} \quad (2)$$

where:

- Δp – pressure drop (Pa);
- f – friction factor;
- L – tube length (m);
- ρ_t – hot fluid density (kg/m³);
- u_m – hot fluid velocity (m/s).

The friction factor is calculated by equation (3).

$$f = \frac{64}{Re} \quad (3)$$

where:

- f – friction factor;
- Re – hot fluid Reynolds number.

Hot fluid velocity is calculated by equation (4).

$$u_m = \frac{\dot{m}_t}{\rho_t \cdot A_t} \quad (4)$$

where:

- U_m – hot fluid velocity (m/s);
- \dot{m} – hot fluid mass flowrate (kg/s);
- ρ_t – hot fluid density (kg/m³);
- A – cross flow area (m²).

Stress validation is done by comparing the von Mises stress value on the shell of the simulation results with the results of the calculation using equation (5).

$$\sigma_{vm} = \sqrt{\sigma_H^2 - \sigma_H \cdot \sigma_L + \sigma_L^2} \quad (5)$$

where:

- σ_{vm} – shell stress (MPa);
- σ_L – longitudinal stress (MPa);
- σ_H – hoop stress (MPa).

Longitudinal stress can be calculated by equation (6) and Hoop stress can be calculated by equation (7) [24].

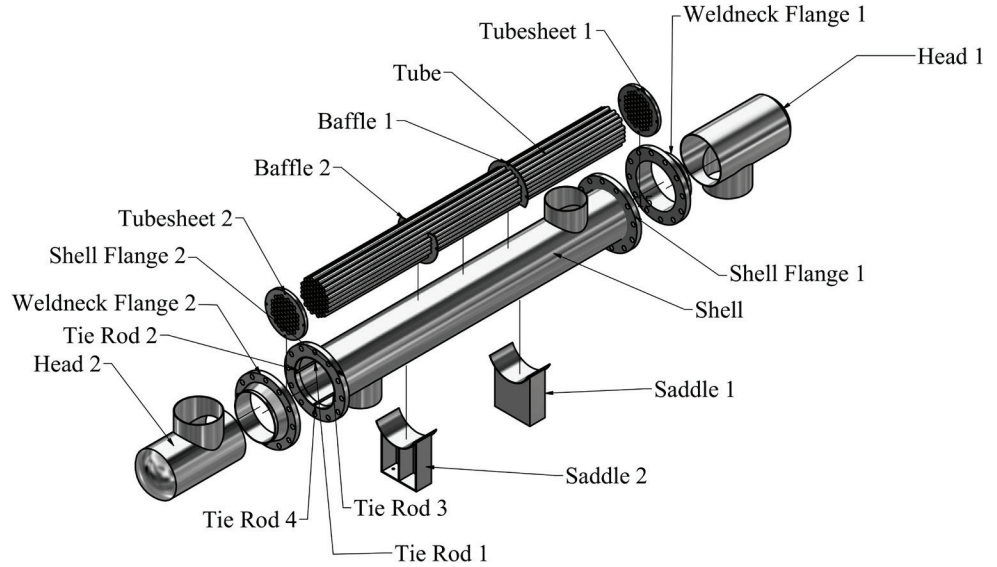

Fig. 1. Geometry of shell and tube heat exchanger

$$\sigma_L = \frac{P \cdot d}{4t} \quad (6)$$

$$\sigma_H = \frac{P \cdot d}{2t} \quad (7)$$

where:

- P – internal pressure (MPa);
- d – shell diameter (m);
- t – shell thickness (m).

Overdesign occurs when the average stress on the heat exchanger component is not the same as the permitted stress of the material used. Overdesign can be calculated using equation (8) [25].

$$\text{Overdesign} = \frac{|\sigma_{allowable} - \sigma_{average}|}{\sigma_{average}} \times 100\% \quad (8)$$

where:

- Overdesign – overdesign (%);
- $\sigma_{allowable}$ – allowable stress (Pa);
- $\sigma_{average}$ – average stress (Pa).

5. Research results

5. 1. Research results of tube thickness effect on heat transfer

The temperature distribution simulation results are shown in Fig. 2. The inlet fluid temperature at all variations is 773.223 K. This result is the same as the temperature of the hot fluid at the inlet. The hot fluid outlet temperature varies. The inlet and outlet temperatures are used to calculate heat exchanger effectiveness. The outlet temperature and heat exchanger effectiveness are presented in Table 2.

The relationship between tube thickness and heat exchanger effectiveness is presented in Fig. 3. The graph shows that if the tube thickness increases, the heat exchanger effectiveness will decrease. This applies to the tube thickness interval of 0.5 mm, 0.6 mm, 0.7 mm, 0.8 mm, 0.9 mm, 1.0 mm, 1.1 mm, 1.2 mm, 1.3 mm, 1.4 mm, and 1.5 mm.

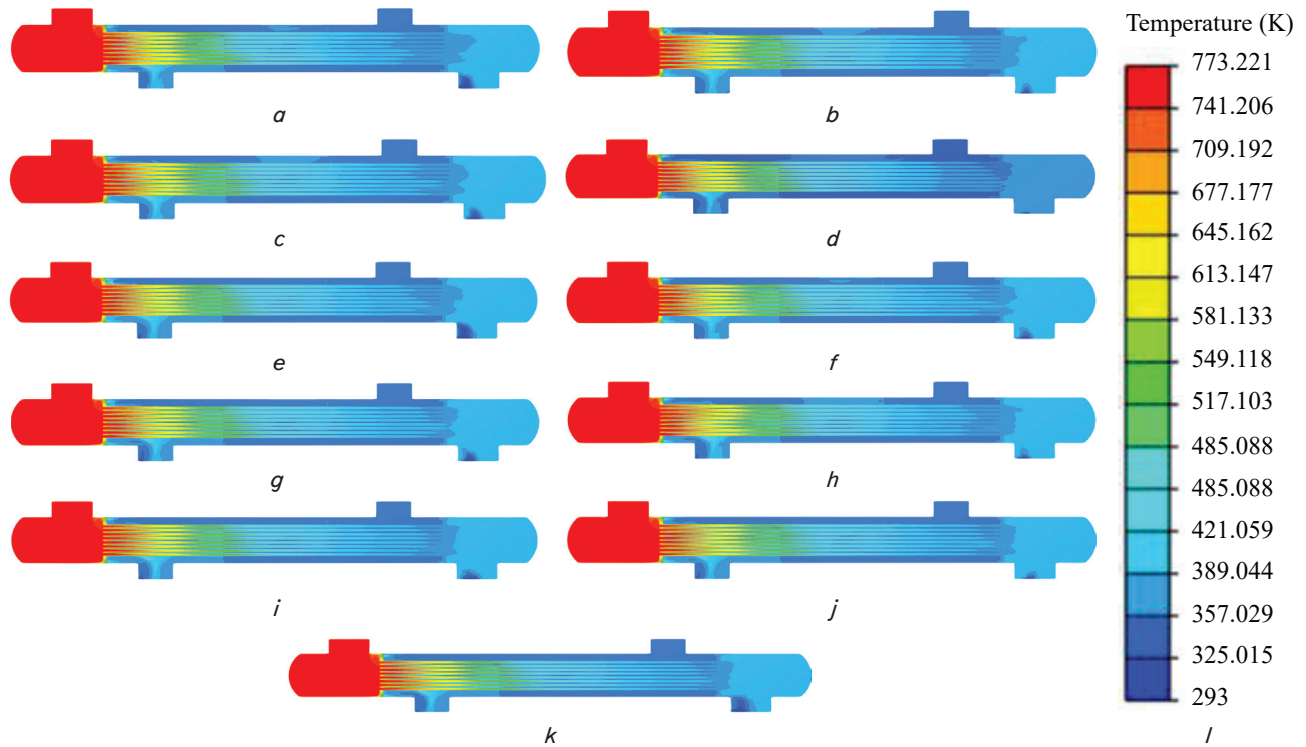

Fig. 2. Temperature distribution of simulation, tube thickness variations: *a* – 0.5 mm; *b* – 0.6 mm; *c* – 0.7 mm; *d* – 0.8 mm; *e* – 0.9 mm; *f* – 1.0 mm; *g* – 1.1 mm; *h* – 1.2 mm; *i* – 1.3 mm; *j* – 1.4 mm; *k* – 1.5 mm; *l* – temperature scale

Table 2
Simulation Results of Hot Fluid Temperature and Heat Exchanger Effectiveness

No.	Tube Thickness (mm)	Hot Fluid Outlet Temperature (K)	Heat Exchanger Effectiveness (ϵ -NTU)
1	0.5	361.32	0.969
2	0.6	366.29	0.958
3	0.7	367.57	0.955
4	0.8	367.82	0.954
5	0.9	368.85	0.952
6	1.0	370.61	0.948
7	1.1	370.89	0.947
8	1.2	371.97	0.945
9	1.3	373.18	0.942
10	1.4	374.71	0.938
11	1.5	377.56	0.931

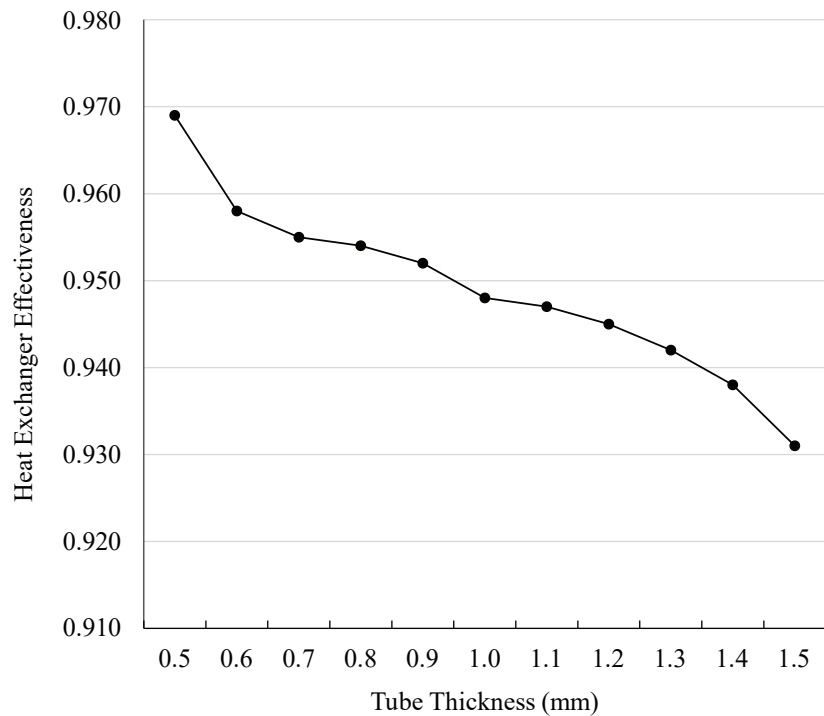

Fig. 3. Tube thickness vs heat exchanger effectiveness

The performance of heat transfer is affected by heat exchanger effectiveness. From Fig. 3, it is shown that tube thickness affects heat exchanger effectiveness, so heat exchanger effectiveness is better on the thinnest tube wall.

5.2. Research results of tube thickness effect on pressure drop

The simulation results of the pressure distribution in the coolant fluid and hot fluid are presented in Fig. 4, 5. The pressure drop values in the cooling fluid and hot fluid are presented in Tables 3, 4. The pressure distribution simula-

tion results are validated using equation (2), which results are shown in Table 4.

Table 3

Simulation Results of Coolant Fluid Pressure Drop

Tube Thickness (mm)	Cold Fluid Pressure Drop (Pa)
0.5	15560.78

Table 4

Hot Fluid Pressure Drop

No.	Tube Thickness (mm)	Hot Fluid Pressure Drop (Pa)		Error (%)
		SimScale	Manual Calculation	
1	0.5	203	198	2.5
2	0.6	208	207	0.5
3	0.7	222	215	3.3
4	0.8	231	228	1.3
5	0.9	242	237	2.1
6	1.0	253	248	2.1
7	1.1	263	263	0.0
8	1.2	275	274	0.4
9	1.3	288	287	0.4
10	1.4	303	299	1.0
11	1.5	321	319	0.6

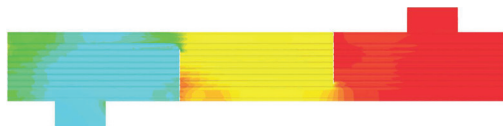
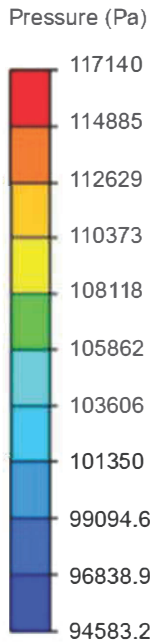

Fig. 4. Coolant fluid pressure distribution

The relationship between tube thickness and pressure drop in the hot fluid is presented in Fig. 6. The graph shows that if the tube thickness increases, the pressure drop will also increase. This applies to the tube thickness of 0.5 mm, 0.6 mm, 0.7 mm, 0.8 mm, 0.9 mm, 1.0 mm, 1.1 mm, 1.2 mm, 1.3 mm, 1.4 mm, and 1.5 mm.

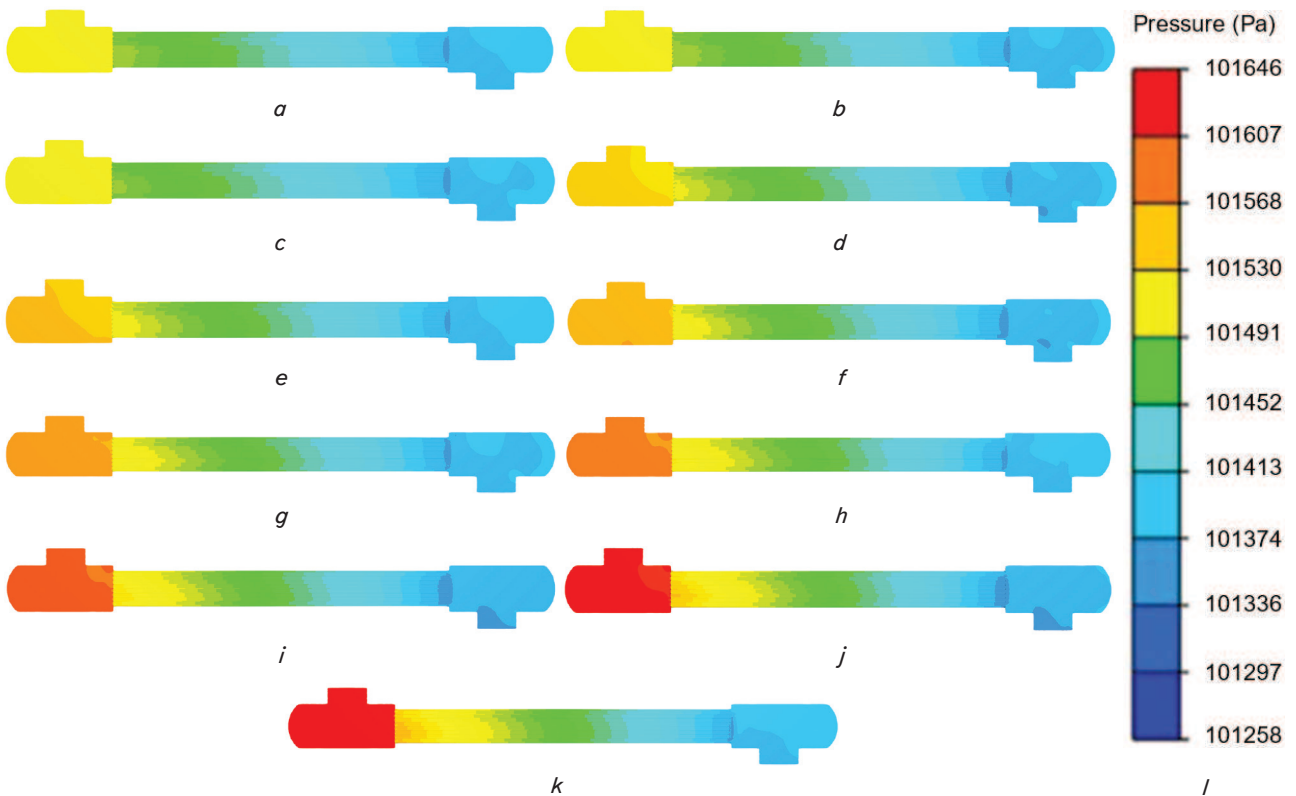

Fig. 5. Hot fluid pressure distribution, tube thickness variations: a – 0.5 mm; b – 0.6 mm; c – 0.7 mm; d – 0.8 mm; e – 0.9 mm; f – 1.0 mm; g – 1.1 mm; h – 1.2 mm; i – 1.3 mm; j – 1.4 mm; k – 1.5 mm; l – pressure scale

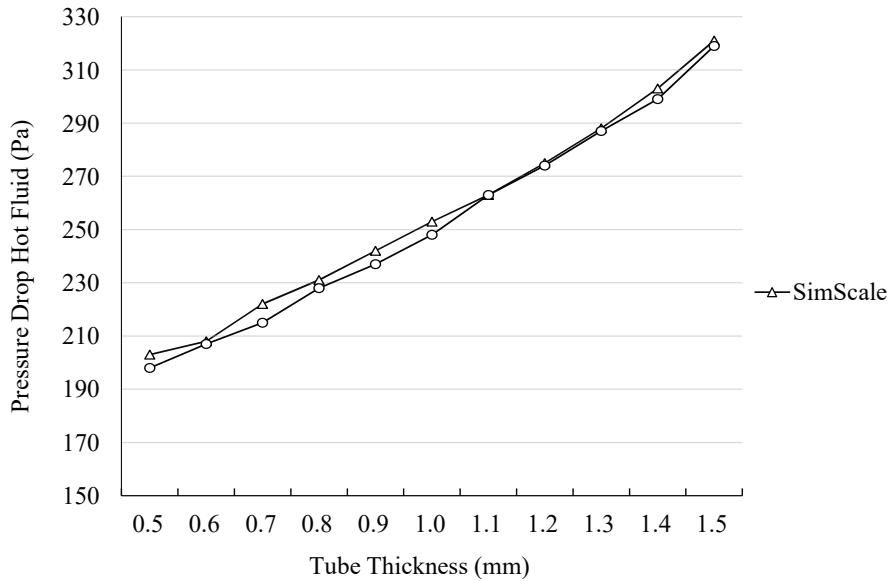

Fig. 6. Hot fluid pressure drop

From Fig. 6, the results of SimScale and manual calculation of hot fluid pressure drop have the same trend and the maximum of the difference value of these methods is 3.3%. If the tube thickness increases, the pressure drop of hot fluid will also increase. So, pressure drop can be minimized by decreasing tube thickness.

5.3. Research results of tube thickness effect on maximum and average stress

Manual calculations validate the results of the von Mises stress distribution simulation. The points used to validate the von Mises stress are presented in Fig. 7. The comparison of the simulated von Mises stresses and the manual calculation are presented in Table 5.

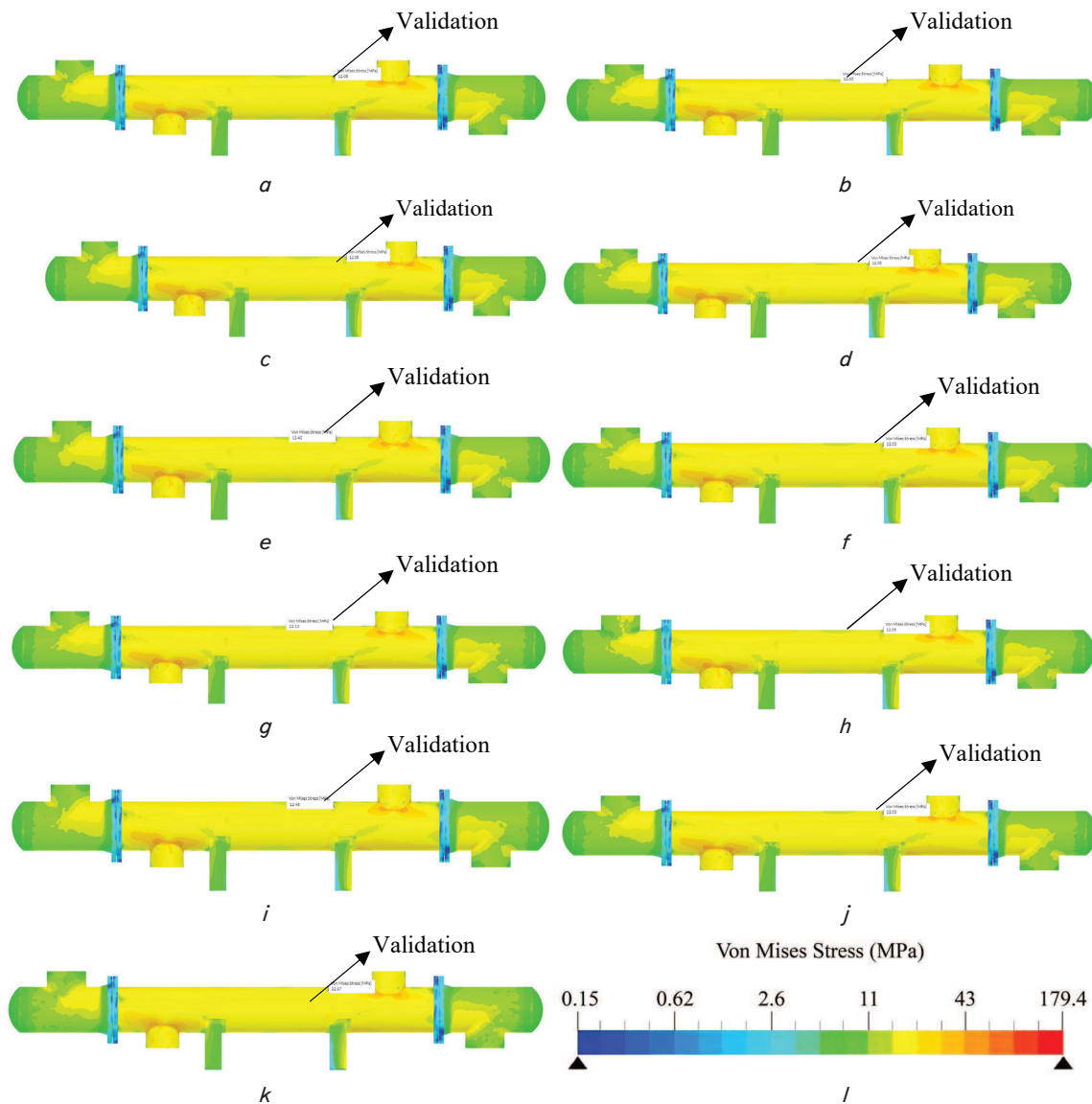

Fig. 7. Von Mises stress validation points by SimScale, tube thickness variations: a – 0.5 mm; b – 0.6 mm; c – 0.7 mm; d – 0.8 mm; e – 0.9 mm; f – 1.0 mm; g – 1.1 mm; h – 1.2 mm; i – 1.3 mm; j – 1.4 mm; k – 1.5 mm; l – Von Mises stress scale

The stress distribution on the heat exchanger components can be seen more clearly on the inside of the equipment. Then Fig. 8 shows the stress distribution in the section view of the equipment. The maximum stress value for each heat exchanger component is shown in Table 6, and the average stress is shown in Table 7.

The relationship between tube thickness and heat exchanger component's maximum stress is presented in

Fig. 9. The graph shows that tube thickness will affect the maximum stress of each heat exchanger component. The higher tube thickness causes the maximum stress on the tube component to decrease and vice versa. The tube thickness also affects the stress on shell, head 1, head 2, tubesheet 1, tubesheet 2, baffle 1, baffle 2, tie rod 1, tie rod 2, tie rod 3, and tie rod 4 components, but the value fluctuates.

Table 5

Comparison of Von Mises Stress by SimScale and Manual Calculation

No.	Tube Thickness (mm)	Manual Calculation (MPa)	SimScale (MPa)	Error (%)
1	0.5	12.20	12.08	0.98
2	0.6	12.20	12.03	1.39
3	0.7	12.20	12.25	0.41
4	0.8	12.20	12.08	0.98
5	0.9	12.20	12.42	1.80
6	1.0	12.20	12.03	1.39
7	1.1	12.20	12.13	0.57
8	1.2	12.20	12.05	1.23
9	1.3	12.20	12.48	2.30
10	1.4	12.20	12.03	1.39
11	1.5	12.20	12.57	3.03

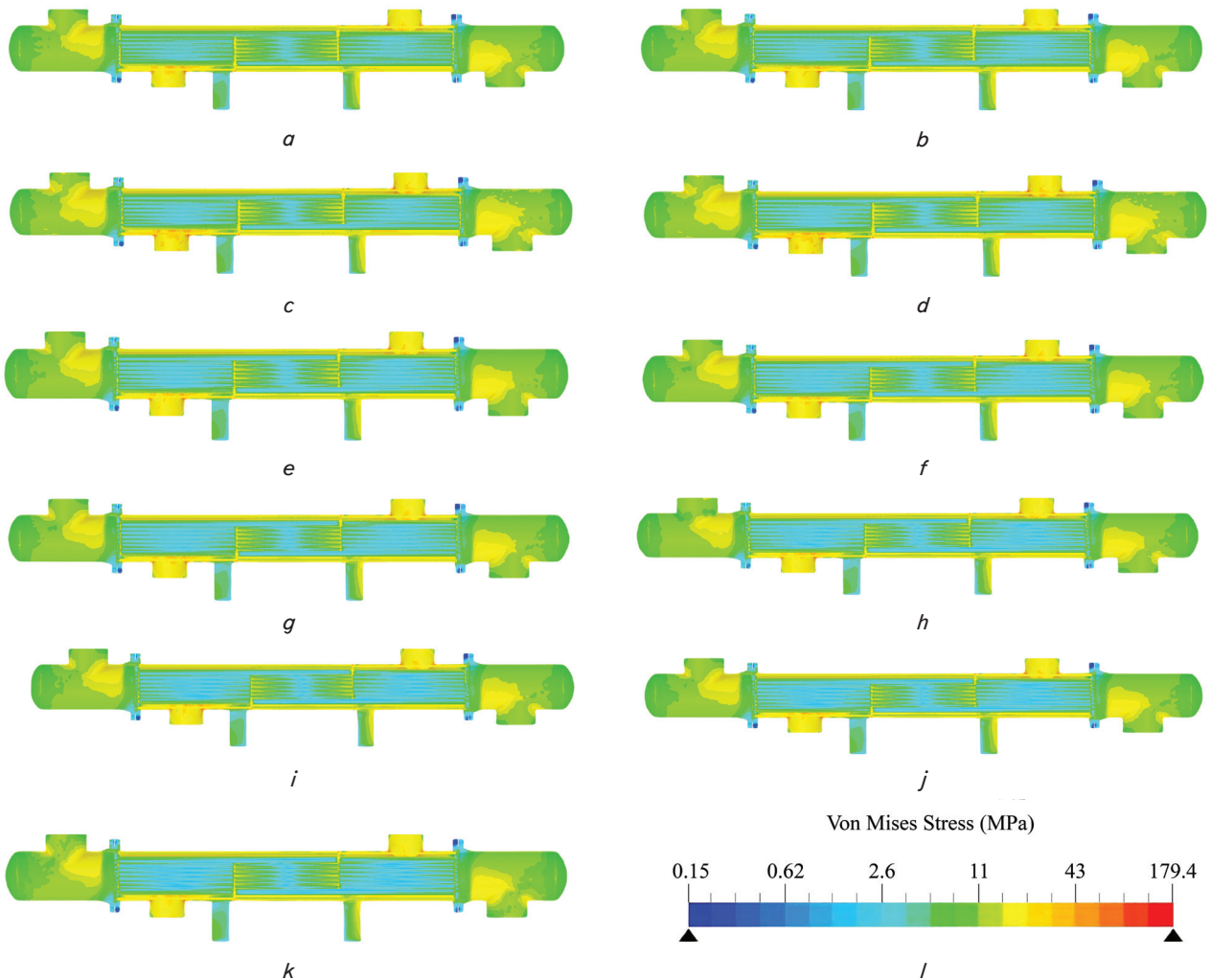

Fig. 8. Von Mises stress distribution on the section view of heat exchanger, tube thickness variations: a – 0.5 mm; b – 0.6 mm; c – 0.7 mm; d – 0.8 mm; e – 0.9 mm; f – 1.0 mm; g – 1.1 mm; h – 1.2 mm; i – 1.3 mm; j – 1.4 mm; k – 1.5 mm; l – Von Mises stress scale

Table 6

Simulation Results of Maximum Stress

		Heat exchanger with tube thickness										
		0.5 mm	0.6 mm	0.7 mm	0.8 mm	0.9 mm	1.0 mm	1.1 mm	1.2 mm	1.3 mm	1.4 mm	1.5 mm
Maximum stress of ($\times 10^6$ Pa)	Tube	179.41	169.95	142.20	133.10	114.10	108.90	83.10	73.50	72.34	58.10	55.20
	Shell	92.34	87.98	94.86	91.65	83.98	91.31	89.68	86.35	96.35	86.28	83.83
	Head 1	30.16	29.51	30.67	28.28	30.76	30.03	29.15	28.99	29.98	29.29	30.22
	Head 2	30.16	29.46	27.44	29.17	27.45	28.69	27.79	24.42	29.52	29.17	28.46
	Tubesheet 1	48.53	57.42	59.36	54.09	66.83	57.02	52.48	51.75	42.55	43.14	50.31
	Tubesheet 2	63.55	58.80	67.87	61.86	54.66	72.07	64.00	66.04	52.97	53.47	58.49
	Baffle 1	113.20	125.00	13.60	168.32	137.97	98.93	110.00	149.48	128.20	145.87	158.36
	Baffle 2	104.80	128.5	152.33	105.60	113.20	121.84	154.98	105.10	136.53	99.43	111.80
	Tie Rod 1	49.27	40.07	56.24	63.50	85.12	51.16	51.90	57.63	46.73	53.86	80.62
	Tie Rod 2	18.77	21.29	17.99	14.20	15.80	16.82	19.82	19.15	18.19	21.94	14.90
	Tie Rod 3	17.75	32.08	23.67	25.42	30.34	30.46	29.79	25.20	21.48	22.71	32.47
	Tie Rod 4	53.19	53.19	53.19	53.19	53.19	53.19	53.19	53.19	53.19	53.19	53.19

Table 7

Simulation Results of Average Stress

		Heat exchanger with tube thickness										
		0.5 mm	0.6 mm	0.7 mm	0.8 mm	0.9 mm	1.0 mm	1.1 mm	1.2 mm	1.3 mm	1.4 mm	1.5 mm
Average stress of ($\times 10^6$ Pa)	Tube	6.82	6.59	6.16	5.88	5.54	5.28	5.16	5.10	5.00	4.76	4.72
	Shell	20.71	20.70	20.67	20.66	20.64	20.59	20.57	20.56	20.54	20.48	20.47
	Head 1	9.37	9.38	9.38	9.36	9.38	9.37	9.37	9.40	9.37	9.38	9.39
	Head 2	9.48	9.44	9.44	9.44	9.44	9.44	9.45	8.96	9.44	9.43	9.46
	Tubesheet 1	3.89	3.89	3.89	3.89	3.89	3.89	3.89	3.89	3.89	3.89	3.89
	Tubesheet 2	4.63	4.65	4.61	4.62	4.69	4.69	4.70	4.74	4.70	4.79	4.66
	Baffle 1	13.44	13.81	14.00	14.35	14.35	14.85	15.10	15.20	15.55	15.53	15.76
	Baffle 2	13.42	13.39	13.72	13.87	14.22	14.36	14.51	14.66	14.65	14.89	14.98
	Tie Rod 1	17.82	17.64	17.88	17.62	17.60	17.69	17.28	17.40	17.18	17.27	17.19
	Tie Rod 2	1.21	1.24	1.26	1.22	1.21	1.25	1.22	1.32	1.22	1.19	1.19
	Tie Rod 3	1.23	1.31	1.31	1.25	1.28	1.31	1.27	1.32	1.25	1.20	1.23
	Tie Rod 4	16.89	17.00	16.67	16.58	16.54	16.37	16.53	16.61	15.98	16.11	16.36

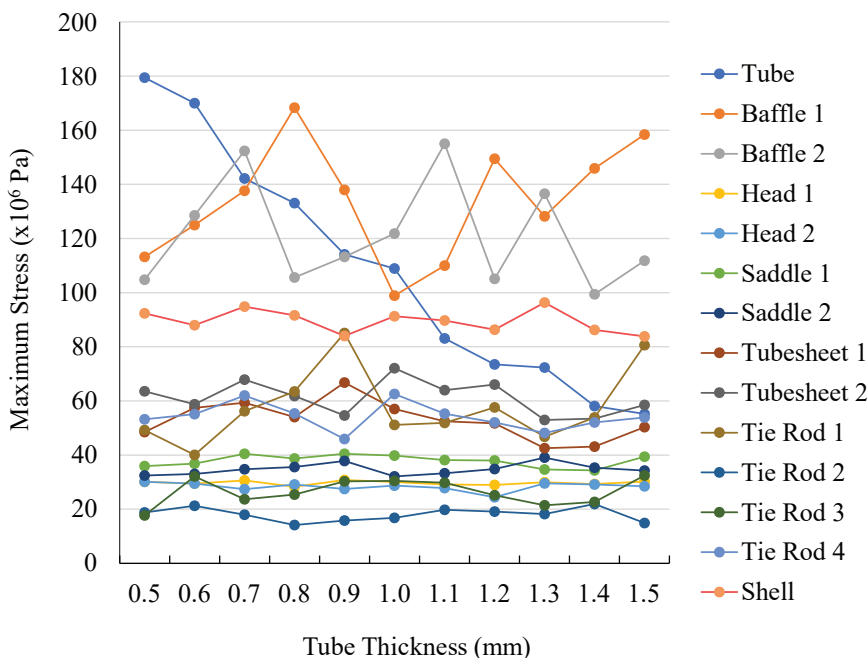

Fig. 9. Maximum stress on heat exchanger components

The relationship between tube thickness and the average stress of heat exchanger components is presented in Fig. 10. The graph shows that the tube thickness will affect the average stress of each heat exchanger component. The higher tube thickness causes the average stress on the tube and shell component to decrease, while baffle 1 and baffle 2 components increase. Tube thickness also affects the average stress on the head, tubesheet, and tie rod components, but the value fluctuates.

From Fig. 10, it is shown that the highest of average stress is shell, while the lowest of average stress is tie rod 3. These components have a fluctuating trend. The other components, which have a fluctuating trend are head, tubesheet, and tie rod. On the other hand, if the tube thickness increases, the average stress of baffle 1 and baffle 2 will also increase, but the average stress of the tube and shell will decrease.

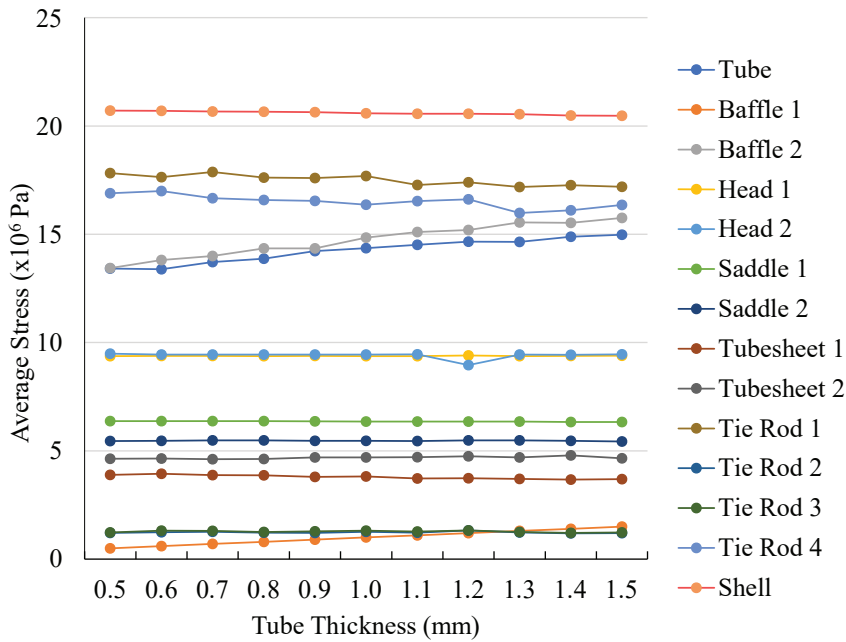

Fig. 10. Average stress on heat exchanger component

5. 4. Indicators of heat exchanger effectiveness

The percentage decrease in heat exchanger effectiveness is presented in Table 8. The heat exchanger effectiveness average value decreased by 0.37 % for each 0.1 mm increase in tube thickness.

Table 8
Percentage of Heat Exchanger Effectiveness Decreasing

No.	Tube Thickness (mm)	Heat Exchanger Effectiveness (ϵ -NTU)	Percentage (%)
1	0.5	0.969	0.00
2	0.6	0.958	1.14
3	0.7	0.955	0.31
4	0.8	0.954	0.10
5	0.9	0.952	0.21
6	1.0	0.948	0.42
7	1.1	0.947	0.11
8	1.2	0.945	0.21
9	1.3	0.942	0.32
10	1.4	0.938	0.42
11	1.5	0.931	0.75

Besides affecting the heat transfer efficiency, tube thickness variations also affect the pressure drop of the hot fluid. The percentage increase in hot fluid pressure drop is presented in Table 9. The average hot fluid pressure drop increased by 4.26 % for each 0.1 mm increase in tube thickness.

The heat exchanger components' design is conducted by the TEMA standard, and these components have extra safety in stress. Table 10 shows the oversdesign level of the heat exchanger components. The oversdesign can be calculated using equation (8).

Table 10 shows that all of the heat exchanger components have a relatively high value of oversdesign. The highest oversdesign value was found in the tie rod 2 compo-

nent, namely 8,384 %, while the lowest oversdesign value was found in the shell component, namely 400 %. In addition, the increase of tube thickness will increase the oversdesign of this component, and the percentage of oversdesign is 3.64 % per 0.1 mm.

Table 9
Percentage of Hot Fluid Pressure Drop Increasing

No.	Tube Thickness (mm)	Pressure Drop (Pa)	Percentage
1	0.5	203	0.00 %
2	0.6	208	2.46 %
3	0.7	222	6.73 %
4	0.8	231	4.05 %
5	0.9	242	4.76 %
6	1.0	253	4.54 %
7	1.1	263	3.95 %
8	1.2	275	4.56 %
9	1.3	288	4.72 %
10	1.4	303	5.20 %
11	1.5	321	5.94 %

Table 10

Oversdesign of Heat Exchanger Components

No.	Component	Allowable Stress (Pa)	Average Stress (Pa)	Oversdesign (%)
1	Tube 0.5 mm	102.5×10 ⁶	6.8×10 ⁶	1414
2	Tube 0.6 mm	102.5×10 ⁶	6.5×10 ⁶	1484
3	Tube 0.7 mm	102.5×10 ⁶	6.2×10 ⁶	1561
4	Tube 0.8 mm	102.5×10 ⁶	5.9×10 ⁶	1645
5	Tube 0.9 mm	102.5×10 ⁶	5.5×10 ⁶	1772
6	Tube 1.0 mm	102.5×10 ⁶	5.3×10 ⁶	1843
7	Tube 1.1 mm	102.5×10 ⁶	5.2×10 ⁶	1880
8	Tube 1.2 mm	102.5×10 ⁶	5.1×10 ⁶	1880
9	Tube 1.3 mm	102.5×10 ⁶	5.0×10 ⁶	1960
10	Tube 1.4 mm	102.5×10 ⁶	4.8×10 ⁶	2045
11	Tube 1.5 mm	102.5×10 ⁶	4.7×10 ⁶	2091
12	Shell	102.5×10 ⁶	20.6×10 ⁶	400
13	Head 1	102.5×10 ⁶	9.4×10 ⁶	995
14	Head 2	102.5×10 ⁶	9.4×10 ⁶	995
15	Tubesheet 1	102.5×10 ⁶	3.8×10 ⁶	2610
16	Tubesheet 2	102.5×10 ⁶	4.7×10 ⁶	2091
17	Baffle 1	102.5×10 ⁶	14.7×10 ⁶	600
18	Baffle 2	102.5×10 ⁶	14.2×10 ⁶	625
19	Tie rod 1	102.5×10 ⁶	17.5×10 ⁶	488
20	Tie rod 2	102.5×10 ⁶	1.2×10 ⁶	8483
21	Tie rod 3	102.5×10 ⁶	1.3×10 ⁶	7823
22	Tie rod 4	102.5×10 ⁶	16.5×10 ⁶	524
23	Saddle 1	102.5×10 ⁶	6.4×10 ⁶	1509
24	Saddle 2	102.5×10 ⁶	5.5×10 ⁶	1772

6. Discussion of experimental results

The results of heat distribution simulation can be used to calculate the heat transfer effectiveness more accurately without manufacturing the heat exchanger to reduce costs and save time. The temperature of the output of hot fluid is a variable in equation (1). This study shows that an increase of 0.1 mm in tube thickness will reduce the heat transfer effectiveness by 0.37 %. Meanwhile, in [13], the heat exchanger effectiveness decreased by 0.25 % for a 0.6 mm increase in tube thickness, and in [14], the heat exchanger effectiveness decreased by 6.45 % for a 0.5 mm increase in tube thickness. Besides, the increase of tube thickness also decreases the pressure drop in the hot fluid. In [13], the pressure drop increased by 0.15 % for each 0.6 mm increase in tube thickness. In [26], the pressure drop rises by 3.96 % for each 3 mm increase in tube thickness. The results of this study differ from the works [13, 14] and [26] because the geometric dimensions under investigation are different (tube length, tube thickness, and tube diameter) and different fluids (fluid properties and fluid velocity). The increase in the hot fluid pressure drop value is due to the increased fluid velocity in equation (2). This speed affects the Reynolds number and fluid friction factor of the hot fluid. Apart from affecting the heat transfer effectiveness and pressure drop, the increase in tube thickness also affects the overdesign of these components. A 0.1 mm increase in tube thickness affects the overdesign of the tube 3.64 %. Therefore, the variations of tube thickness, heat transfer, pressure drop, and overdesign of the tube have a relationship that can be an indicator of designing a heat exchanger.

On the other hand, all components in this study have a relatively large overdesign value. This is shown from the stress analysis on the equipment. The relatively large overdesign value can affect the costs required in the manufacturing process. Further research needs to assess the optimum dimensions by reducing the heat exchanger components' thickness so the overdesign can be reduced and obtaining the expected heat transfer effectiveness and pressure drop values.

7. Conclusions

1. The effectiveness of heat exchangers in exchanging heat is influenced by tube dimensions changing. With the increasing thickness of the tube used, the heat exchanger effectiveness in exchanging heat will decrease, and vice versa. The average decreasing percentage of heat transfer effectiveness is 0.37 % per 0.1 mm of increasing tube thickness.

2. Changes in the dimensions of the tube also influence the pressure drop on the heat exchanger. The effect resulting from the change in sizes is the increasing pressure drop generated and the increase in tube thickness. The rising average percentage of pressure drop is 4.26 % per 0.1 mm of increasing tube thickness.

3. Changes in tube thickness also affect the stress that occurs on each component of the heat exchanger. This change will affect the maximum and average stresses. The maximum stresses and the average stresses that occur have a fluctuating trend. The maximum stress on each heat exchanger component with variations in tube thickness (0.5 mm to 1.5 mm) is still safe because the maximum stress is still below the yield stress. On the other hand, the average stress on the heat exchanger components is relatively far below the yield stress, or it can be called overdesign. The average decreasing percentage of overdesign is 3.64 % per 0.1 mm of increasing tube thickness.

4. The tube thickness variations affect the heat transfer effectiveness, pressure drop, and overdesign of the tube. The value of these can be used to indicate the heat transfer effectiveness of the heat exchanger. The heat exchanger, which needs to increase 0.37 % of transfer effectiveness, the dimension of tube thickness, has to decrease 0.1 mm.

Acknowledgments

This work was supported by a research grant "Collaboration Research" by Universitas Muhammadiyah Yogyakarta.

Reference

1. Sekulic, D. P. (1990). A reconsideration of the definition of a heat exchanger. *International Journal of Heat and Mass Transfer*, 33 (12), 2748–2750. doi: [https://doi.org/10.1016/0017-9310\(90\)90209-d](https://doi.org/10.1016/0017-9310(90)90209-d)
2. Qiu, B., Du, B., Huang, C., Chen, W., Yan, J., Wang, B. (2021). The numerical simulation of the flow distribution and flow-induced vibration analysis for intermediate heat exchanger in a pool-type fast breeder reactor. *Progress in Nuclear Energy*, 131, 103605. doi: <https://doi.org/10.1016/j.pnucene.2020.103605>
3. Prasad, A. K., Anand, K. (2020). Design & Analysis of Shell & Tube Type Heat Exchanger. *International Journal of Engineering Research & Technology (IJERT)*, 9 (01), 524–539 doi: <https://doi.org/10.17577/ijertv9is010215>
4. Shirode, K. D., Rane, S. B., Naik, Y. (2013). Comparison of Design and Analysis of Tube sheet Thickness by Using UHX Code of ASME and TEMA Standard. *International Journal of Mechanical Engineering and Technology*, 4 (4), 105–117. Available at: <http://www.iaeme.com/MasterAdmin/UploadFolder/COMPARISON%20OF%20DESIGN%20AND%20ANALYSIS%20OF%20TUBE%20SHEET%20THICKNESS%20BY%20USING%20UHX%20CODE-2/COMPARISON%20OF%20DESIGN%20AND%20ANALYSIS%20OF%20TUBE%20SHEET%20THICKNESS%20BY%20USING%20UHX%20CODE-2.pdf>
5. Ozden, E., Tari, I. (2010). Shell side CFD analysis of a small shell-and-tube heat exchanger. *Energy Conversion and Management*, 51 (5), 1004–1014. doi: <https://doi.org/10.1016/j.enconman.2009.12.003>
6. Mizutani, F. T., Pessoa, F. L. P., Queiroz, E. M., Hauan, S., Grossmann, I. E. (2003). Mathematical Programming Model for Heat-Exchanger Network Synthesis Including Detailed Heat-Exchanger Designs. 2. Network Synthesis. *Industrial & Engineering Chemistry Research*, 42 (17), 4019–4027. doi: <https://doi.org/10.1021/ie020965m>
7. Hasan, M. I., Rageb, A. A., Yaghoubi, M., Homayoni, H. (2009). Influence of channel geometry on the performance of a counter flow microchannel heat exchanger. *International Journal of Thermal Sciences*, 48 (8), 1607–1618. doi: <https://doi.org/10.1016/j.ijthermalsci.2009.01.004>

8. Silaipillayarputhur, K., Khurshid, H. (2019). The Design of Shell and Tube Heat Exchangers - A Review. *International Journal of Mechanical and Production Engineering Research and Development*, 9 (1), 87–102. doi: <https://doi.org/10.24247/ijmperdfeb201910>
9. Kapale, U. C., Chand, S. (2006). Modeling for shell-side pressure drop for liquid flow in shell-and-tube heat exchanger. *International Journal of Heat and Mass Transfer*, 49 (3-4), 601–610. doi: <https://doi.org/10.1016/j.ijheatmasstransfer.2005.08.022>
10. Xu, S., Wang, W. (2013). Numerical investigation on weld residual stresses in tube to tube sheet joint of a heat exchanger. *International Journal of Pressure Vessels and Piping*, 101, 37–44. doi: <https://doi.org/10.1016/j.ijpvp.2012.10.004>
11. Li, F., Xing, J., Liu, Y. (2011). Thermal Analysis and Stress Analysis of the Heat-Exchange Pipe Based on ANSYS. 2011 Fourth International Conference on Information and Computing, 283–285. doi: <https://doi.org/10.1109/ici.2011.137>
12. Li, Z.-H., Jiang, P.-X., Zhao, C.-R., Zhang, Y. (2010). Experimental investigation of convection heat transfer of CO₂ at supercritical pressures in a vertical circular tube. *Experimental Thermal and Fluid Science*, 34 (8), 1162–1171. doi: <https://doi.org/10.1016/j.exptthermflusc.2010.04.005>
13. Erek, A., Özerdem, B., Bilir, L., İlken, Z. (2005). Effect of geometrical parameters on heat transfer and pressure drop characteristics of plate fin and tube heat exchangers. *Applied Thermal Engineering*, 25 (14-15), 2421–2431. doi: <https://doi.org/10.1016/j.applthermaleng.2004.12.019>
14. Saberimoghaddam, A., Abadi, M. M. B. R. (2017). Parasitic Effect of Tube Wall Longitudinal Heat Conduction on Cryogenic Gas Temperature. *Iranian Journal of Chemical Engineering (IJChE)*, 14 (1), 15–25.
15. Noh, J.-H., Kwak, D.-B., Yook, S.-J. (2017). Effects of wall thickness and material property on inverse heat conduction analysis of a hollow cylindrical tube. *Inverse Problems in Science and Engineering*, 26 (9), 1305–1325. doi: <https://doi.org/10.1080/17415977.2017.1400027>
16. Hu, W., Jia, P., Nie, J., Gao, Y., Zhang, Q. (2018). A Fast Prediction Model for Heat Transfer of Hot-Wall Heat Exchanger Based on Analytical Solution. *Applied Sciences*, 9 (1), 72. doi: <https://doi.org/10.3390/app9010072>
17. Ravagnani, M. A. S. S., Caballero, J. A. (2007). A MINLP Model for the Rigorous Design of Shell and Tube Heat Exchangers Using the Tema Standards. *Chemical Engineering Research and Design*, 85 (10), 1423–1435. doi: [https://doi.org/10.1016/s0263-8762\(07\)73182-9](https://doi.org/10.1016/s0263-8762(07)73182-9)
18. Farr, J. R., Jawad, M. H. (2010). *Guidebook for the Design of ASME Section VIII Pressure Vessels*. ASME Press, 344. doi: <https://doi.org/10.1115/1.859520>
19. Liang, Q. Q. (2005). *Performance-Based Optimization of Structures. Theory and Applications*. CRC Press. doi: <https://doi.org/10.1201/9781482265521>
20. Bichkar, P., Dandgaval, O., Dalvi, P., Godase, R., Dey, T. (2018). Study of Shell and Tube Heat Exchanger with the Effect of Types of Baffles. *Procedia Manufacturing*, 20, 195–200. doi: <https://doi.org/10.1016/j.promfg.2018.02.028>
21. Schmelter, S., Olbrich, M., Schmeyer, E., B r, M. (2020). Numerical simulation, validation, and analysis of two-phase slug flow in large horizontal pipes. *Flow Measurement and Instrumentation*, 73, 101722. doi: <https://doi.org/10.1016/j.flowmeasinst.2020.101722>
22. Franck, H., Franck, D. (2012). *Forensic engineering fundamentals*. CRC Press, 487. doi: <https://doi.org/10.1201/b13690>
23. Bergman, T. L., Lavine, A. S., Incropera, F. P., Dewitt, D. P. (2011). *Fundamentals of Heat and Mass Transfer*. Wiley, 1080.
24. Khurmi, R., Gupta, J. (2005). *A Textbook of Machine design*. Ram Naga: Eurasia Publishing House (PVT.) LTD.
25. Beyers, W. A., Zapke, A., Venter, G. (2015). Improved Cover Type Header Box Design Procedure. *R & D Journal of the South African Institution of Mechanical Engineering*, 31, 76–85.
26. Alkhakani, A. J., Adam, N. M., Hairuddin, A. A., Alsabahi, H. K. (2015). Effect of Tube Thickness for Shell and Tube Heat Exchanger in Portable Solar Water Distiller. *International Journal of Engineering Research & Technology (IJERT)*, 4 (11), 37–42.