



THE DETERMINANT OF SHARIA BANKING PERFORMANCE THROUGH FINANCING TO DEPOSIT RATIO AS MODERATOR

¹Ervina Rahmadila and ²Slamet Haryono

UIN Sunan Kalijaga, Department Magister Sharia Economics

slamet.haryono@uin-suka.ac.id

ABSTRACT

The most concern for investors in both bank and non-bank institutions is the quality of the accounting information provided. Financial statements are considered important because they can determine decisions for each investor. Supporting performance in this era of globalization is accounting information system. Sharia banking's good performance is supported by several factors including capital or operational ratios such as CAR, BOPO, and NPF. This study used pooled least square method with panel data in the period 2010 to 2018. The results showed that together the results showed that the variables NPF, CAR, BOPO have a positive and insignificant influence on ROA.

Keywords: Sharia Banking Performance; Ratio; ROA

Article History

Received : 06 July 2021

Revised : 19 December 2021

Accepted : 24 December 2021

Available online : 31 December 2021

<https://doi.org/10.14421/EkBis.2021.5.2.1331>

INTRODUCTION

Today, Indonesian Islamic financial institutions, especially Islamic banking, are experiencing rapid growth. According to Statistical Data from the Financial Services Authority (OJK), in January 2019 total Islamic banking assets amounted to Rp 425,150.42 billion. The composition of Islamic banking assets consists of assets of Islamic Commercial Banks (BUS) of 67.13%, Sharia Business Units (UUS) of 30.29%, and the remaining Sharia People's Financing Banks (BPRS) of 2.58%. In this case, Islamic commercial banks have the largest composition in national Islamic banking assets, amounting to Rp285.397 billion. The growth of assets in Islamic commercial banks was influenced by the conversion of the Aceh Regional Development Bank (BPD) to Aceh Sharia Bank in September 2016.

One of the regulations that must be met by financial institutions is the regulation on the publication of financial statements. The thing that is most noticed by investors in both bank and non-bank institutions is the quality of the accounting information provided. Financial statements are considered important because they can determine decisions for each investor. Investors can ignore accounting information if the costs used exceed the benefits. The challenge in outlining the awareness and acquisition costs of other frictions is that the material set of investors' information is usually not serviceable (Blankespoor et al., 2019).

Supporting performance in this era of globalization is the accounting information system. The application of accounting system technology can provide added value for users in the form of providing various financial information for planning, controlling, and decision-making activities which ultimately have an impact on improving the performance of managers or administrators. This new accounting technology can help in embedding sustainability in organizations. The Global Reporting Initiative (GRI) describes sustainability reporting as the voluntary disclosure of information about the economic, social, and environmental impacts of an organization's operations (Farooq & de Villiers, 2019).

The good performance of Islamic banking is supported by several factors including ratios related to capital or operations such as CAR, BOPO, and NPF. CAR (Capital Adequacy Ratio) is a ratio related to capital which will affect the ability of a bank to efficiently carry out its activities. If the capital owned by a bank is able to absorb unexpected or unavoidable losses, then the bank has the opportunity to carry out its operational activities efficiently. Thus, banks also have high expectations to increase their wealth (Nanda et al, 2019). Return on Assets (ROA) is used as a performance measure because ROA measures the ability of bank management to obtain overall profits (Nanda et al., 2019).

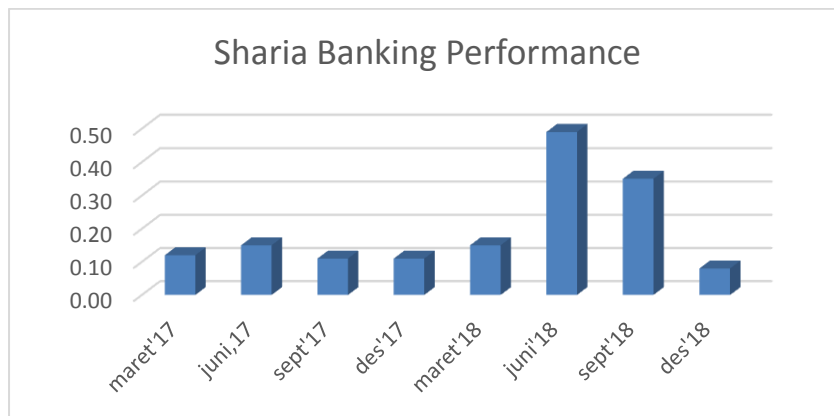

Source: OJK (2019)

Figure 1
Sharia Banking Performance

This research was conducted at Islamic banking financial institutions that have been legalized as Islamic commercial banks. Researchers examine the performance of Islamic banking which is influenced by variables related to accounting quality. The approach used is a quantitative approach. The purpose of this study is to obtain an overview and information about the performance of Islamic banking through the quality of accounting information provided. There have been many previous studies examining management accounting information and strategy have developed into a productive field of research. However, there is still a lack of research on accounting information on Islamic banking financial institutions.

LITERATURE REVIEW

Several preceding research associated with the subjects raised within the take a look at are an crucial reference in order that researchers acquire preceding research which can be applicable to this studies. The following are a few preceding research associated with this studies. Blankespoor et al. (2019) state that is prompted through the idea that accounting statistics is cost applicable and buyers intention to maximise risk-adjusted returns. Meanwhile, researchers count on buyers to apply accounting statistics in buying and selling decisions. However, buyers can forget about accounting statistics if the expenses used exceed the benefits. The effects confirmed that there had been doubts and questions on policies geared toward buyers to growth focus and get admission to to accounting statistics. Farooq & de Villiers (2019) researched on Understanding How Managers Institutionalise Sustainability Reporting; Evidence from Australia and New Zealand. In this take a look at, the researcher attempts to analyze how SRMs institutionalize sustainability reporting (inclusive of how they perform a

materiality evaluation i.e. choosing topics/problems for disclosure). The consequences confirmed that ten motives had been recognized for now no longer disclosing cloth subjects that had been vital however now no longer constrained to legitimacy motives. At the theoretical degree this take a look at offers 4 observations that have to be taken into consideration in inspecting types of paintings in institutions. Xu et al. (2017) with the identify Accruals Quality, Underwriter Reputation and Corporate Bond Underpricing; Evidence from China. Many research have mentioned and documented that records asymmetry idea can provide an explanation for the underpricing of a company's preliminary public offering (IPO). However, even though there's a good sized frame of studies at the effect of records asymmetry on IPO underpricing, maximum studies has targeted completely at the fairness market. In addition, many research documenting that reliable underwriters can sign and certify the nice of the issuer's economic records throughout an IPO display that there's a poor dating among underwriter popularity and underpricing regular with the function of underwriter certification. The consequences display that accrual causality is negatively related to the importance of bond underpricing and the effect of low accrual causality on underpricing is in part offset with the aid of using hiring a main underwriter.

Barth et al. (2017) researched the Evolution in Value Relevance of Accounting Information the usage of descriptive statistical techniques and the variables used have been price (P), blended price relevance (OOSR), accounting price relevance (VR), the applicable accounting quantity (NUMVR). The effects display that the Researcher assessed the evolution withinside the price relevance of every quantity and discovered will increase mainly for quantities associated with intangible assets, boom opportunities, and opportunity overall performance measures which are vital withinside the new economy. Kim et al. (2017) with the identify A Framework for Analytics and Simulation of Accounting Information System; A Petri internet Modeling Primer. The history of this observe is that researchers discovered facts and additionally subject data approximately device flowcharts which have been utilized in accounting and auditing because the Nineteen Sixties to version file float in accounting data systems (AIS).

Figlioli et al. (2020) have a look at In Search for Good News; The Relationship Between Accounting Information, Bounded Rationality, and Hard-to-price Stocks. The history of this have a look at is primarily based totally on numerous factors, particularly the life of buyers who're liable to blunders and bias in valuation for shares which are tough to appreciate, the Information Uncertainty Effect (IUE) produces anomalies in inventory prices, IFRS will increase the relevance of accounting data that may weaken the IUE. In addition, the researchers observed that the coolest information become related to the eye impact of the mass of buyers, a bigger applause than the inventory fee diagnosed for hard-to-fee shares. The outcomes of the have a look at reap proof of the way

buyers who're taken into consideration to were associated with rationality have an effect on the dynamics of inventory fee formation. In addition, the outcomes of the have a look at additionally display that the marketplace price of stocks has a tendency now no longer to mirror accounting data for shares which are tough to appreciate. In this case, accounting data is valued step by step over time.

Massicotte & Henri (2021) with the name *The Use of Management Accounting Information via way of means of Boards of Directors to Oversee Strategy Implementation*. This studies is prompted via way of means of the various preceding research that have a look at control accounting records and method has advanced right into a efficient studies field. However, nearly no studies has tested the usage of MAI withinside the context of forums of administrators that range from the agency as a whole. The board of administrators itself consists of govt and impartial contributors whose understanding of the agency's sports and whose distance from everyday operations varies widely. The effects confirmed that the validity and reliability of the device changed into evaluated and mentioned the use of a rigorous multi-approach incorporated technique that blanketed a literature review, exploratory interviews, session of specialists in control accounting and governance, and survey records gathered from 3 samples of forums of administrators.

Essa et al. (2018) with the name *Your Gain My Pain? The Effects of Accounting Information in Uncertain Negotiations*. The history of this studies is that there are levels of negotiation which might be taken into consideration vital for this motive due to the fact the negotiation technique units the degree for destiny conduct and may play a position withinside the results completed with the aid of using partners. While the good sized literature on negotiation studies identifies situations that affect negotiator conduct and results, preceding accounting research have in particular taken into consideration the capability of accounting statistics in stimulating cooperative negotiating conduct. In this study, we experimentally look at buyer-dealer negotiations to research how price uncertainty inherent in transactions interacts with accounting statistics in influencing negotiation conduct and results. Following preceding research in experimental economics, we studied a selected shape of uncertainty, particularly uncertainty in negotiator payments. The effects endorse that price uncertainty can also additionally lessen negotiators' use of relative to distributive tactics, which in flip has a terrible effect on mutual profit. However, more suitable accounting statistics attenuates the terrible effect of price uncertainty on conduct, lowering the terrible effect on shared profits.

Sharia Banking

In general, banks are establishments that perform 3 principal capabilities, particularly accepting deposits, lending cash, and imparting remittance services. In the monetary records of Muslims, financing executed with sharia-compliant contracts has been a part of the subculture of Muslims because the time of the Prophet Muhammad. Practices which include accepting deposits, lending cash for intake and commercial enterprise purposes, and being profitable transfers, had been not unusual place because the time of the Prophet Muhammad. Thus, the principle capabilities of present day banking, particularly accepting deposits, channeling budget, and shifting budget have come to be an inseparable a part of the lives of Muslims, even because the time of Prophet Muhammad (Nanda et al, 2018). The improvement of Islamic banking have to additionally be supported through human assets, each in phrases of exceptional and quantity. However, the truth suggests that there are nonetheless many assets who've been concerned in Islamic establishments that don't have instructional or sensible enjoy in Islamic banking. Of course, this situation appreciably impacts the productiveness and professionalism of Islamic banking itself. This is what in reality desires to get the eye of all of us, particularly printing human assets who're capable of exercise sharia economics in all traces due to the fact an awesome device can't paintings if it isn't supported through proper human assets.

Financial Report

Statements Financial statements are periodic reviews organized in step with commonly well-known accounting concepts concerning the monetary repute of individuals, institutions or commercial enterprise groups including stability sheets, profits statements, and statements of modifications in owner's equity. Bank monetary statements are similar to organization monetary statements. The financial institution stability sheet suggests a photograph of a financial institution's monetary role at a sure time. The profits assertion suggests the outcomes of the sports or operations of a financial institution throughout a sure period. The assertion of modifications in monetary role suggests wherein the financial institution's reassets of budget come from and wherein the budget are channeled. This file is compiled from the stability sheet on the time of periods (dates) and the profits assertion for the suggested period (Kustono & Adi Nanggala, 2020).

Return on Non Assets (ROA)

ROA is a company's financial ratio related to profit potential, measuring the company's strength to generate profits or profits at the level of income, assets and specific capital. In another sense ROA is a form of profitability ratio to measure the company's ability to generate profits by using the total existing assets and after

the costs of capital (the cost of money is used to fund assets) are excluded from the analysis. The formula for ROA is (Lévy et al., 2018):

$$ROA = \frac{\text{Earning After Tax (EAT)}}{\text{Shareholder's Equity}} \times 100$$

Finance to Deposit Ratio (FDR)

Finance to Deposit Ratio (FDR) is used to assess the liquidity of a bank by dividing the amount of credit by the amount of funds. FDR is a ratio that shows the ability of a bank to provide funds to debtors with the capital owned by the bank as well as funds that can be collected from the public. If the bank can channel all the funds raised, it will be profitable, but this is related to the risk if at any time the owner of the funds withdraws his funds or the user of the funds cannot return the funds he borrowed. On the other hand, if the bank does not channel its funds, the bank will also be exposed to risk because it will lose the opportunity to make a profit. The minimum loan limit provided by the bank is 80% and the maximum is 110%. The formula for FDR is (Lévy et al., 2018):

$$FDR = \frac{\text{Credit}}{\text{Third Party Funding}} \times 100$$

Non-Performing Financing (NPF)

According to the Indonesian dictionary, *Non-Performing Loans (NPL)* or *Non-Performing Financing (NPF)* are non-performing loans consisting of loans that are classified as substandard, doubtful, and bad. NPF is like the NPL of conventional banks, which arise due to problems that occur in the financing approval process within the bank, or after the financing is given. However, NPF and NPL occur on different systems. The Islamic banking system has fundamental factors that can prevent the emergence of NPF from expanding, but the conventional banking system provides a greater opportunity for the occurrence of NPLs. The formula for *Non-Performing Financing (NPF)* is (Lévy et al., 2018):

$$NPF = \frac{\text{TOTAL NPF}}{\text{TOTAL CREDIT}} \times 100\%$$

Capital Adequacy Ratio (CAR)

CAR is a bank's performance ratio used to measure the adequacy of capital owned by a bank to support assets that contain or generate risk, such as loans. CAR is measured from the ratio between bank capital and risk-weighted assets (RWA) (Lévy et al., 2018).

$$CAR = \frac{\text{Bank Capital}}{\text{TOTAL ATMR}} \times 100\%$$

Operating Efficiency Ratio (BOPO)

BOPO is a ratio used to measure the level of efficiency and ability of a bank in carrying out its operations. According to BI Circular No. 3/30DPNP dated December 14, 2001, BOPO is measured from the comparison between operating costs and operating income (Lévy et al., 2018).

$$BOPO = \frac{\text{Operational Cost}}{\text{Operational Earning}} \times 100\%$$

Research hypotheses are presented as a source of research questions and especially the basis of research to be solved. The following are the hypotheses of this research based on theory and previous research:

- H₁: The NPF variable (X1) has a negative effect on ROA (Y)
- H₂: The CAR variable (X2) has a positive effect on ROA (Y)
- H₃: The BOPO variable (X3) has an effect negative on ROA (Y)
- H₄: The FDR variable (Z) has a positive effect on ROA (Y)

In H₄ it is stated that the FDR variable is a moderating variable that can strengthen or weaken the influence of the size of third party funds on Islamic banking performance. It can be explained that the higher the FDR in Islamic banks, the better the bank's ability, meaning that the bank can manage the intermediation function optimally.

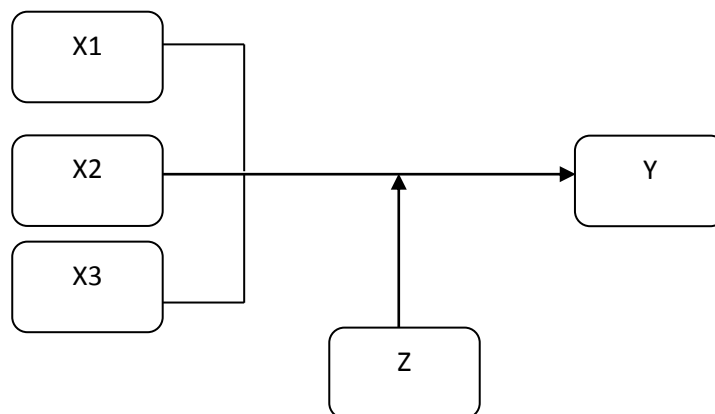

Source: Data processed, 2020

Figure 2.
Conceptual Model

METHODOLOGY

Based on the type of data, this research is a quantitative research, namely research whose data is in the form of numbers. The analytical tool in this research is panel data regression analysis which is processed using the program EViews 9.0. Data panel is a composite of data time series (time series) and data cross-sectional (individual). The data used by the researcher is quarterly data from 2010 to 2018 using data from the official website of Islamic banking and the Financial Services Authority. In this study, panel data regression analysis was used because in panel data regression analysis has several advantages, including being able to provide more data, resulting in a degree of freedom greater. As well as being able to overcome problems that arise if there is a problem omitted variable (Davies & Lahiri, 1995). The panel data regression consists of pooled least square (PLS), fixed effect model (FEM), and random effect model (REM). The model equation used is as follows:

$$Y_{it} = \beta_{0i} + \beta_1 NPF_{it} + \beta_2 CAR_{it} + \beta_3 BOPO_{it} + \beta_4 FDR_{it} + \varepsilon_{it} \quad (1)$$

The best model testing to choose between PLS, FEM and REM is done by:

1) *Chow test - Choosing between PLS and FEM*

To find out the best model in panel data testing, it can be done by adding a variable dummy so that it can be seen that the intercept between individuals is different. This test is used to determine whether the panel data regression technique with the method fixed effect is better than the panel data regression using the method common effects or the panel data model without variables dummy by looking at the sum of residuals (RSS).

H_0 : *pooled least square (PLS)*

H_1 : *fixed effect model (FEM)*

2) *Hausman test - Choose between FEM and REM*

After determining the right method between the OLS method and the fixed effect (test Chow) then the test is carried out Hausman to choose the method fixed effect or random effect most appropriate to be used in panel regression. This test is based on the idea that the two models Least Square Dummy Variable (LSDV) in the method fixed effect and the Generalization Least Square (GLS) in the method random effect are efficient while the Ordinary Least Square (OLS) in the method common effects is inefficient in the null hypothesis. The test statistic Hausman follows the statistical distribution Chi-Square with as many degrees of freedom (df) as the number of independent variables.

H_0 : *random effect model (REM)*

H_1 : *fixed effect model (FEM)*

3) *LM BP test - Choosing between PLS and REM*

The lagrange multiplier test is a test to determine the model common effect or random effect most appropriate used in estimating panel data. The test was lagrange multiplier developed by Breusch Pagan, where tested the significance of the model random effect based on the residual value of the method common effect (OLS).

H₀: *pooled least square (PLS)*

H₁: *random effect model (REM)*

RESULT

Based on the results of data processing using the method, the *pooled least square* results show that the NPF and CAR variables have a positive influence, but only the CAR variable is significant. From the test results, the results obtained on the NPF variable with a t-statistic of 1.5 and not significant with a significance value of 0.14. The results of these numbers indicate that NPF has no effect on ROA so that the hypothesis cannot be accepted. This also applies to the CAR variable which has no effect on ROA. The BOPO variable has negative and insignificant test results with a t-statistic number of -2.5 and a significance level of 0.01. This shows that the higher the level of BOPO, the lower the level of ROA. Together (F test) the three variables used have positive and insignificant results on the ROA variable. The FDR variable as a moderator between the independent and dependent variables showed negative and insignificant results. This shows that the moderating variable has no effect on variables Y and X in the study.

Table 1.
Panel Data Test Results

Variable	Coefficient	Std. Error	t-Statistic	Prob.
C	13.39303	7.468751	1.793209	0.0775
X1	0.142261	0.095771	1.485426	0.1422
X2	4.894120	1.908502	2.564377	0.0126
X3	-0.183095	0.071132	-2.574001	0.0123
Z	-0.038044	0.066401	-0.572938	0.5686
ZX	-1.900005	1.290005	-1.478076	0.1441

Source: Output Eviews, 2020

The first hypothesis states that the NPF variable has a negative effect on ROA. NPF is a comparison between non-performing financing and the amount of financing provided. Troubled or stuck financing that starts suddenly with an omen is extremely rare. Banks can detect from the variables that are in arrears on the principal financing and the agreed amount of profit sharing (Vernanda & Widyarti, 2016). NPF reflects financing risk, where the higher the NPF, the worse the quality of financing from Islamic banks. Management of financing in Islamic banks is very necessary because in financing is one of the largest contributors to income in Islamic banks. In addition, if the NPF is small and presented in accounting reports, it will be better in attracting investors to invest in Islamic banks. Previous studies states that the healthier Islamic bank financing will have an effect on obtaining more and more profits. It is strengthened by research from Kusumastuti & Alam (2019) which states that an increase in the number of financing problems in Islamic banks is not always followed by an increase in profit. It can be concluded that the higher the NPF can affect the performance of banks but not significantly, besides that the high NPF can reduce the level of quality of accounting information in banking financial statements and can have an impact on investors' decisions.

The second hypothesis states that the CAR variable has a positive effect on ROA. The main capital of the bank is intended to cover unexpected potential and as a reserve in the event of a crisis. The funds come from various sources, including the government, Bank Indonesia, shareholders or the public. The more funds collected, the more funds will be used as financing for customers and this will also have an impact on increasing ROA. The results of this study indicate that CAR has no effect on ROA. This is due to the phenomenon of bank financial statement data in the study period has increased but ROA has decreased. It is the same with research from Nanda et al. (2019) which shows the results that partially CAR does not have an effect on ROA. So it can be concluded that the rise and fall of CAR in financial statements can affect the level of performance and can also affect the quality of Islamic banking accounting information.

The third hypothesis states that the BOPO variable has a negative effect on ROA. The BOPO variable can be calculated quantitatively using the efficiency ratio. The efficiency ratio is used to measure how efficient the corporation is in using its assets. The results of research from Nanda et al. (2019) state that BOPO has a negative and significant effect on ROA. The results of this study also found that the BOPO variable had a negative and significant effect on ROA. It means that the higher the BOPO, the less good it will be on ROA. Through this ratio it is calculated whether the bank's management has used all of its production factors effectively and efficiently. The results of this study support the findings state that BOPO has a negative and significant effect on *return on assets* (ROA) (Astuti & Husna, 2020; Kusumastuti & Alam, 2019).

The results of data processing from the FDR variable or moderating variable on ROA indicate that these variables have a negative and insignificant effect. This can be explained that the increase in total costs is not always in line with performance in Islamic banking, in fact there is a reverse trend, namely an increase in the number of loans followed by a decrease in sharia banking performance. So it can be captured that the FDR variable has a significant negative effect on ROA. The results of this study are not in line with research from Mursal et al. (2019) which shows that the FDR variable has a negative and significant effect on ROA. This means that the higher the FDR, the lower the company's profit. Thus it can be formulated that FDR has a significant positive effect on ROA. This is in accordance with the results of research from Nurullaili (2016) which states that the FDR ratio has a significant positive effect on ROA.

CONCLUSION

Based at the literature evaluate together with the check effects and panel information processing, it could be concluded that the primary speculation states that the NPF variable has a terrible impact on ROA. NPF is a evaluation among non-appearing financing and the quantity of financing provided. Troubled or caught financing that begins off evolved unexpectedly with an omen is extraordinarily rare. CAR has no impact on ROA. This is because of the phenomenon of financial institution monetary declaration information withinside the look at length has multiplied however ROA has decreased. The BOPO variable has a terrible impact on ROA. The BOPO variable may be calculated quantitatively the usage of the performance ratio. The performance ratio is used to degree how green the employer is in the usage of its assets. The FDR variable or moderating variable on ROA shows that this variable has a terrible and insignificant impact. This may be defined that the boom in general fees isn't usually in keeping with overall performance in Islamic banking, in truth there's a opposite trend, specifically an boom withinside the range of loans accompanied through a lower in sharia banking overall performance. Based at the effects of the look at, the researchers recommend for similarly authors so one can upload different variables which could have an effect on ROA in Islamic banking.

REFERENCES

- Astuti, E. P., & Husna, F. M. (2020). The Effect of Net Interest Margin (NIM) and Operational Costs Operating Income (BOPO) on Return on Assets (RoA) at PT. Bank Rakyat Indonesia, Tbk. *PINISI Discretion Review*, 2(1), 1.
- Barth, M. E., Li, K., & McClure, C. G. (2017). Evolution in Value Relevance of Accounting Information. In *SSRN Electronic Journal*.
- BLANKESPOOR, E., DEHAAN, E., WERTZ, J., & ZHU, C. (2019). Why Do Individual Investors Disregard Accounting Information? The Roles of Information Awareness and Acquisition Costs. *Journal of Accounting Research*, 57(1), 53–84.
- Davies, A., & Lahiri, K. (1995). A new framework for analyzing survey forecasts using three-dimensional panel data. *Journal of Econometrics*, 68(1), 205–227.
- Essa, S. A. G., Dekker, H. C., & Groot, T. L. C. M. (2018). Your gain my pain? The effects of accounting information in uncertain negotiations. *Management Accounting Research*, 41, 20–42.
- Farooq, M. B., & de Villiers, C. (2019). Understanding how managers institutionalise sustainability reporting. *Accounting, Auditing & Accountability Journal*, 32(5), 1240–1269.
- Figlioli, B., Lemes, S., & Lima, F. G. (2020). In search for good news: The relationship between accounting information, bounded rationality and hard-to-value stocks. *Emerging Markets Review*, 44, 100719.
- Kim, R., Gangolly, J., & Elsas, P. (2017). A framework for analytics and simulation of accounting information systems: A Petri net modeling primer. *International Journal of Accounting Information Systems*, 27, 30–54.
- Kustono, A. S., & Adi Nanggala, A. Y. (2020). Preparing quality financial statements at health centers: to explore the role of regional inspectorates and professionalism of accounting personnel. *The Indonesian Accounting Review*, 10(1), 1–12.
- Kusumastuti, W. I., & Alam, A. (2019). Analysis of Impact of CAR, NPF, BOPO on Profitability of Islamic Banks (Year 2015-2017). *Journal of Islamic Economic Laws*, 2(1), 30–59.
- Lévy, A., Ben Bouheni, F., & Ammi, C. (2018). *Financial Management*. John Wiley & Sons, Inc.
- Massicotte, S., & Henri, J.-F. (2021). The use of management accounting information by boards of directors to oversee strategy implementation. *The British Accounting Review*, 53(3), 100953.
- Mursal, M., Darwanis, D., & Ibrahim, R. (2019). What Influences Capital Adequacy Ratio in Islamic Commercial Banks? Evidence from Indonesia.

- Journal of Accounting Research, Organization and Economics*, 2(1), 1–10.
- Nanda, A. S., Hasan, A. F., & Aristyanto, E. (2019). Pengaruh CAR dan BOPO Terhadap ROA pada Bank Syariah pada Tahun 2011-2018. *Perisai : Islamic Banking and Finance Journal*, 3(1), 19–32.
- Nurullaily, S. (2016). Analysis of Influence Financial Ratios on Sharia Banking Performance in Indonesia (Empirical Study at Bank Muamalat Indonesia, Bank Syariah Mandiri, and Bank Mega Syariah). *Global Review of Islamic Economics and Business*, 4(2), 135.
- Vernanda, S. D., & Widyarti, E. T. (2016). Analisis Pengaruh CAR, LDR, NPL, BOPO, dan SIZE Terhadap ROA (Studi pada Bank Umum Konvensional yang Terdaftar di Bursa Efek Indonesia Periode 2010-2015). *Diponegoro Journal of Management*, 5(3), 1–13.
- Xu, S., Gong, G., & Gong, X. (2017). Accruals quality, underwriter reputation, and corporate bond underpricing: Evidence from China. *China Journal of Accounting Research*, 10(4), 317–339.