



# A Review of the Smart Grid Communication Technologies in Contactless Charging with Vehicle to Grid Integration Technology

Abdulgader Alsharif<sup>1\*</sup>, Tan Chee Wei<sup>1</sup>, Razman Ayop<sup>1</sup>, Kwan Yiew Lau<sup>2</sup>, Abba Lawan Bukar<sup>1</sup>

<sup>1</sup>Department of Electrical Power Systems, School of Electrical Engineering, Universiti Teknologi Malaysia, Malaysia

<sup>2</sup>Institute of high voltage and high current, School of Electrical Engineering, Universiti Teknologi Malaysia, Malaysia

## Abstract

Power needs to be transferred from the source to the load (electric vehicle). Transmitting electricity through the air gap for charging using electromagnetic waves as one of the smart grid technologies called Wireless Power Transfer (WPT), or Inductive Power Transfer. This paper presents the fulfilment of future grid that addresses the issues of Greenhouse Gas emission, and transportation and industries emissions known as the smart grid with a complex system. The complexity of the smart grid communication system is the motivation to be an open area of research issue. The main contribution of this paper is to close the gap between this research and other researches by delivering a comprehensive review and update the recent state-of-the-art of smart grid communication technologies with the integration of vehicle-to-grid (V2G) technology using the contactless charging method. Smart grid communication technologies with their pros and cons, topologies of wireless communication, challenges of the V2G, WPT challenges, and standards are discussed. Therefore, this study is expected to be a significant guide to engineers and researchers studying in the field of smart grid communication technologies and contactless charging for electric vehicles.

This is an open access article under the [CC BY-SA](https://creativecommons.org/licenses/by-sa/4.0/) license

## Keywords:

Electric Vehicle;  
Smart Grid;  
Vehicle-to-Grid;  
Wireless charging;  
WPT;

## Article History:

Received: February 1, 2021

Revised: April 11, 2021

Accepted: April 15, 2021

Published: April 30, 2021

## Corresponding Author:

Abdulgader Alsharif  
Department of Electrical Power  
Systems, School of Electrical  
Engineering, Universiti  
Teknologi Malaysia, Malaysia  
Email:

[habdulgader@graduate.utm.my](mailto:habdulgader@graduate.utm.my)



## INTRODUCTION

Due to the growing on the reduction of carbon dioxide (CO<sub>2</sub>) and air pollution among researchers that acquired from energy sources while generating electricity for charging vehicles. Electric vehicles (EV) charging is the trend among researchers nowadays due to the flexibility of using RESs and the main grid.

As the history of EV was invented in the United State by William Morrison in 1890, a six-passengers vehicle can be driven at 14 miles per hour at a maximum speed [1][2]. In 1898, Ferdinand Porsche created the first hybrid car. Additionally, the first EV created by Thomas Edison in 1914 collaborated with a famous car manufacturer, namely Henry Ford, at a low cost. Continuously developing EVs with various manufacturers and scientists from time to time, at the beginning of the twenty-first century, Japan was the first intuitive by producing a Toyota Prime [3]. However, using an electric utility for charging vehicles provides many challenges using conductive charging such as harmonic and power losses.

The challenges overcome by using a Smart Grid (SG) as the future network with several advantages [4], the provided advantages such as enhancing the reliability, efficiency, planning for the energy. Besides, SG able to address the limitations of the conventional grid, such as

transmission losses and power-quality degradation problem, by injecting RESs into the grid [5][6]. Thus, Gungor et al. [7] defined the SG as a modern power grid that improves the safety, efficiency, and reliability that can integrate other power resources.

The integration of smart grid system can bring many potential opportunities, especially from the perspective of V2G technology and as the solution for renewable energy intermittency issues [7]. Moreover, different types of charging to overcome the mentioned issues is presented as contactless charging or wireless charging. Furthermore, using either electric or electromagnetic waves depending on the transmitting device.

Wireless Power Transfer (WPT) using for EV charging and consists of two parts: transmitter and receiver coils, the former is hidden in the road and the latter is located in the EV [8]. In the literature, the classification and comparison of different technologies of WPT for EV charging presented in [9]. Additionally, the principal work of the WPT system is presented in [10]. The types of coils can be termed helix and spiral, where the former is a friendly used to investigate the effect of turn number and coil distance. In contrast, the latter is spiral that takes many forms (rectangular and circular), more flexible for optimization and attractive for EV charging applications [8]. In SG communication, different electronic devices are used, such as inverters and converters, to change the form of signals using different techniques, as will be presented with the comparison of them. As power flow classified used V2G technology into bidirectional and unidirectional [10]. Bidirectional converters can be used to exchange electricity between the grid and the vehicle. On the contrary, the unidirectional converter is using to deliver electricity from grid to battery as most of the charging systems used. One of the advantages of the unidirectional system is reducing battery degradation [11]. Even though, the connection operation can be done via international standards with many challenges. The main block diagram of the wireless charging system, as presented in Figure 1 [3][12]. The diagram consists of Alternative Current (AC) as a power supply. This AC rectified to DC through a rectifier (AC-DC) to enhance the efficiency [13]. Then the inverter (DC-AC) receives the DC signal to transfer it to AC to obtain high frequency in the primary coil [14], then the AC high frequency will transfer to the secondary coil via an inductive transformer. The inductive transformer is responsible for wireless charging operation, depending on the applications by using the compensator topologies to overcome the leaking inductance, better efficiency and improved characteristics [15] in primary and secondary coils [16]. The different topologies of compensators are stated in [3] and will be further described in this paper, and then to the rectifier (AC-DC) that linked to the EV battery as the end-user to charge the EV battery.

The contribution of this article is the extensive overview of SG communication technologies with their requirements for contactless charging and wireless power transfer challenges. The remain of this paper is organized as follows. Section 2, presented the background with smart grid communication types and their goals, Section 3, concepts of charging communication with cons of wireless charging. Section 4, classification of power flow in the V2G system. Section 5, presented the topologies of wireless communication. Challenges and standards for contactless charging and V2G technology placed in Section 6. Section 7, denoted for the smart grid communication requirement. Eventually, the conclusion in section 8 then the references.

## MATERIAL AND METHOD

### Smart Grid Communication Techniques

The first invention of transmitting power wirelessly in 1889 is Nikola Tesla by introducing Tesla coils that produced high voltage, high frequency [17]. Table 1 is given a further explanation of smart grid communications technologies [7][18]. The information can be passed through a smart meter named Advanced Metering Infrastructure (AMI).

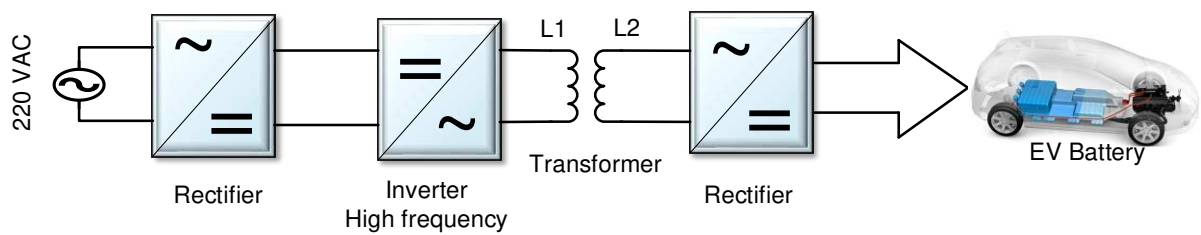

Figure 1. Basic block diagram of inductive charger [3][16]

Table 1. Smart Grid Communication Technologies [18][19]

SG techniques	Features
<b>Wireless Mesh</b>	Wireless Mesh is a popular system in North America and a flexible network system with many groups of nodes. Each node can act as an independent router. Some of the companies are using mesh networks for smart grid applications such as SKY Pilot Networks because of the high availability features and redundancy.
<b>ZigBee</b>	ZigBee is a wireless technology with many limitations compared to other smart grid communication technologies, such as data rate and low power usage. Contrary, it is the best one for smart lighting, automatic meter reading
<b>Power Line Communication</b>	Power Line Communication (PLC) is a technique used for existing power lines to transmit high-speed data signals from one device to other devices (2-3 Mbps). One of the hottest topics among scientists around the world compared to other smart communication techniques.
<b>Cellular Network Communication</b>	Cellular Network Communication is one of the smart technology techniques used for communicating between utilities and smart meter and between far nodes. Using cellular technology such as 2G, 3G, WiMAX, and LET for smart meter operation.
<b>Digital Subscriber Line</b>	Digital Subscriber Line (DSL) is the high-speed digital data transmission technology that uses the transmission data wires for telephone networks and remote control and monitoring substations.

To sum up, for smart grid communication techniques, using wiring technologies such as PLC and DSL can provide the ability to increase communication security, reliability, and capacity but they are costly. On the contrary, they are using wireless smart communication technologies that can diminish the cost and provide many limitations such as bandwidth and security. The advantages and disadvantages of smart grid communication technologies are explained in [Table 2](#).

### Charging Communications

Charging communications refer to the used types to charge EVs as wireless and wireline charging [3, 10, 20]. In addition, the classification of WPT technologies is two as reported and classified in [20] based on the distance of transmission, and used methods to obtain power transmission. Firstly, wireless charging using near-field which means the energy stayed in a small zone of the transmitter and secondly, far-field wireless charging [17].

### Wireless charging

Using WPT to transfer electricity from A to B by using either field near or far. EVs use near field as electromagnetic induction, which means from the grid to a vehicle (G2V) or vehicle to grid (V2G) and no wires involved. Wireless has a bit more advantages over the wireline. For instance, ease of connection, the charging process is friendly, and low cost. The V2G as an example of a wireless charging system by using magnetic waves and promising to be the future charging process [3][20].

Table 2. The advantages and disadvantages of smart grid communication technologies [18][19]

Types of smart grid communications	Advantages	Disadvantages
<b>Wireless Mesh</b>	<ul style="list-style-type: none"> <li>• Has many routers that act as nodes</li> <li>• Cost-effective solution with dynamin self-organization</li> <li>• Self-configuration and Self-healing</li> <li>• High scalability service</li> <li>- Improve the balance of the network</li> <li>- Converge network</li> <li>- Extending the network</li> </ul>	<ul style="list-style-type: none"> <li>• Network capacity</li> <li>• Fading</li> <li>• Interfacing</li> </ul>
<b>ZigBee</b>	<ul style="list-style-type: none"> <li>• Smart lighting and Energy monitoring</li> <li>• Low cost and bandwidth requirement</li> <li>• Home automation</li> <li>• Automatic meter reading</li> <li>• ZigBee and ZigBee Smart Energy Profile (SEP) most suitable standards for smart grid residential grid</li> </ul>	<ul style="list-style-type: none"> <li>• Low process capability</li> <li>• Small memory size</li> <li>• Short-range</li> <li>• Small delay requirements share the same transmission medium with other uses</li> </ul>
<b>Power Line Communication</b>	<ul style="list-style-type: none"> <li>• AMI implemented in urban areas to meet demand</li> <li>• Transfer data from data concentrator to utility data centre</li> <li>• Widely available infrastructure</li> <li>• Cost-effective and Secure system</li> <li>• The leading application for PLC is Home Area Network (HAN)</li> </ul>	<ul style="list-style-type: none"> <li>• PLC is noisy and strict</li> <li>• Low bandwidth characteristic that restricts application that needs high bandwidth</li> <li>• Wire distance between the transmitter and receiver affect the signal quality</li> <li>• The high sensitivity of PLC affects signal quality.</li> </ul>
<b>Cellular Network Communication</b>	<ul style="list-style-type: none"> <li>• Enable to generate and gather hug data</li> <li>• Strong data transmission security control</li> <li>• Manage health with smart meters in urban and rural regions</li> <li>• Using HAN, GPRS, AMI, Demand Response (DR) applications</li> <li>• Best smart grid communication for applications</li> <li>• Lower Maintenance cost and Fast installation features</li> </ul>	<ul style="list-style-type: none"> <li>• Congestion makes in the network by customers by sharing service of cellular network</li> <li>• Performance of network decreases for the emergency cases from the sharing of cellular network.</li> </ul>
<b>Digital Subscriber Line</b>	<ul style="list-style-type: none"> <li>• Best communication applicant for the electricity provider</li> <li>• Low cost</li> <li>• High bandwidth</li> </ul>	<ul style="list-style-type: none"> <li>• Long distances requiring a long cable and regular maintenance</li> <li>• Cannot implement in the rural area.</li> <li>• High-cost installation.</li> </ul>

### Wireline charging

The majority of EV users around the world are charging their vehicles via the wireline charging method. On the contrary, they have some disadvantages: user incompatibility, energy conservation, vehicle portability, consumption of space, and messy wired in wet areas [20]. In Figure 2, the comparison between two communication methods is illustrated. Wireline is using the port, while the wireless using magnetizing coupling for charging EVs.

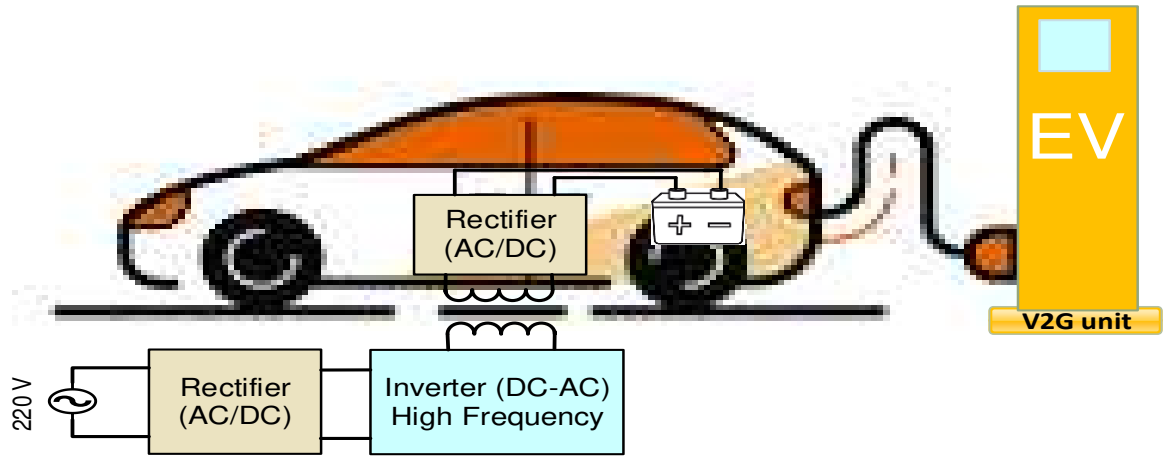

Figure 2. Wireless and wireline communication [10][20]

### Types of Power Flow

Bidirectional and unidirectional converters as power flow method as reported in [10][21]. The classification of V2G power flow, as demonstrated in Figure 3, is bidirectional and unidirectional and for the smart grid in electric vehicles systems with their sub-classifications as described in Table 3.

Table 3

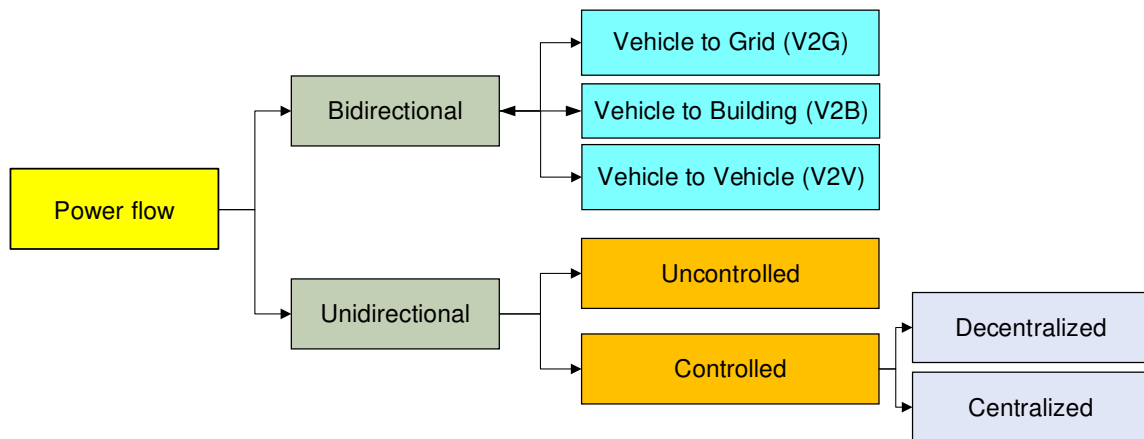

Figure 3. Power Flow Types [10, 22, 23]

Table 3. Classification of power flow [3, 10, 24]

Power flow directions	Explanation
<b>Unidirectional</b>	<ul style="list-style-type: none"> <li>• Transfer the electricity in one direction only Grid to Vehicle (G2V) as an example to size the equipment.</li> <li>• Lower the cost, and reducing battery degradation.</li> <li>• It uses a DC-DC converter and a diode bridge with a filter.</li> <li>• Divided into two categories as controlled and uncontrolled, the former sub-grouped into two centralised and decentralised groups.</li> </ul>
<b>Bidirectional</b>	<ul style="list-style-type: none"> <li>• Electricity flowed to the battery can be injected back to the grid.</li> <li>• Using many topologies for exchange the electricity from the vehicle, which is a vehicle to grid (V2G), vehicle to home (V2H), vehicle to building (V2B), and vehicle to vehicle (V2V).</li> <li>• Providing ancillary services operations.</li> <li>• Using a vehicle to network (V2N) with millimetre-wave communication.</li> <li>• WPT presents many merits such as safety and convenience.</li> </ul>

### Compensator Topologies in Wireless Communication

Topologies in the contactless transfer system that is known as compensator topologies. They classified into two groups as basic and hybrid as reported in [16], the basic can be subcategorized into four groups as tabulated in Table 4 with further details and shaped in Figure 4 [3][15]. Furthermore, the leaking inductance in the coils can be overcome by the compensators.  $M$  refers to the coupling coefficient coils and  $V_s$  is the AC source (220 V),  $R_1$  and  $R_2$  are resistant for primary and secondary coils.  $C_1$  and  $C_2$  are capacitors for primary and secondary coils, and  $R_L$  is the end-user [12].

Table 4. Topologies of the compensator in wireless charging [12]

Compensator topologies	Explanation
Series-Series	Series-Series indicated as (SS) which illustrated in Figure 4 (a), shows the series flow between primary and secondary transformer.
Series-Parallel	Series-Parallel and symbolized as (SP) in Figure 4 (b) that behave the same as Parallel-parallel.
Parallel-Series	used in wireless charging to address the leaking on the coils and denoted as (PS) that presented in Figure 4 (c) according to a study used PS compensator and resulted in that poor in alignment tolerance.
Parallel-Parallel	It is denoted as (PP) and demonstrated in Figure 4 (d) that behave the same as series-parallel according to a cited study.

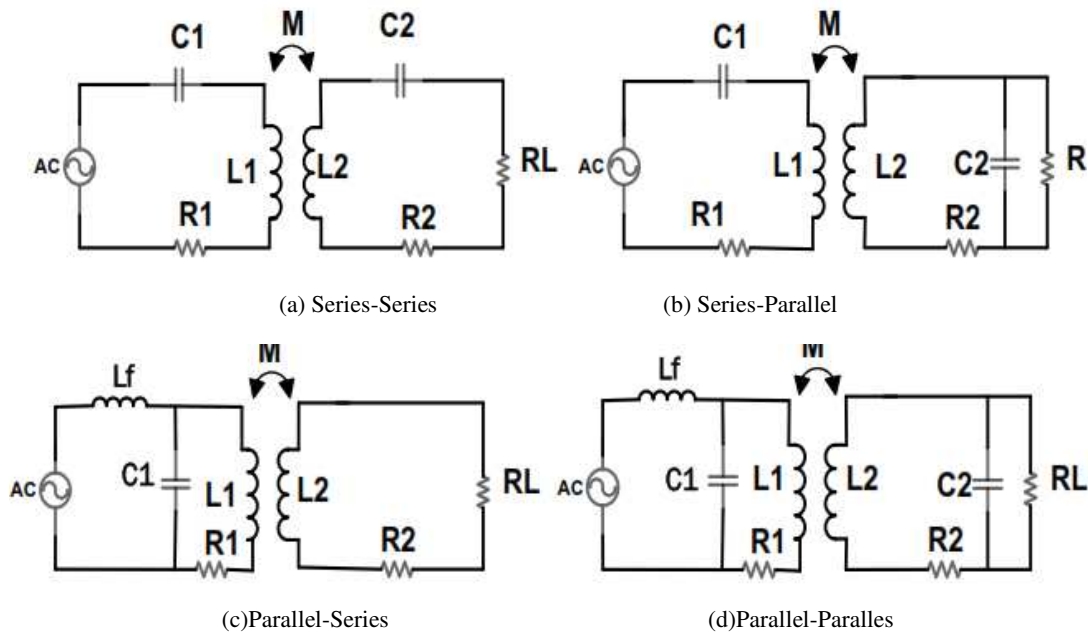

Figure 4. Topologies of inductive charging compensator [3, 16, 22]

### Challenges and Standards for Contactless Charging

In this segment, as pointed out, the challenges of V2G technology are presented in the subsection. Besides the challenges of WPT and their further explanation tabulated in Table 5 and reported in [3], the standards of wireless charging are presented in Table 5.



### ***V2G challenges***

The challenges of V2G as battery degradation that reduces the age of the battery, maintenance that is not available everywhere, connectivity which is not all vehicles have the same connectors. The finance indicates the cost of the vehicles, which is expensive [25], and the standards for wireless charging are discussed in this section.

Table 5. Challenges of Wireless Power Transfer [3][26]

<b>Challenges</b>	<b>Description</b>
<b>Transfer efficiency</b>	It is a challenge of transferring power in wireless charging. It is less in wireless technology.
<b>Coupling separation</b>	It varies between primary and secondary coils. When the separation increase, the coupling coefficient drops
<b>Alignment tolerance</b>	It designed for feasible operation where high efficiency for a range should be delivered
<b>Interface</b>	Where the transmitter and receiver pads located before the circuitry or framework of the vehicle.
<b>Safety</b>	Because there is no medium guidance for WPT, that lead to distributing of electromagnetic wave and individually affect in the district, give a direction element by magnetic resonance can solve the effects.
<b>According to ICNIRP 2010</b>	It is a safety standard, used for general exposure and occupational exposure with their frequency ranges.
<b>Winding resistance</b>	As the main challenge of WPT, the losses in the coil can be addressed by using a multi-standard coil-like LITZ.

### ***Standards of contactless charging***

The frequency of transmitting current is 10-150 kHz [8]. Globally, people connect devices to get the benefit from the electricity and feed those devices. EV is one of them that using electricity to charge the battery to allow the users to acquire the benefit. The EVs can be connected using either wireline or wireless with different standards depends on the location. The USA, for instance, using the American National Standards Institute (ANSI). The standards used in Europe is IEC which stands for International Electro Technical Commission, Institute of Electrical and Electronics Engineers (IEEE), and Society of Automotive Engineers (SAE). The summary of the inductive charging standard system is tabulated in [Table 6](#).

### **Smart Grid Communication Requirements**

The most important part of this section is security, to avoid the risks and hackers that lead the users to be aware and looking for the solution to prevent it with the other requirements as described in [Table 7](#).

Table 6. Summary of contactless charging standards [7][20]

Standard name	Standards	Description
<b>Revenue metering information model</b>	ANSI C12.19	For utility industry end device data table. Define the table for transmission between the end device and computer using binary code and XML.
	M-Bus	For providing remotely reading equipment, European standard.
	ANSI C12.18	For meter communication and mature for two-way communication between the smart meter and customer
	BACnet	Responsible for building automation and control networks and supports the building integration
<b>Building automation</b>	IEC 61850	Define the communication between devices and substation automation systems.
<b>Substantial automation</b>	HomePlug	Using to connect the intelligent appliances to HAN, create a reliable HAN between electric appliances and smart meter.
	HomePlug Green PHY	Developed as low power, cost-optimization power line for smart grid communication that used in residential areas.
	PRIME	Provides multi-vendor interoperability and hospialities several entities to its mass.
	G3-PLC	Provide interoperability, robustness; reduce the infrastructure costs and cybersecurity.
<b>Home Area Network Device Communication Measurement and Control</b>	U-SNAP	Support many communication protocols to connect HAN appliances to smart meter
	IEEE P1901	Used for high-speed power line communication to meet home installations
	Z-Wave	It is another solution to ZigBee that handles the interface with 802.11/b/g
<b>Application energy management</b>	IEC 61970 and IEC 61968	Provide a common information model for exchange the data between appliances and the grid. IEC61970 work in the transmission domain, IEC61968 works in the distribution domain.
	OpenADR	Provide effective deployment of dynamic pricing, grid reliability, and demand response.
	IEEE P2030	It is a smart grid guide for interoperability of energy technology and information technology operation with EPS
<b>Inter-control and inter-operability Centre communication</b>	ITU-T G.9955 and G.9956	Includes the two layers of physical specification and data link specification
	ANSI C12.22	Define the protocol for transporting ANSI C12.19 table data
	ISA 100.11a	Using for a wireless system for industrial automation
	IEC 62351	Define cybersecurity for communication protocols.
<b>Cyber security</b>	SAE J2293	Standardizes the electrical energy from the grid to EVs
	SAE J2847	Supports energy transfer between PHEV and grid
<b>Electric vehicles</b>	SAE J2836	Supports communication messages between PEV and grid kits

Table 7. Smart grid communication requirements [7][18]

Requirements	Explanation
<b>Security</b>	To have a wireless security network and avoided hackers for many risks. Supporting secure communication between remote control and field devices from denial-of-service attacks (DoS).
<b>Robustness</b>	Improving the wireless networking protocol Avoid getting worse communication for varying traffic conditions
<b>Scalability</b>	To present the huge number of the nodes in the network, the system must be able to deal with large network topologies
<b>Quality of Service</b>	This refers to the accuracy between the reported data to the control centre and the occurring in the environment. To manage the data, the internet cannot promise a very close QoS for application demand. To reduce the limitations such as invisibility and losses.



## CONCLUSION

A comprehensive overview to update the state-of-the-art smart grid communication technologies using to transfer information and charge EVs have been analyzed. In this paper, a wireless charging diagram illustrated charging a vehicle's battery. In terms of distributing power, power flow classification is also bidirectional and unidirectional with their sub-classifications in this article with the four compensator topologies for wireless charging. Furthermore, smart grid communication requirements, challenges for V2G, and WPT challenges are also discussed in this article with the standards of a contactless charging system described before.

## REFERENCES

- [1] Y. Ma et al., "An overview on V2G strategies to impacts from EV integration into power system," *2016 Chinese Control and Decision Conference (CCDC)*, Yinchuan, China, 2016, pp. 2895-2900, doi: 10.1109/CCDC.2016.7531477
- [2] C. Qiu, K. T. Chau, T. W. Ching, and C. Liu, "Overview of Wireless Charging Technologies for Electric Vehicles," *Journal of Asian Electric Vehicle*, vol. 12, no. 1, pp. 1679–1685, 2014, doi: 10.4130/jaev.12.1679
- [3] P. K. Joseph, E. Devaraj, and A. Gopal, "Overview of wireless charging and vehicle-to-grid integration of electric vehicles using renewable energy for sustainable transportation," *IET Power Electronics*, vol. 12, no. 4, pp. 627–638, Apr. 2019, doi: 10.1049/iet-pel.2018.5127
- [4] G. Dileep, "A survey on smart grid technologies and applications," *Renewable Energy*, vol. 146, pp. 2589–2625, 2020, doi: 10.1016/j.renene.2019.08.092
- [5] K. Uddin, M. Dubarry, and M. B. Glick, "The viability of vehicle-to-grid operations from a battery technology and policy perspective," *Energy Policy*, vol. 113, pp. 342–347, Feb. 2018, doi: 10.1016/j.enpol.2017.11.015
- [6] S. M. Shariff, D. Iqbal, M. Saad Alam, and F. Ahmad, "A State of the Art Review of Electric Vehicle to Grid (V2G) technology," *IOP Conference Series Material Science Engineering*, vol. 561, no. 1, p. 012103, Nov. 2019
- [7] G. P. H. Vehbi C. Gungor, Dilan Sahin, Taskin Kocak, Salih Ergüt, Concettina Buccella, Carlo Cecati, "Smart Grid Technologies: Communication Technologies and Standards," in *IEEE Transactions on Industrial Informatics*, vol. 7, no. 4, pp. 529-539, Nov. 2011, doi: 10.1109/TII.2011.2166794
- [8] S. Li and C. C. Mi, "Wireless Power Transfer for Electric Vehicle Applications," in *IEEE Journal of Emerging and Selected Topics in Power Electronics*, vol. 3, no. 1, pp. 4-17, March 2015, doi: 10.1109/JESTPE.2014.2319453
- [9] C. Qiu, K. T. Chau, C. Liu and C. C. Chan, "Overview of wireless power transfer for electric vehicle charging," *2013 World Electric Vehicle Symposium and Exhibition (EVS27)*, 2013, pp. 1-9, doi: 10.1109/EVS.2013.6914731
- [10] H. S. Das, M. M. Rahman, S. Li, and C. W. Tan, "Electric vehicles standards, charging infrastructure, and impact on grid integration: A technological review," *Renewable Sustainable Energy Reviews*, vol. 120, p. 109618, Mar. 2020, doi: 10.1016/j.rser.2019.109618
- [11] M. Yilmaz and P. T. Krein, "Review of charging power levels and infrastructure for plug-in electric and hybrid vehicles," *2012 IEEE International Electric Vehicle Conference*, USA, 2012, pp. 1-8, doi: 10.1109/IEVC.2012.6183208
- [12] A. K. Rathore and S. Samanta, "Wireless power transfer technology using full-bridge current-fed topology for medium power applications," *IET Power Electronics*, vol. 9, no. 9, pp. 1903–1913, Jul. 2016, doi: 10.1049/iet-pel.2015.0775
- [13] P. Livreri, V. Di Dio, R. Miceli, F. Pellitteri, G. R. Galluzzo and F. Viola, "Wireless battery charging for electric bicycles," *2017 6th International Conference on Clean Electrical Power (ICCEP)*, Italy, 2017, pp. 602-607, doi: 10.1109/ICCEP.2017.8004750
- [14] Y. Chen, W. Wei, F. Zhang, C. Liu and C. Meng, "Design of PV hybrid DC/AC microgrid for electric vehicle charging station," *2017 IEEE Transportation Electrification Conference and Expo, Asia-Pacific (ITEC Asia-Pacific)*, Harbin, China, 2017, pp. 1-6, doi: 10.1109/ITEC-AP.2017.8081027
- [15] P. K. Joseph and D. Elangovan, "A review on renewable energy powered wireless power transmission techniques for light electric vehicle charging applications," *Journal of Energy Storage*, vol. 16, pp. 145–155, 2018, doi: 10.1016/j.est.2017.12.019

- [16] M. Abou Houran, X. Yang, and W. Chen, "Magnetically Coupled Resonance WPT: Review of Compensation Topologies, Resonator Structures with Misalignment, and EMI Diagnostics," *Electronics*, vol. 7, no. 11, p. 296, Nov. 2018, doi: 10.3390/electronics7110296
- [17] J. Macharia, "Wireless Inductive Charging for Low Power Devices," in *Energy Harvester for Low Power Devices*, 2017
- [18] V. C. Gungor and F. C. Lambert, "A survey on communication networks for electric system automation," *Computer Networks*, vol. 50, no. 7, pp. 877–897, May 2006, doi: 10.1016/j.comnet.2006.01.005
- [19] D. Baimel, S. Tapuchi and N. Baimel, "Smart grid communication technologies- overview, research challenges and opportunities," *2016 International Symposium on Power Electronics, Electrical Drives, Automation and Motion (SPEEDAM)*, Capri, Italy, 2016, pp. 116-120, doi: 10.1109/SPEEDAM.2016.7526014
- [20] A. Ahmad, M. S. Alam and R. Chabaan, "A Comprehensive Review of Wireless Charging Technologies for Electric Vehicles," in *IEEE Transactions on Transportation Electrification*, vol. 4, no. 1, pp. 38-63, March 2018, doi: 10.1109/TTE.2017.2771619
- [21] C. K. Hridya, R. Hari Kumar and N. Mayadevi, "Wireless Bidirectional Power Transfer with Maximum Efficiency Point Tracking Control in Electric Vehicles," *2020 IEEE International Conference on Power Electronics, Smart Grid and Renewable Energy (PESGRE2020)*, 2020, pp. 1-7, doi: 10.1109/PESGRE45664.2020.9070704
- [22] J. Y. Yong, V. K. Ramachandramurthy, K. M. Tan, and N. Mithulananthan, "A review on the state-of-the-art technologies of electric vehicle, its impacts and prospects," *Renewable and Sustainable Energy Reviews*, vol. 49, pp. 365–385, 2015, doi: 10.1016/j.rser.2015.04.130
- [23] K. Mahmud, G. E. Town, S. Morsalin, and M. J. Hossain, "Integration of electric vehicles and management in the internet of energy," *Renewable and Sustainable Energy Reviews*, vol. 82, no. 3, pp. 4179–4203, Feb. 2018, doi: 10.1016/j.rser.2017.11.004
- [24] N. Shaukat et al., "A survey on electric vehicle transportation within smart grid system," *Renewable and Sustainable Energy Reviews*, vol. 81, Part. 1, pp. 1329–1349, Jan. 2018, doi: 10.1016/j.rser.2017.05.092
- [25] Y. Zheng, Z. Y. Dong, Y. Xu, K. Meng, J. H. Zhao and J. Qiu, "Electric Vehicle Battery Charging/Swap Stations in Distribution Systems: Comparison Study and Optimal Planning," in *IEEE Transactions on Power Systems*, vol. 29, no. 1, pp. 221-229, Jan. 2014, doi: 10.1109/TPWRS.2013.2278852
- [26] T. S. Chandrasekar Rao and K. Geetha, "Categories, Standards and Recent Trends in Wireless Power Transfer: A Survey," *Indian Journal of Science and Technology*, vol. 9, no. 20, pp. 1-11, May 2016, doi: 10.17485/ijst/2016/v9i20/91041