

## Development of Walker Using Visual Cue with Monitoring Application Based on Internet of Things (IoT) for Parkinsonian Gait

(Pembangunan Walker Menggunakan Visual Cue dengan Aplikasi Pemantauan Berdasarkan  
Internet of Things (IoT) untuk Parkinsonian Gait)

\*NUR ALIAH BINTI ROZMAN, ZUNUWANAS BIN MOHAMAD  
Politeknik Sultan Salahuddin Abdul Aziz Shah

### Abstract

Freezing of Gait (FoG) is one of the major issues that suffered by Parkinson's patients that may lead to loss of independence. One of the most method used by physiotherapist to improve the difficulty of walking is by visual cueing that help to draw attention and creates an immediate increase in the range of specific emotions. In relation, mobility aids such as walkers are used as a medium to assist the patient's movement along with the implementation of visual cues. To overcome the problems, this walker provides a combination of visual cues application, walking speed limit for the patient, and wireless monitoring operation based on the Internet of Things (IoT). The parameters like walking step and distance are the measurement in determining patient progression. The objective of this research to design a walker with the concept of visual caring for Parkinson's patient, o develops an application for a rehabilitation monitoring system based on the Internet of Things (IoT) and to analyze the data of patient progression based on the output of step count and distance.

Keywords: Freezing of Gait (FoG), Parkinson's patient, visual cues, rehabilitation, Internet of Things (IoT)

**Received:** August 25, 2020; **Accepted:** October 28, 2020; **Published:** October 21, 2021

© 2021 PKS. All rights reserved.

\* Corresponding author: aliahroz97@gmail.com

## INTRODUCTION

Parkinson's disease (PD) is a chronic progressive disorder that mainly affecting the motor system. PD is usually controlled by drug treatment such as dopamine intake and motor rehabilitation to reduce complications and to train patients in the use of compensatory movement strategies (Abbruzzese, Trompetto, & Marinelli, 2009). Besides, Parkinson's patient who is facing Freezing of Gait (FoG) is significantly affects the quality of life of a patient because the FoG may lead to loss of independence on as axial motor disability, cognitive impairment, and falling (Velik, Hoffmann, Zabaleta, Marti Masso, & Keller, 2012; Okuma, 2014). They are three forms of FoG that have been identified which is a purely, a tremble in place, and a shuffling while walking (Sweeney, Quinlan, Browne, Richardson, Meskell, & O'laighin, 2019). The PD infecting over 4 million individual worlds widely and is expected to increase by times due to aging population escalation. studies showed that PD patients have abnormal postural coordination only when vision was obscured, which is consistent with impaired proprioceptive mapping compensated by the use of vision of the body and the sensory feedback treatment able to control balance and reduce the postural sway of the patient (Konczak et al., 2009; Rabin, Chen, Muratori, DiFrancisco-Donoghue, & Werner, 2013). In relation, this paper presents the development of a visual cueing device based on optical flow for the assistive device to treat parkinsonism especially during the Freezing of Gait Episodes. To elaborate, many related studies apply research concepts to sensory cueing. According to Azulay, Mesure, and Blin (2006), sensory cueing is used for a long time to improve gait in patients with Parkinson's disease. Besides that, the use of Internet of Things (IoT) technology can provide an information network to many receivers such as health services and communities.

## LITERATURE REVIEW

### Parkinson's Disease

Parkinson's disease is chronic progressive nervous system disorder that affect motor system in patient movement as in Figure 1. In addition, Parkinson's patient is partially controlled by medication treatment which is known as symptomatic dopaminergic treatment. Therefore, motor rehabilitation treatment is one of alternative method that can be used in Parkinson's disease to reduce complications and to train patients in the use of compensatory movement strategies (Azulay et al., 2006). Along with Parkinson's disease, Freezing of Gait (FoG) is a common phenomenon in Parkinson's patient which significantly affects quality of life. Hence, sensory cues are a one of method that usually used to improve walking performance and reduce Freezing of Gait (FoG).

### Visual Cueing

Cueing systems is a well-established technique that has been shown to improve gait in people with Parkinson's including walking speed, step length, cadence (total number of steps taken per minute), and reducing the number of Freezing of Gait (FoG) episodes (Sweeney et al., 2019)). According to Sweeney et al. (2019) also, there is three sensory cueing practices technique exists that widely used which is: visual cueing, auditory cueing, and somatosensory cueing. Visual cues provide visual stimuli (Sweeney et al., 2019). In relation, based on other related studies visual cues are elaborated as are one of the methods of sensory cueing that are extrinsic feedback mechanisms to enhance motor learning as shown in Figure 2. The process is developed by obtaining information through the optical flow of stepping feet in an accurate position while walking in the visual cues pattern's platform (Sunny & Bhat, 2017). Thus, cueing techniques system work to stimulate the proprioceptive inputs to enhanced information on limb position and movement during gait (Sweeney et al., 2019).

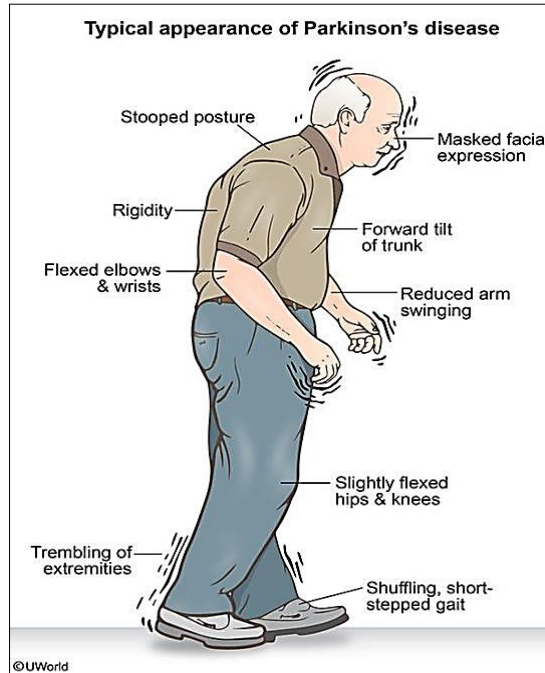

Figure 1. Illustration of Parkinson's Disease Appearance

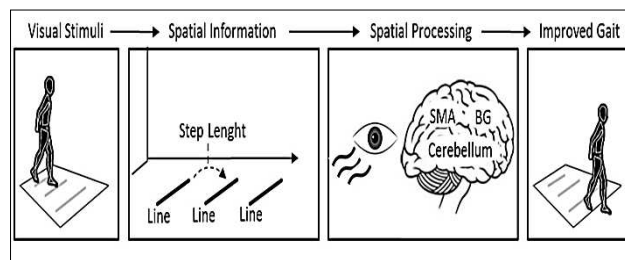

Figure 2. Concept of Visual Cueing (Source: Sweeney et al., 2019)

### Parkinsonian Gait and Symptom

Parkinsonian gait is characterized by small shuffling steps, less steady walk that arises from changes in posture, slowness of movement (bradykinesia), and a shortened stride while walking in Parkinson's patient (Abbruzzese, Trompetto, & Marinelli, 2009). To elaborate, there are three forms of Freezing of Gait (FoG) that have been identified, which are: a pure akinesia form (no motion of the person's legs is observed); a "tremble in place" form (inability of the person to step with their legs trembling at a frequency of 2 to 4 Hz) and a "shuffling" form (spontaneous increase in cadence and decrease in step length) (Sweeney et al., 2019). Freezing of Gait (FOG) is a restricting phenomenon in Parkinson's disease (PD) that may lead to loss of independence and fall in Parkinson's patients. Besides, Movement abnormalities such as tremor, bradykinesia, rigidity, and postural problems are found as clinical hallmarks of Parkinson's disease (PD). And they are thought to arise primarily from the loss of dopamine-producing neurons and subsequent dysfunction of the Cortical-basal ganglia pathways as shown in Figure 3.

### Arduino Uno

Arduino is an open-source electronics platform based on easy-to-use hardware and software. Arduino boards can read inputs such as light on a sensor, a finger on a button, and able to turn it into an output to activating a motor, turning on an LED, and interpret the result online. Besides that, the Arduino programming language (based on Wiring), and the Arduino Software

(IDE), based on Processing are related and working together as one function. As shown in Figure 4.

### Rollator Walker

An ultrasonic sensor as shown in Figure 5 is an electronic device that measures the distance of a target object by emitting ultrasonic sound waves and converts the reflected sound into an electrical signal. Ultrasonic waves travel faster than the speed of audible sound. The ultrasonic sensors have two main components that operated the sensor which is the transmitter (which emits the sound using piezoelectric crystals) and the receiver (which encounters the sound after it has traveled to and from the target) (De Icco et al., 2015).

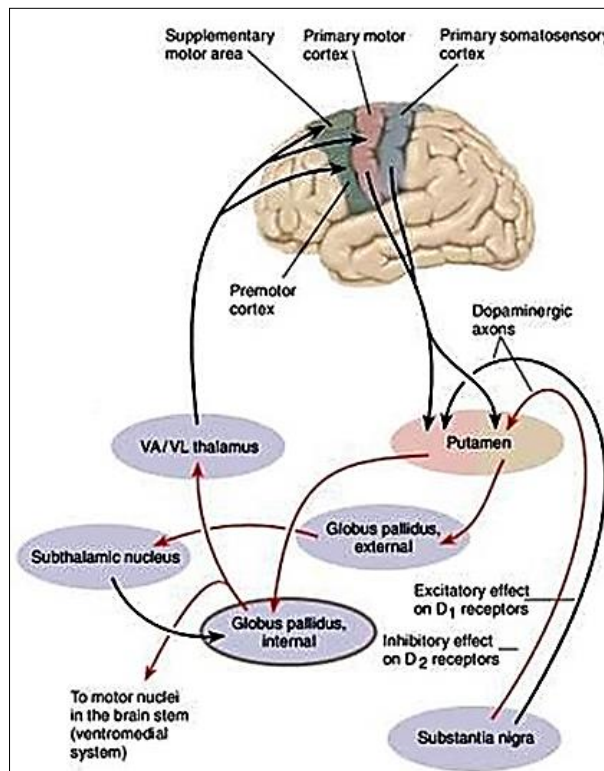

Figure 3. Cortical-Basal Ganglia Pathways

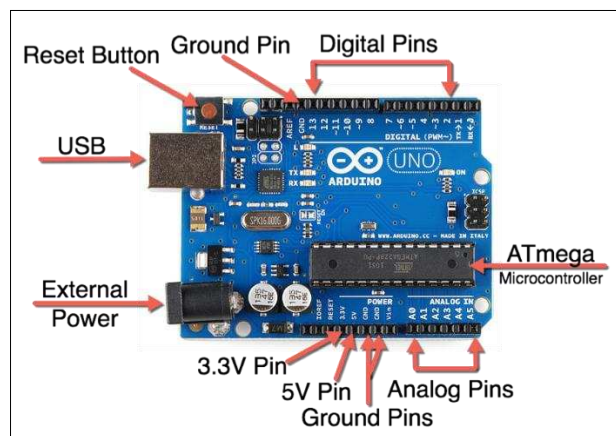

Figure 4. Arduino Uno



Figure 5: Ultrasonic Module

## METHODOLOGY

### PLANNING OF PRODUCT DEVELOPMENT

The product is creating according to four development stages as shown in Figure 6, such as Identifying problems, design products based on suitable material, product tests, data collection, and analysis of the data. The planning flowchart is used to help in guiding the development of the product in time. To elaborate on those four stages:

- Phase I = the development of a product base on observation of potential problems occurs from the sources, such as field study or literature review.
- Phase II = the product is developed according to the studies done on product design and suitable material on the mechanical part, electronic part, and hardware part.
- Phase III = product is tested based on rehabilitation abilities, electrical connection safe, and load test in order to avoid the possible problems in the future.
- Phase IV = the data analysis was done by explaining the whole process of data collection in detail and able to express the data into a chart or graph as a step to see the clear result in detail.

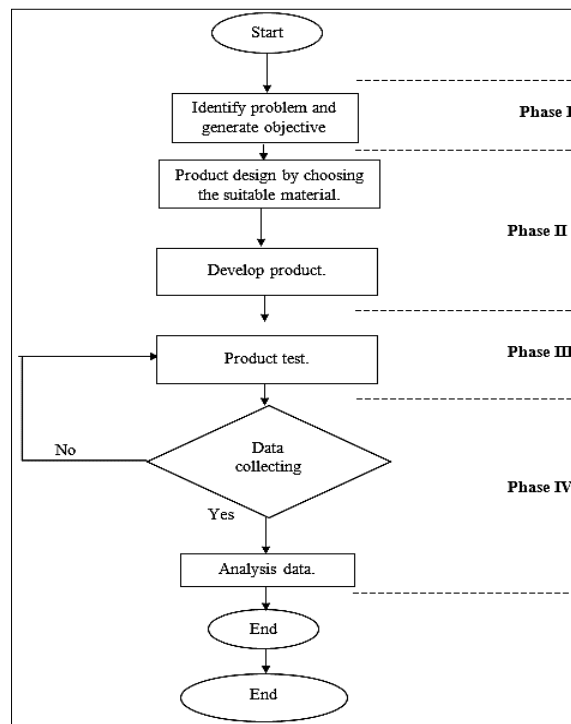

Figure 6. Flow chart of product development

## FLOW CHART OF PRODUCT WHEN UNDER OPERATE

At first, the operating device which is a rollator walker needs to have a Bluetooth connection with the MIT application from the smartphone as shown in Figure 7. Once the device is connected, the user able to control the walker speed by adjusting the speed controller on the screen. Besides that, the user also able to monitor the current session distance, total distance, current session step, and total step. Next, when the user completed the rehabilitation treatment, they need to upload the data to Google Sheet. To elaborate, the Google Sheet containing the treatment data will be accessed by third-party users such as doctors or medical officers through a google website link that collaborates with the MIT application. Hence, the treatment able to be monitored and done precisely.

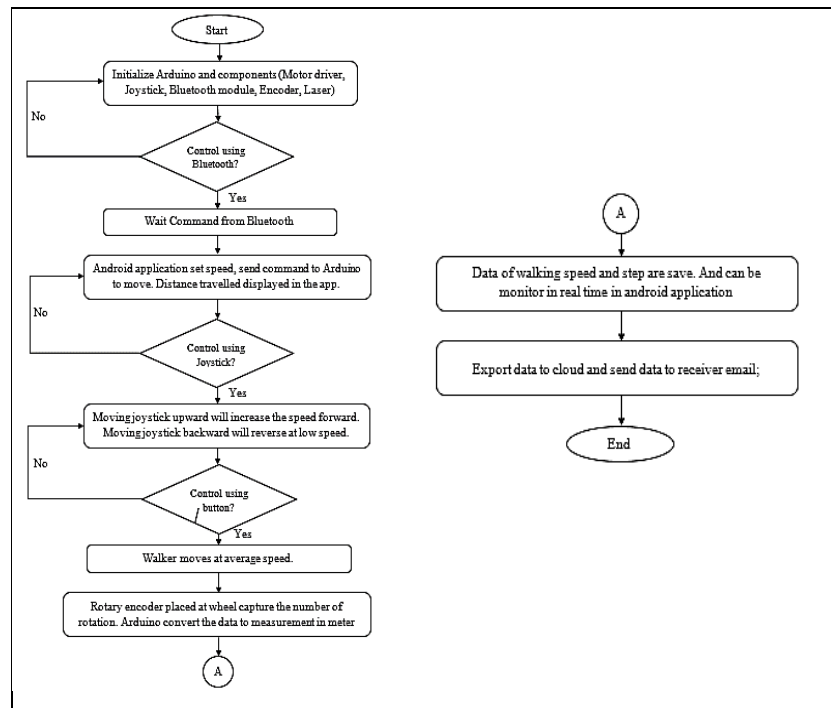

Figure 7. Flow chart of product

## TESTED SUBJECT

To test the usability of the Visual Cue Walker the experiment is conducted on subject A and subject B which both are healthy participants in the average age of 23 years. Both subjects were required to walk with Visual Cue Walker for 1 minute to 10 minutes gradually, to compare both measured values from participants in terms of step count and distance measured. Next, the result obtains from MIT Walker Apps is recorded.

## EXPERIMENTAL SETUP

The focus of the experiment is to collect and monitor the walking step and distance of healthy participants as for usability test. The participants were asked to walk with the operating device. Visual Cue Walker is configured as follows before beginning:

- The operating device which is a walker needs to have a Bluetooth connection with MIT application from the smartphone.
- Once the device is connected, the user able to control the walker speed by adjusting the speed controller on the screen as shown in Figure 8. The subject needs to placed their foot inside the laser guide while walking, in order to calculate the step count as shown in Figure 9.

- Start the experiment by monitor the current session distance, total distance, current session step, and total step.
- Completed the rehabilitation treatment they need to upload the data to Google Sheet. the Google Sheet that containing the treatment data will be accessible by a google website link that collaborates with the MIT application.

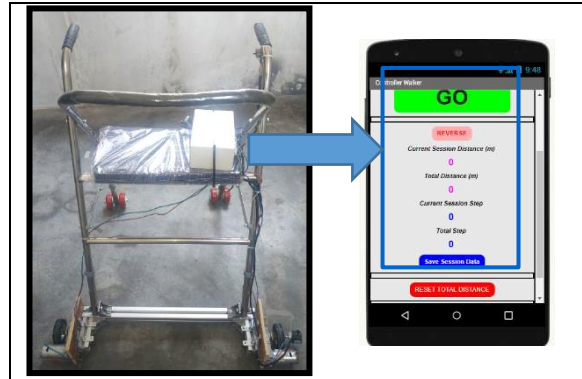

Figure 8. Smartphone application measuring output parameter



Figure 9. Subject stepping inside the laser guide

The data that have been measured by the MIT application is saved by pressing the "save session data" button on Apps and then the data able to be view in Google sheet form. The exporting data are appeared in table form and presenting the times, date, distance, and step that have been recorded as shown in Figure 10. Thus, in this form the data able to access by other users or third-party users by sharing or sending the google link that containing this data and can be downloaded in PDF form. Data appear on google sheet in only the data that we decided to save on MIT apps. Otherwise, it will not be saving the current session data and only showing the previous data collection.

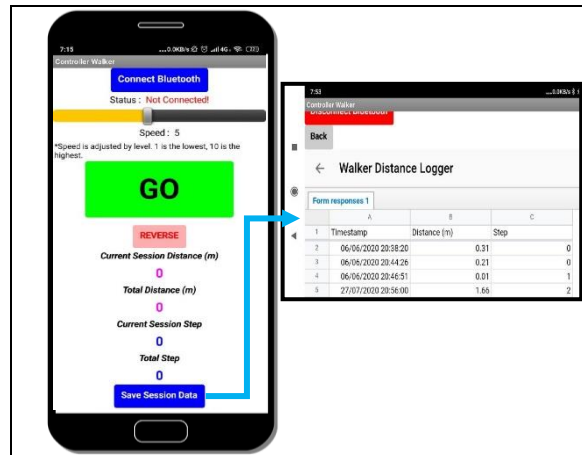

Figure 10. Data exporting into Google Sheet

## RESULTS AND DISCUSSION

The data collection of exercise manual based on a healthy person is based on a usability test, the experiment is conducted on subject A and subject B as shown in Table 1 and Table 2. both subjects required to walk with Visual Cue Walker for 1 minute to 10 minutes gradually, to compare between both measured value from participants in term of step count and distance measured. Next, the result obtains from MIT Walker Apps is recorded.

### STEP COUNT

The result observed from Figure 11 revealed both participants show the same performance of step and there is no huge difference between the two measured values of both participants. The comparison of both subjects in terms of step count is almost the same. Thus, this experiment proves the healthy participants walk with the same step while using this Visual Cue Walker in the same period.

Table 1. The step count data for both subject

Time	Step		Average
	Subject A	Subject B	
1 Minute	9	11	10
5 Minute	35	39	37
10 Minute	68	73	70.5

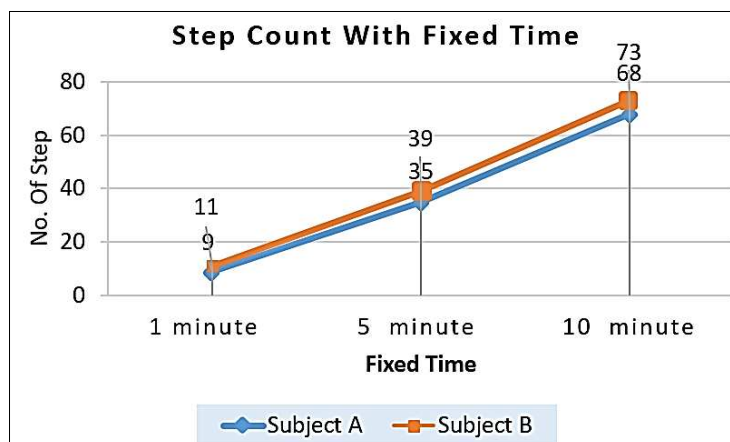

Figure 11: Line graph of step count



## DISTANCE

The result observed from Figure 12 revealed both participants show the same performance of distance and there is no huge difference between the two measured values of both participants. The comparison of both subjects in terms of distance is almost the same. Thus, this experiment proves the healthy participants walk at the same distance while using this Visual Cue Walker at the same time.

**Table 2. The distance measured for both participant**

Time	Distance (meter)		Average
	Subject A	Subject B	
1 Minute	5.40	7.03	6.22
5 Minute	25.52	25.87	25.70
10 Minute	50.68	56.54	53.61

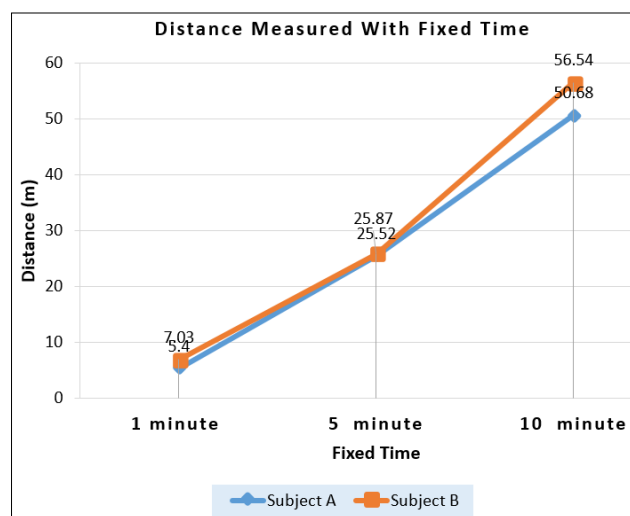

Figure 12. Line graph of distance

## **CONCLUSION**

The project aims to produce a rollator walker that specifically build for Parkinson's patient who is facing terrible Freezing of Gait (FoG) while walking at affordable price. Besides, this device was designed with optical visual cues, a speed-controlled motor, and a rehabilitation status monitoring system, which is used to help healthcare officers analyze the patient progression based on the output of step count and walking distance. Also, this project develops to create a program that is used by an acceleration sensor that is equipped into a rollator walker.

Hence, the walker with visual cues for Parkinson's patients with monitoring applications based on the Internet of Things (IoT) is developed for purpose of helping the user, guardian, and health officer to monitor patient rehabilitation progress effectively. Besides that, many existing devices that applying the concept of visual cues is expensive and doesn't have a wireless monitoring system. In relation, certain user costs and functions are the main factors in choosing a product.

## **REFERENCES**

Abbruzzese, G., Trompetto, C., & Marinelli, L. (2009). The rationale for motor learning in Parkinson's disease. *European Journal of Physical and Rehabilitation Medicine.*, 45(2), 209–214.

- Azulay, J. P., Measure, S., & Blin, O. (2006). Influence of visual cues on gait in Parkinson's disease: Contribution to attention or sensory dependence? *J. Neurol. Sci.*, 248(1-2), 192–195. doi: 10.1016/j.jns.2006.05.008
- Bateni, H., & Maki, B. E. (2005). Assistive devices for balance and mobility: Benefits, demands, and adverse consequences. *Arch. Phys. Med. Rehabil.*, 86(1), 134–145.
- De Icco, R., Tassorelli, C., Berra, E., Bolla, M., Pacchetti, C., & Sandrini, G. (2015). Acute and chronic effect of acoustic and visual cues on gait training in Parkinson ' s disease : A randomized, controlled study. *Parkinson's Disease* (2015). Retrieved from <https://www.hindawi.com/journals/pd/2015/978590/>
- Fedorov, D. S., Ivoylov, A. Y., Zhmud, V. A., & Trubin, V. G. (2015). Using of measuring system MPU6050 for the determination of the angular velocities and linear accelerations. *Automatics & Software Enginery*, 1(11), 76-81.
- Fitriani, D. A., Andhyka, W., & Risqiwati, D. (2017). Design of monitoring system step walking with MPU6050 sensor based android. *Journal Informatics, Network, Comput. Sci.*, 1(1), 1.
- Konczak, J., Corcos, D. M., Horak, F., Poizner, H., Shapiro, M., Tuite, P., ... Maschke, M. (2009). Proprioception and Motor Control in Parkinson's Disease. *Journal of Motor Behavior*, 41(6), 37–41.
- Konczak, J., Sciutti, A., Avanzino, L., Squeri, V., Gori, M., ... Sandini, G. (2012). Parkinson's disease accelerates age-related decline in haptic perception by altering somatosensory integration. *Brain*, 135(11), 3371–3379.
- Okuma, Y. (2014). Freezing of gait and falls in Parkinson's disease. *Journal of Parkinson's Disease.*, 4(2), 255–260.
- Rabin, E., Chen, J., Muratori, L., DiFrancisco-Donoghue, J., & Werner, W. G. (2013). Haptic feedback from manual contact improves balance control in people with Parkinson's disease. *Gait Posture*, 38(3), 373–379.
- Sankaran, R., Freeman, J., & Aravind, R. (2014). Design and implementation of a low-cost laser Parkinson's walker with safety and energy saving features. *2014 IEEE Glob. Humanit. Technol. Conf. - South Asia Satell. GHTC-SAS 2014*, 83–86.
- Sunny, S., & Bhat, S. P. S. (2017). Effect of visual cue training on balance and walking in elderly: A single blind randomized controlled trial. *Journal of Clinical and Diagnostic Research*, 11(11), YC01–YC04.
- Sweeney, D., Quinlan, L. R., Browne, P., Richardson, M., Meskell, P., & Ólaighin, G. A technological review of wearable cueing devices addressing freezing of gait in Parkinson's disease. *Sensors (Switzerland)*, 19(6), 1277. <https://doi.org/10.3390/s19061277>
- Velik, R., Hoffmann, U., Zabaleta, H., Marti Masso, J. F., & Keller, T. (2012). The effect of visual cues on the number and duration of freezing episodes in Parkinson's patients. *Proc. Annu. Int. Conf. IEEE Eng. Med. Biol. Soc. EMBS*, 1, 4656–4659.