

## SENSORS AND DEVICES FOR RECEIVING HUMAN BIOSIGNALS

<sup>1</sup>Xakimjon N. Zaynidinov,

<sup>1</sup>The Tashkent University of Information Technologies

<sup>2</sup>Azambek A. Turakulov,

<sup>2</sup>The Namangan institute of Engineering and Technology.

<sup>2</sup>Fotima T. Mullajonova\*.

<sup>2</sup>The Namangan institute of Engineering and Technology.

\*e-mail: fmullajonova@mail.ru

### Abstract

In this article it is described some known methods and devices for detecting and taking biosignals (sphygm signals) at the radial artery which result from heartbeat. And also suggested some new methods and devices using a strain gauge, Hall magnetic sensor, laser distance measurer.

**Key words:** biosignals, radial pulse, pulse sensor, strain gauge sphygmography, methods of detecting and taking sphygm signals, heart rate sensor.

### Introduction

According to the World Health Organization, currently, the share of those who die because of cardiovascular diseases in the world is about 16 percent of the total number of deaths. In Uzbekistan, this share is almost 60 percent [1].

One of the main reasons for such a condition is that people do not resort to medical examination and diagnostics until the obvious symptoms of cardiovascular diseases are manifested. This, in turn, can also be caused by the fact that the monitoring of the cardiovascular system is carried out by highly qualified specialists in hospitals equipped with special devices. If people themselves, by some means, were able to predict their cardiovascular disease early, this would be the reason for turning to specialists before the outbreak, as a result of which it would be possible to prevent cases of untimely death.

The electrocardiogram (ECG), phonocardiogram (FCG) and sphygmogram (SFG) can be cited as examples of the means for monitoring the cardiovascular system.

The development of modern science and technology creates the opportunity to carry out the process of obtaining a sphygmogram from the above means by ordinary people who do not have medical knowledge with the help of pocket mobile devices, in everyday home and work conditions. And this can be the motivation to turn to specialists to carry out serious examinations at the right times, giving the opportunity to receive minimal, but important information, such as the frequency of heartbeats, rhythm, arterial blood pressure, the level of blood coagulability.

In this article, the technical tools (sensors) that can be used in such devices, the methods of their use in obtaining sphygmographic signals are discussed.

### Technical means and methods of obtaining sphygm signals.

Depending on the stroke of the arteries, the practice of assessing the activity of the heart and identifying (more precisely – guessing) various diseases has been used since ancient times [2,3]. At that time, the stroke was detected only by pressing the fingers of the hand to the place where the blood vessel of the human body passes near the skin, for example, the radial artery (the place of the thumb start of the forearm).

This method is one of the most convenient and easily carried out methods, which is still used in folk medicine, especially in Tibetan medicine today. In this method, the human fingers are used as a signal detection sensor and as. The brain of the same person is used as a means of signals processing. Consequently, the result is also known only to this person, there is no possibility of being watched, heard or read by others.

The first mechanical device, which allows people to visually see the results of a heartbeat, was discovered by the German scientist Karl von Vierordt in 1854 [4]. This device served to draw the process of beating the radial artery on a paper tape in the form of a sphygmograph.

Currently, there is an opportunity to improve such devices with the help of modern sensors. Conditionally, they can be divided into contact and non-contact types.

In contact devices, signals are generated as a result of the mechanical impact of the radial artery on the sensors. Such devices, in combination with the frequency of the heartbeat wave, give an opportunity to determine its amplitude, as well as the pressure that the sensor gives.

As for non-contact devices, signals are formed depending on the degree of transition of light or infrared light from one side of the body to the other side or measuring the time of return from the surface of the skin.

One of the advantages of non-contact devices is that, firstly, their dimensions can be quite small, so there is an opportunity to prepare the device in the size of an ordinary wristwatch. Secondly, the initial distance between the sensor and the object (wrist) does not effect the amount of signals. But such devices can not measure the force of a stroke. Therefore, they are mainly used to detect the frequency of heartbeat but not to receive sphygmographic signals.

Currently, the following contact sensors are mainly used.

**Sensor with a inductive coil** [5]. It takes heartbeat signals as a result of the impact of the radial artery to the magnetic core.

**Device with capacitive sensor** [6]. It works based on the change in the capacitance of the capacitor as a result of the moving skin touching plate by the radial artery.

**Device with piezoelectric sensor** [7]. The device uses a piezoelectric element that converts the pressure of the radial artery on the pellet into electricity.

**Device with strain gauge** [8]. This device is suggested by the authors of this article. It uses a strain gauge that converts the radial artery pressure on the plate into electricity.

Since the sensor works on the basis of mechanical pressure, it can measure not only the amplitude of the heartbeat wave, but also the force of the impact. This allows us to monitor blood pressure at the same time.

**Device with Hall magnetic sensor** [9]. This device is suggested by the authors of this article. The device uses the sensitivity of the Hall sensor 3 to the approach of a magnetized object 4 (Figure 1).

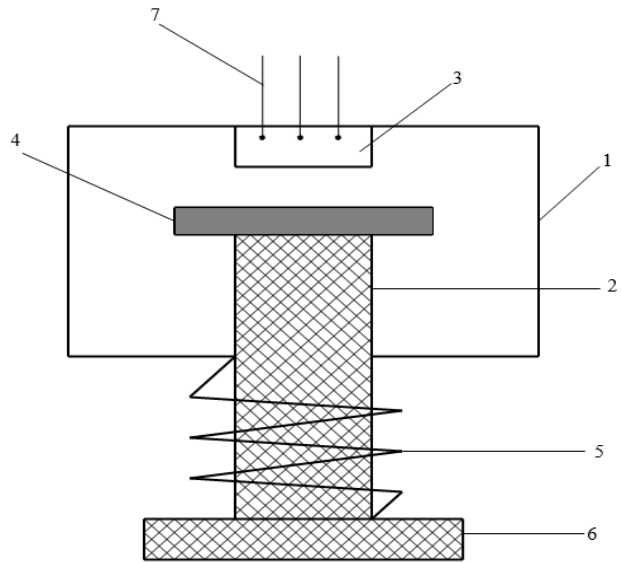

Figure 1. Scheme of the device using the Hall sensor. 1 – device case, 2 – pusher, 3 – Hall magnetik sensor, 4 – magnetized object, 5 – return spring, 6 – skin touching plate, 7-signal transmission cables.

As a result of the dilatation of the radial artery because of a heart beat, the skin touching plate 6 brings the magnetized object 4 closer to the Hall sensor 3, which generates a corresponding electrical signal.

As for non-contact devices, signals are formed depending on the degree of transition of light or infrared light from one side of the body to the other side or measuring the time of return from the surface of the skin.

One of the advantages of non-contact devices is that, firstly, their dimensions can be quite small, so there is an opportunity to prepare the device in the size of an ordinary wristwatch. Secondly, the initial distance between the sensor and the object (wrist) does not effect the amount of signals. But such devices can not measure the force of a stroke. Therefore, they are mainly used to detect the frequency of heartbeat but not to receive sphygmographic signals.

Currently, the following non-contact methods are mainly used.

**A method that uses the rate of light absorption** [10]. Devices using this method emit light from one side of a finger and receive it at the other side. Light receiving photoresistor determines the degree of absorption and so detects the heartbeat.

**Infrared (IR) heart rate sensors** [11]. This device sends IR ray to finger tip and receives reflexed from vessels ray. IR receiver gives electrical signal according to the reflexed ray quantity.

**A heart rate device with laser distance measurer** [12]. This device receives heart rate signals measuring distances from laser emitter to the radial artery (Figure 2).

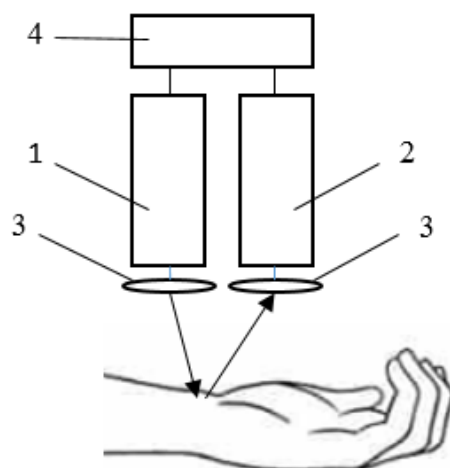

Figure 2. 1-Laser Beam Emitter, 2–laser beam receiver, 3-lens, 4-time interval measuring device.

When the heart beats (systole), the radial artery rises and the distance decreases. When the heart returns (diastole), the radial artery goes down and the distance increases. Using this phenomenon, the device creates a signal.

This method of heart rate monitoring is suggested by the authors of current article.

## CONCLUSIONS

As a result of using the above methods we have sphygmosignals as a finite numerical sequence of discrete analog signals suitable for processing. These numbers are the quantities of the amplitude at the time moments of the wave formed as a result of the beating of the human heart. As time moments they are taken the same time quantum limits, which are from the moment the sensors are launched until the next data request.

## References

1. <https://repost.uz/statistika-raznitsya>
2. Luisa María Arvide Cambra. THE EDITIONS AND THE TRANSLATIONS OF AVICENNA'S CANON OF MEDICINE. *Journal of Advances in Humanities*. 2016, Volume 4, Number 1.
3. О. В. Сорокин, Р. Манохар, А. С. Панова, М. А. Суботьялов. ЭТАПЫ СТАНОВЛЕНИЯ И РАЗВИТИЯ НАУЧНЫХ ПРЕДСТАВЛЕНИЙ О ДИАГНОСТИКЕ ПО ПУЛЬСУ. *Вестник Новосибирского государственного педагогического университета*. 2017, том 7, № 1. DOI: 10.15293/2226-3365.1701.11
4. R.E.Dudgeon. *The Sphygmography: its history and use as an aid to diagnosis in ordinary practice*. London, 1882.
5. Winncy Y. Du, *Resistive, Capacitive, Inductive, and Magnetic Sensor Technologies*, CRC Press, 2014 ISBN 1439812446, Chapter 4 Inductive Sensors
6. Larry K. Baxter (1996). *Capacitive Sensors*. John Wiley and Sons. p. 138. ISBN 978-0-7803-5351-0.
7. Gautschi, G. (2002). *Piezoelectric sensorics*. Springer Berlin, Heidelberg, New York. p. 3.
8. Piotr Tutak. APPLICATION OF STRAIN GAUGES IN MEASUREMENTS OF STRAIN DISTRIBUTION IN COMPLEX OBJECTS. *JACSM* 2014, Vol. 6, No. 2, pp. 135-145.
9. H. Heidari and V. Nabaei, "Magnetic sensors based on Hall effect," in *Magnetic Sensors for Biomedical Applications* (John Wiley & Sons, Inc., 2020), pp. 33–56.

10. Shirzadfar H, Ghaziasgar MS, Piri Z, et al. Heart beat rate monitoring using optical sensors. *Int J Biosen Bioelectron*. 2018;4(2):48–54. DOI: 10.15406/ijbsbe.2018.04.00097
11. Kaveh Bakhtiyari, Nils Beckman, Jürgen Ziegler. Contactless heart rate variability measurement by IR and 3D depth sensors with respiratory sinus arrhythmia. *Procedia Computer Science*. Volume 109, 2017, Pages 498-505
12. G. Berkovic & E. Shafir, "Optical methods for distance and displacement measurements," *Advances in Optics and Photonics* 4, pp. 441 -471, 11 Sep -2012.