

METHODS FOR REDUCING METAL OXIDATION WHEN MELTING ALUMINUM ALLOYS

TURAKHUDJAEVA SHIRINKHON

Turin Polytechnic University in Tashkent, 17,
Little Ring Road street, Tashkent, Uzbekistan

TURAKHUJAEVA AZIZAKHON,

Tashkent State Technical University,
Universitet Street, Tashkent, 100095, Uzbekistan,

SAIDMAKHAMADOV NOSIR,

Tashkent State Technical University,
Universitet Street, Tashkent, 100095, Uzbekistan,

AKRAMOV MUKHAMMADALI

Ferghana Polytechnic Institute, 86, Ferghana Street, Ferghana, Uzbekistan.

ABSTRACT

The process of melting and pouring aluminum alloys is usually carried out at a temperature range from 680 to 730 °C. However, due to the great relationship of aluminum and oxygen at these temperatures, strong oxidation of the metal and saturation of the melt with oxide inclusions occur. In recent years, technologies for melting aluminum alloys have been developed to reduce the oxidation of metal with oxygen. One of these new technologies is the melting and processing of aluminum alloy at temperatures using carbon as a reducing agent. This article reveals the results of the research on the development of flux composition for melting aluminum waste. The authors have demonstrated the melting unit diagram and the results of their studies on identification of the temperature mode for melting aluminum scrap. For electric unit with mobile and fixed electrodes, the modes for heating and loading metal and modes for melting aluminum and its waste have been given. The article describes the research results and recommendations, according to which the smelting chamber temperature must be maintained at 1,000-1,100 °C, and the melting zone temperature – at 1,400-1,500 °C. It is also recommended to load the aluminum waste after the flux melting and at flux temperature not less than 700-750 °C. Table 1 shows the flux compositions that allow for aluminum melting process in different melting units. In the conclusion, the authors state that the application of melting unit design in aggregate with graphite electrodes and protective flux provides: reduced irretrievable burn-off loss, reduced energy costs, and improved quality of the melt due to reduced content of oxide and gas inclusions in the melt composition [1-4].

KEYWORDS: process of melting, aluminum alloys, mechanical properties, oxygen, melt composition, metal.

INTRODUCTION

In the foundry industry, the main attention is paid to the quality of the obtained products. However, one of the features of the remelting metals and alloys, in particular aluminum, is a natural loss due to burn-off loss. Aluminum has great affinity with oxygen, which leads to increased losses during melting and overheating before pouring into the molds (Van Horn, 2007) [5].

Liquid aluminum melt is covered by the 0.2 mm oxide film within 0.1 seconds. Given that the melting process lasts for 40-50 minutes and the metal mirror is periodically stirred by incoming metal, the metal loss through burn-off becomes evident. In order to reduce metal losses due to burn-off of aluminum alloys, protective fluxes that protect the liquid melt from contact with oxygen are applied. However, the use of protective flux requires appropriate technology of smelting in the relevant design of melting unit [6-8].

EXPERIMENTAL PROCEDURE

The authors of the article have developed a method for remelting aluminum alloy under protective flux and created a unit for the method's implementation (Turakhodjaev et al., 2014, 2020). When developing this method, the data on electroslag remelting furnace application was referred to. A distinguishing feature of this furnace is its capability to process production waste in the form of slag. Experimental studies on remelting were carried out at the unit demonstrated in Figure 1. The installation is a single-phase unit and is powered by the welding machine TS-500 [9].

2.1 Determination of the flux composition during melting of aluminum alloys

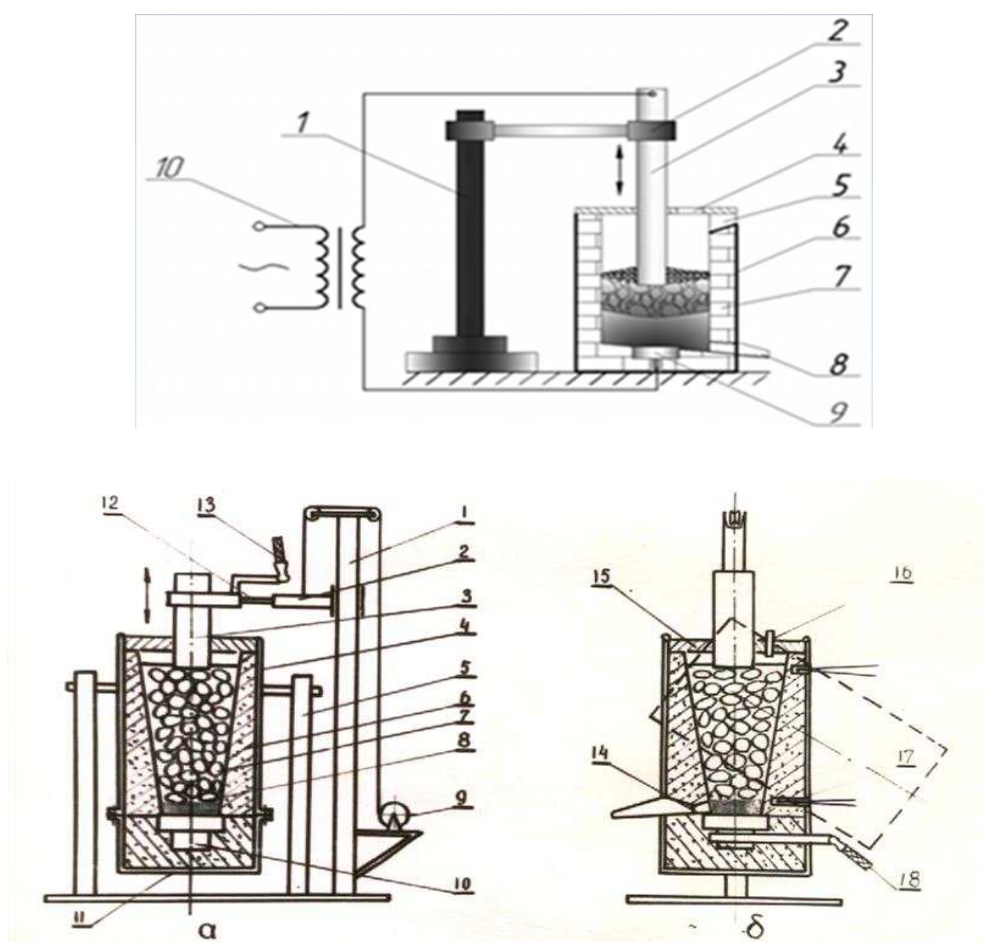

Figure 1. Installation for remelting aluminum scrap

The experimental installation (Figure 1) consists of: rack (1), along which the movement of an upper electrode (3) is performed; lever (2); shell (4) with a thickness of 4 mm, connected to the tray; rammed lining (6); two small racks (5) that retain the experimental installation and allow revolution through 180°. Below the furnace there is a lower electrode (10) that is isolated from the environment by rammed lining. Copper bus bars (18) and (13) are connected to the lower and upper electrodes by an insulating material (12).

The presence of the movable upper electrode is necessary because the electrical conductivity varies depending on slag, thus it is necessary to change the current path. The slag adjustment (8) takes place while the coke (7) is heated. After melting and metal tapping, the installation is switched off and rotated by 180°, and then slag and coke are removed. The top of the unit has two rotary domes, one of which has a hole (16) for gas outlet and sampling for further chemical analysis. To carry out the probing melts, it is necessary to create temperature mode that is provided by a closed circuit: the upper electrode – coke – the lower electrode. Under the influence of the passing current, the coke is heated up to the temperature of 1,400-1,500 °C (Turakhodjaev and andere, 2008-2020). As the coke is heated and its surface is burned, the charge level decreases, and the upper electrode is lowered.

After the coke is heated up to the sufficient temperature (for aluminum slag it is 700-750 °C), the flux is charged. The applied fluxes are effective only in combination with appropriate technology. For example, the use of (NaF+NaCl) alloys salts for fluxes results in structure refinements and improves the mechanical properties. For aluminum alloys refining, refining salts are used (zinc chloride ZnCl₂, magnesium chloride MgCl₂), which leads to the formation of gaseous AlCl₃ that is carried to the melt's surface. On the basis of the conducted experiments on the developed furnace, the following results to identify the flux composition were obtained during melting aluminum alloys supplying flux of various sizes to the surface of the working space. To reduce the flux loss through burn-off, the installation arc was blocked by the electrical conductivity of the coke in the contact mode. The temperature of the installation's working chamber was maintained at 1,000-1,100 °C, and melting zone temperature – at 1,400-1,500 °C. Loading was carried through the loading hole in the top of the unit. Loading of waste was performed after the melting and heating the flux up to 600-650 °C, 700-750 °C, 800-850 °C and 900-950 °C. As a result of experimental melts, the authors obtained data describing the impact of melting mode on the quality. Table 1 represents data on the flux composition, and Table 2 provides data on melting methods.

FLUX COMPOSITION

3.1 Table. Flux components

Flux components in percent by weight, %								
		NaCl	KCl	CaF ₂	MgCl ₂	CaCl ₂	NaF	BaCl ₂
Purpose								
1	Waste remelting	50	30	20	-	-	-	-
2	Waste remelting	50	20	20	-	-	-	-
3	Waste remelting	40	20	5	-	-	35	-
4	Waste remelting	50	30	10	-	-	-	10
5	Waste remelting	50	45	5	-	-	-	-
6	Waste remelting	40	40	10	-	-	10	-
7	Covering flux	40	-	20	10	30	-	-
Melting heat								
1	Specific heat of fusion, cal/g	123.5	74.1	-	70	54.2	27.8	-
2	Melting temperature, °C	804.3	790	1330	712	772	962	577
3	Density, g/cm ³	2.163	189	3.18	2.32	2.152	-	1.85

3.2 Table-. Melting methods

№	Refining procedure (increasing the density)	Means of increasing metal purity and density	Refining technology
1	Adsorption	Titanium chips	Mixing degreased chips for 5 minutes
2		Manganese chloride	Loading 0.2% MgCl ₂ in an alloying basket
3		Hexachloroethane	Modification by three portions (0.4%) in an alloying basket
4		Argon	Blowing through for 10 minutes
5		Multipurpose flux	Loading 2% flux composed of 50% NaCl, 30% NaF, 10% Na ₃ Al ₆ , 10% KCl, equalizing for 10 minutes
6		Active filter	Filtering during the flow from the furnace into the bale-out crucible through the 100 mm layer of flux composed of 52.7%, 47.3% NaF
7		Inert filter	Filtering through a SSFZ glass fiber
8	Non-adsorption	Ultrasound	Treatment (20 kHz) in two steps: the first – 10 minutes, equalizing – 10 minutes, the – second 10 minutes
9		Vacuum	Degassing at 10 mmHg for 15 minutes under a flux layer composed of 62% 13% 25% (0.2% flux)
10	Combined refining	Filtering through the active filter, and then degassing	-
11	Crystallization in autoclave	Pressure 0.5-0.6 MN/m ²	-
12	Electroslag remelting	Melting, overheating in the layer of liquid flux	Various NaCl, KCl NaCl+MnCl+KCl NaCl+NaF NaCl+KCl+NaF NaCl+KCl+NaF

In order to remove the contaminants, the same principle of metal melting is applied, but in this case, the heat source is slag bath resistance that heats slag to a predetermined temperature under the influence of an electric current passing through the slag [10-12].

RESULTS

When using aluminum waste melting process with formation of a liquid flux bath at a temperature of 600-650 °C, the content of oxide inclusions in the melt composition was 7-8%, the amount of hydrogen was 0.60-0.62 cm³ /100g. In the second mode of melting, which took place under protective flux layer at a temperature of 700-750 °C, the content of oxide inclusions in the melt composition was 2-3%, and the amount of hydrogen was 0.34-0.36 cm³ /100g. In the melting mode, which took place under a protective layer of flux at a temperature of 800-850 °C, the content of oxide inclusions in the melt amounted to 4-5%, and the amount of hydrogen was 0.42-0.44 cm³ /100g. In the melting mode, which took place under protective flux layer at 900-950 °C, the content of oxide inclusions in the melt composition was 6-7%, and the amount of hydrogen was 0.54-0.56 cm³ /100g. As is obvious from the results of studies, the temperature of the liquid flux bath for melting aluminum alloys affects the quantitative indicators of the oxide inclusions and included gas in the obtained melt (Turakhodjaev et al., “Change ...”, 2015). This data point to the effectiveness of melting under a protective flux cover in case if the appropriate temperature mode is

maintained. Table 3 shows the results of chemical analysis for the melt obtained after melting in the furnace in four modes.

Table 3. Chemical analysis of the melt after melting in four modes

№	Melting mode (temperature of the protective layer, °C)	Amount of aluminum oxide in the melt, %	Amount of hydrogen in the melt, cm ³ /100g
1	600-650	7-8	0.60-0.62
2	700-750	2-3	0.34-0.38
3	800-850	4-5	0.42-0.44
4	900-950	6-7	0.54-0.56

CONCLUSIONS

The following conclusions can be drawn on the basis of the research results. The use of protective flux layer at a temperature of 700-750 °C for melting aluminum alloys and waste provides:

- Reduced amount of oxide inclusions in the melt;
- Reduced amount of included gas in the melt;
- Improved quality of the produced melt due to reduced oxide and gas inclusions.

The advantages of applying the method of melting in electric furnace with electrodes:

- The need for a second installation for the slag preparation is eliminated;
- The burn-off loss during melting of the easily oxidizable charge is reduced;
- Any possible non-ferrous alloys can be melted by preparing an appropriate flux;
- Alloys with different chemical compositions and properties can be obtained when using various composition of the slag.

REFERENCES

- 1) Turakhodjayev Nodir Djahongirovich, Saidmaxamadov Nosir Muysinaliyevich. Important features of casting systems when casting alloy cast irons in sand-clay molds.//ACADEMICIA AnInternational Multidisciplinary Research Journal
- 2) Turakhodjayev Nodir, Saidmaxamadov Nosir Analysis of defects in white cast iron.// SOI: 1.1/TAS DOI: 10.15863/TAS International Scientific Journal Theoretical & Applied Science p-ISSN: 2308-4944 (print) e-ISSN: 2409-0085 (online) Year: 2020 Issue: 06 Volume: 86 Published: 30.06.2020 <http://T-Science.org>.
- 3) Turakhodjayev Nodir, Saidmaxamadov Nosir. Development of composition of wear-resistant white pig iron with a stable structure obtained by the casting method. ACADEMICIA An International Multidisciplinary Research Journal (Double Blind Ref ereed & Reviewed I nt erna t iona l J ourna l) ISSN: 2249-7137 Vol. 10, Issue 7, July 2020 Impact Factor: SJIF 2020 = 7.13
- 4) Turakhodjayev Nodir, Saidmaxamadov Nosir. Analysis of the chemical composition and microstructure of white cast iron.//EPRA International Journal of Multidisciplinary Research (IJMR) - Peer Reviewed Journal Volume: 6 | Issue: 8 | August 2020 || Journal DOI: 10.36713/epra2013 || SJIF Impact Factor: 7.032 ||ISI Value: 1.188
- 5) High-strength, ductility and modulus Al–Li/B4C composite with near nanostructure produced by accumulative roll bonding Wang Y., Zhong F., Wu R., Wu H., Turakhodjaev N., Kudratkhon B., Sun J., Hou L., Zhang J., Li X., Zhang M.2020 Journal of Alloys and Compounds 9258388

- 6) Concurrently improving uniform elongation and strength of ultrafine-grained Al-2Li alloy Wang Y., Zhang S., Wu R., Turakhodjaev N., Zhang J., Liu M., Mardonakulov S. 2020 Materials Science and Engineering A 9215093
- 7) Microstructure and mechanical properties of ultra-lightweight Mg-Li-Al/Al-Li composite produced by accumulative roll bonding at ambient temperature Wang Y., Liao Y., Wu R., Turakhodjaev N., Chen H., Zhang J., Zhang M., Mardonakulov S. 2020 Materials Science and Engineering A 9215093
- 8) Studying the scientific and technological bases for the processing of dumping copper and aluminum slags Nodir T., Sherzod T., Ruslan Z., Sarvar T., Azamat B. 2020 Journal of Critical Reviews 23945125
- 9) Ways to increase the strength of the surface of the parts Nodir T., Shukhrat C., Jamaliddin K., Bekzod Y., Jaloliddin E., Kulmukhammad C. 2020 Journal of Critical Reviews 23945125
- 10) Ways to increase the strength of shaftgear teeth working in a highly abrasive grinding environment Nodir T., Shukhrat C., Nargiza S., Kulmukhammad C. 2020 Journal of Critical Reviews 23945125
- 11) Analysis of technological solutions for reducing the copper concentration in slags from oxygen-flare smelting of copper sulfide concentrates Turakhodjaev N., Tursunbaev S., Tashbulatov S., Kuchkorova M. 2020 Journal of Critical Reviews 23945125
- 12) The transformation of LPSO type in Mg-4Y-2Er-2Zn-0.6Zr and its response to the mechanical properties and damping capacities Wang D., Wu H., Wu R., Wang Y., Zhang J., Betsofen S., Krit B., Hou L., Nodir T. 2020 Journal of Magnesium and Alloys 22139567