

# OVERVIEW OF SUPERCAPACITORS & BOOST CONVERTERS USED FOR HYBRID VEHICLE APPLICATIONS

Mrs. RASHMI P. BELOKAR

Department of Electronics and Telecommunication Engineering, MMCOE, Karvenagar, Pune

Mrs. REVATI M. JOSHI

Department of Electronics and Telecommunication Engineering, MMCOE, Karvenagar, Pune

P.R.CHOUBE

Department of Electrical Engineering, MMCOE, Karvenagar, Pune

## ABSTRACT:

This paper emphasizes association of supercapacitor and battery for ECCE hybrid vehicle. Basically ECCE vehicle is an vehicle developed at L2ES laboratory in collaboration with international research centre in French. The test bench made used lead acid batteries with a rated voltage of 540V, two motors were used, and one was coupled to alternator as a prime mover. The alternator power is then rectified to convert in to DC. The main aim of this paper is to study the power management which is been fed by two super-capacitors pack. While carrying out this experiment each supercapacitor module is of 108 cells with a peak voltage of 270V. The purpose of this experiment was to investigate innovating tests for hybrid vehicle applications.

**KEYWORDS:** Super-capacitors, Capacitor Charging Method, battery power management etc

## INTRODUCTION:

In the last three decade pollution levels and pollution awareness is been increased to great extent. It turned researchers to move to the other fuels than usage of fossil fuels, and the major cause of this is vehicle moving around the world. The vehicle manufactures took this matter very seriously and in nineties they started research based on alternative fuels e.g. CNG, electric vehicle. When adopting electric vehicle as a general mass commuter, the major problem was a weight and cost of the battery are still unresolved. The batteries are made to provide energy and high power during the transient states or moving uphill. These disadvantages of battery or electrical technology made them not a promising solution. As a solution super capacitors are adopted to supply the power in the peak period or transient states. In normal condition battery

power sufficient to power up the vehicle and keep it running.

## SUPER CAPACITORS:

Capacitors are energy storing element, charge stored in the capacitor is physical movement of electrons, no chemical reaction in been taking place while doing charging or discharging action. The charging and discharging process is highly reversible, moreover discharged cycle is continuous.

Now a day's electrochemical capacitors are developed are termed as (ECS), and this is been used in many application by carious manufactures. One of the prominent applications is usage of this in hybrid vehicle. Super capacitors are also called as ultra capacitors or electric double layer capacitor (EDLC). These capacitors have a advantage it can store more than 400 farad in a single case, and it is not possible to store this high amount of charge in any other available type.

## CONSTRUCTION OF SUPER CAPACITORS:

Super-capacitors are different in construction as compared to normal capacitors; the major difference is the electrodes used in these capacitors. Super capacitors used carbon (Nano- tube) technology. The carbon technology used in these virtually creates a very high surface area and very small distance between them. Super capacitor does not possess a dielectric material e.g. ceramic, polymer or may be an aluminum oxide for separation of the electrodes. Super capacitor physical barrier was made from activated carbon, so that when electrical charge is applied to the electrode, it generates double electric field is generated. Double electric generated in a super capacitor also acts like a dielectric medium. Virtually thickness of double dielectric layer is smaller than a length of molecule. Formed double

electric layer becomes a dielectric medium when voltage is applied and current begins to flow.

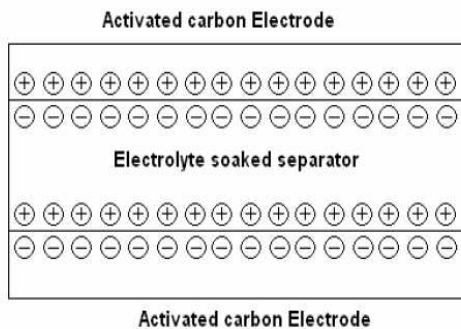

Fig. No.1. Construction of super capacitors

The double layers formed on the activated carbon surfaces can be illustrated as a series of parallel RC circuits. As shown below the capacitor is made up of a series of RC circuits where R1, R2 ...Rn are the internal resistances and C1, C2..., Cn are the electrostatic capacitances of the activated carbons.

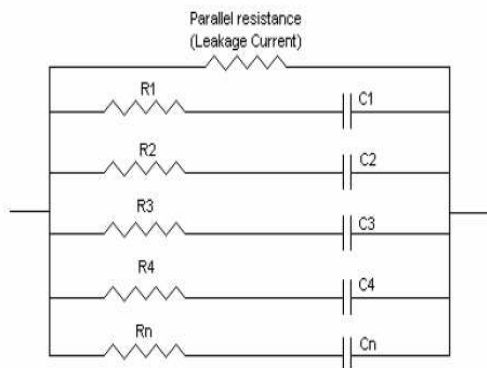

Fig. No.2. Equivalent demonstration of super capacitors

When voltage is applied current will start flowing through every RC circuit. The time required to charge the capacitor is depends on the value of circuit resistance and capacitance of each RC circuit. It can be easily interpreted that the larger the CR value the longer will be charging time of the capacitor. The current required for charging capacitor is given by

$$I_n = (V/R_n) \exp(-t / (C_n * R_n)) .$$

As author has stated earlier super capacitor is a double layer capacitor, the energy stored in super capacitor by charge transfer at the boundary at the electrode and electrolyte. A super capacitor is made up of two electrodes, a separator and an electrolyte. Both

the electrodes are made up of carbon particles which offer advantage of high surface area part.

**EQUIVALENT CIRCUIT:**

Supercapacitor can be demonstrated similarly to conventional film, ceramic or aluminum electrolytic capacitors

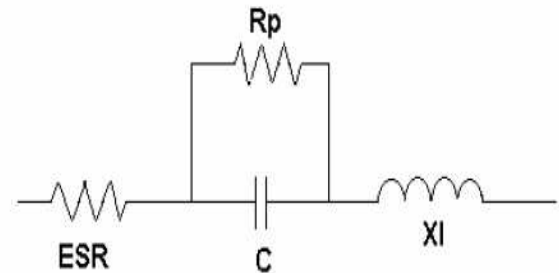

Fig. No.3. Equivalent circuit of super capacitors.

The equivalent circuit given in fig.no.2. is simplified or simple first order model of a supercapacitor. In practice super capacitors exhibit a non ideal behavior, because of usage of porous material for making electrodes. Because of this reason supercapacitor behave more like a transmission line in a power system network than a capacitor. Fig. No.4. gives more detail equivalent circuit of the supercapacitor.

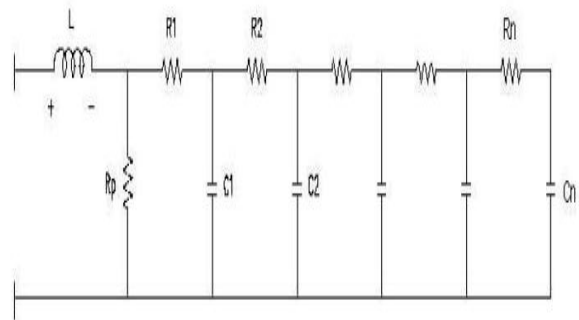

Fig. No.4. Detail equivalent circuit of the supercapacitor.

**Methods for measurement of capacitance**

There are a couple of ways used to measure the capacitance of supercapacitor.

1. Charge method
2. Charging and discharging method.

**Charge method**

Measurement is performed using a charge method using the following formula.

$$C = t/R$$

t= .632Vo where Vo is the applied voltage.

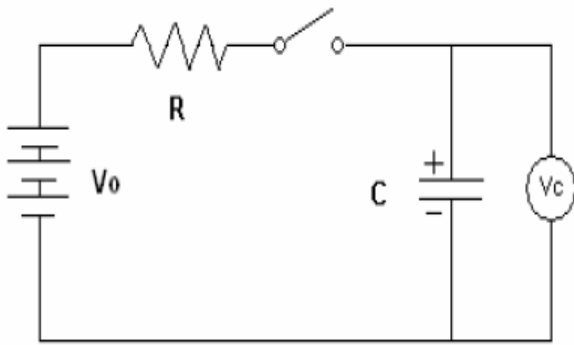

Fig. No.5 Circuit for charge and discharge method.

This method is similar to the charging method except the capacitance is calculated during the discharge cycle instead of the charging cycle.

Discharge time for constant current discharge

$$t = Cx (V_0 - V_1) / I$$

Discharge time for constant resistance discharge

$$t = CR \ln (V_0 / V_1)$$

Where  $t$  = discharge time,  $V_0$  = initial voltage,  $V_1$  = ending voltage,  $I$  = current.

#### CAPACITANCE :

As super capacitors possess large value of capacitance, the standard measuring instruments cannot be used for measurement of capacitance. Alternate methods are developed and detail procedure is mentioned below for measurement of capacitance of supercapacitor.

Procedure for measurement of capacitance of a supercapacitor:

1. Charge capacitor for 30 minutes at rated voltage.
2. Discharge capacitor through a constant current load.
3. Discharge rate to be 1mA/F.
4. Measure voltage drop between  $V_1$  to  $V_2$ .
5. Measure time for capacitor to discharge from  $V_1$  to  $V_2$ .
6. Calculate the capacitance using the following equation:

$$C = I * (T_2 - T_1) / (V_1 - V_2)$$

Where  $V_1 = 0.7V_r$ ,  $V_2 = 0.3V_r$  ( $V_r$  = rated voltage of capacitor)

#### ESR

AC ESR - Measure using a 4 probe impedance analyzer at 1 kHz.

DC ESR - measured using the following procedure

1. Charge capacitor using at a constant current.
2. After reaching rated voltage hold voltage for at least 1 minute.
3. Discharge capacitor at a rate of 1mA/F.
4. Measure the time it takes to have the voltage drop from  $V_1$  to  $V_2$ .

5. Calculate ESR using the following formula:

$$ESR (DC) = VI$$

#### LIFE EXPECTANCY :

The life expectancy of supercapacitor is identical to aluminum electrolytic capacitors. The life of supercapacitor will double for every 10°C decrease in the ambient temperature the capacitors are operated in. Supercapacitor operated at room temperature can have life expectancies of several years compared to operating the capacitors at their maximum rated temperature.

$$L_2 = L_1 * 2^{(T_m - T_a) / X}$$

$L_1$  = Load life rating of the super capacitor.

$L_2$  = expected life at operating condition.

$T_m$  = Maximum temperature rating of the supercapacitor.

$T_a$  = Ambient temperature the supercapacitor is going to be exposed to in the application.

#### BOOST CONVERTER:

A boost converter (step - up converter) is used in hybrid vehicle for boosting a power, its main work is to keep output voltage greater than the input voltage. It belongs to a class of switching mode power supply comprises of at least two semiconductor devices (diode, transistor) and at least one energy storing element (capacitor or inductors). Filter at output side is also added (sometimes a combination of inductors) are normally added to the output of the converter to reduce ripples on output side.

The operating principle that drives the boost converter is depends on the inductor for resisting changes in current. When being charged, it acts as a load and absorbs energy. While it is getting discharged, it acts as an energy source (similar to battery). The voltage it produces during the discharge phase is related rate of change of current, and not depends on the original charging voltage, thus it facilitates different input and output voltages.

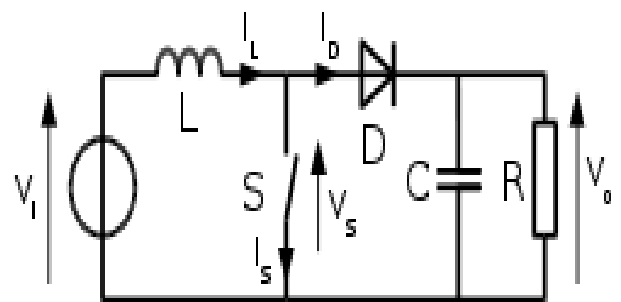

Fig. No.6.: Boost converter schematic

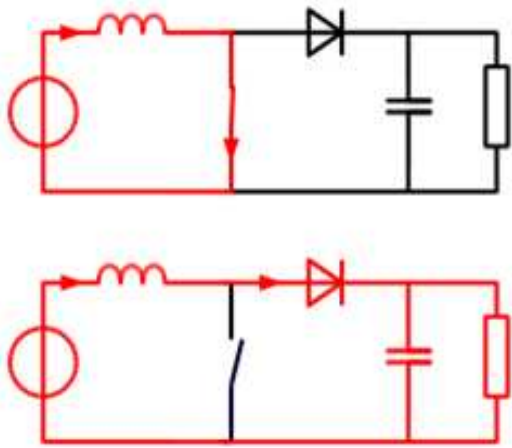

Fig. no.7. The two configurations of a boost converter, depending on the state of the switch S.

The basic principle of a Boost converter consists of 2 distinct states as shown in fig no.7.

1. Continuous mode
2. Discontinuous mode

**CONTINUOUS MODE:**

When a boost converter operates in continuous mode, the current through the inductor ( $I_L$ ) never falls to zero. Figure no.8. shows the typical waveforms of currents and voltages in a converter for operation in this mode. The output voltage can be calculated as follows, in the case of an ideal converter (i.e. using components with an ideal behavior) operating in steady conditions:

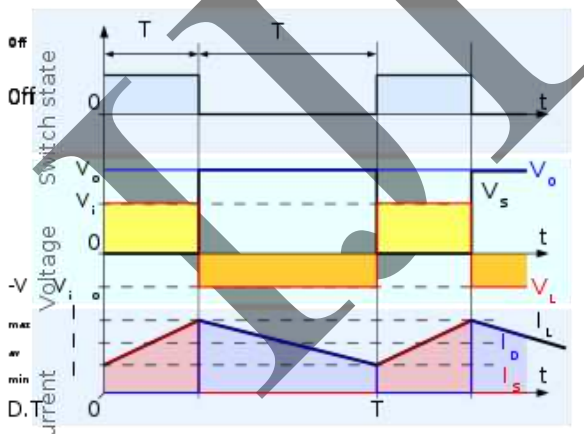

Fig. no.8. Waveforms of current and voltage in a boost converter operating in continuous mode.

**DISCONTINUOUS MODE:**

In some cases, the amount of energy required by the load is small to be transferred in a time smaller than the

whole commutation period. In this case, the current through the inductor falls to zero during first part of the period. The only difference in the principle described above is that the inductor is completely discharged at the end of the commutation cycle (see waveforms in fig. 9)

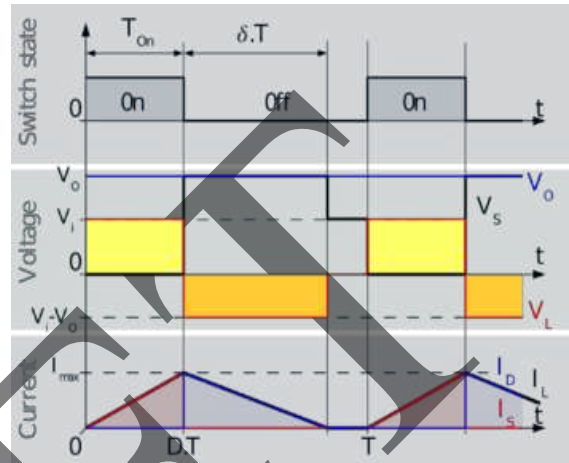

Fig no.9.: Waveforms of current and voltage in a boost converter operating in discontinuous mode.

**USES OF BOOST CONVERTER IN HYBRID VEHICLE:**

As a single battery cannot produce the more output voltage, so the battery systems are often stack cells in series for obtaining higher voltage. But it has a problem, stacking of too many cells will consume a large space. But if we use boost converter it will reduce the required number of cells for production of higher voltage.

The Toyota prius NHW20 hybrid vehicle model uses a 500V motor. If we supply a this high voltage without boost converter, the prius would need nearly 417 cells to power the motor. But in practice prius uses only 18 cells in conjunction with boost converter. In this case 202V from battery is been boosted to 500V.

**CONCLUSION AND FUTURE SCOPE OF WORK:**

In this paper author has written a detail construction and measurement techniques for measurement of capacitance. Super capacitors can be used for battery power management in electric hybrid vehicle, which is becoming popular amongst the people and researchers as a alternate source for fossil fuels.

**REFERENCES:**

[1] J.M Timmermans, P. Zadora, J. Cheng, Y. Van Mierlo, and Ph. Lataire. "Modelling and design of super capacitors as peak power unit for hybrid electric vehicles." Vehicle Power and Propulsion, IEEE Conference, 7-9 September, page 8pp, 2005.

- [2] Huang jen Chiu, Hsiu Ming Li-Wei Lin, and Ming-Hsiang Tseng. "A multiple- input dc/dc converter for renewable energy systems." ICIT2005, IEEE, 14-17 December, pages 1304–1308, 2005.
- [3] M.B. Camara, H. Gualous, F. Gustin, and A. Berthon. "Control strategy of hybrid sources for transport applications using supercapacitor and batteries." IPEMC2006, 13-16 August, Shanghai, P.R.CHINA, 1:1–5, 2006.
- [4] L. Solero, A. Lidozzi, and J.A. Pomilo. "Design of multiple-input power converter for hybrid vehicles." IEEE transactions on power electronics, 20, Issue 5, 2005.
- [5] Xin KONG and A. KHA. "Analysis and implementation of a high efficiency, interleaved current-fed full bridge converter for fuel cell system." IEEE, 28-01 Nov, 1:474–479, 2005.
- [6] M.B. Camara, F. Gustin, H. Gualous and A. Berthon. "Studies and realization of the buck-boost and full bridge converters with multi sources system for the hybrid vehicle applications." Second European Symposium on Super capacitors and Applications, ESSCAP2006, Lausanne, Switzerland, 2-3 November, 2006.
- [7] Huang-Jen Chiu, Hsiu-Ming, Li-Wei Lin, Ming-Hsiang Tseng. "A Multiple-Input DC/DC Converter for Renewable Energy Systems", *Industrial Technology*, ICIT2005, IEEE international Conference, 14-17 December 2005, Pages:1304-1308
- [8] LOUNIS Zohra. "APPOTS DES TECHNIQUES DE CABLAGES LAMINAIRES DANS UN ONDULEUR A IGBT DE MOYENNE PUISSANCE." PhD thesis, Institut National Polytechnique de Lorraine, 2000.
- [9] Seong-Jeub Jeon, Gyu-Hyeong Cho. "A Zero-Voltage and Zero-Current Switching Full Bridge DC-DC Converter With Transformer Isolation", IEEE Transactions on power Electronics, Vol.16, No.5, September 2001, Pages:573-580
- [10] Yungtaek Jabg, Milan M.Jovanovic, Yu-Ming Chang. "A New ZVS-PWM Full-Bridge Converter", IEEE Transactions on power Electronics, Vol.18, No.5, September 2003, Pages:1122-1129 Authorized