

A REVIEW OF IDENTIFICATION OF COULOMB, VISCOUS AND PARTICLE DAMPING PARAMETERS FROM THE RESPONSE OF SINGLE DEGREES OF FREEDOM SYSTEM

Prof.U.L.Anuse, Prof. D.N.Lawate

Assistant Professor, Department of Mechanical Engineering,
SVERI's College of Engineering Pandharpur, Maharashtra, India

ABSTRACT:

Mechanical vibration systems with viscous and Coulomb friction are of importance in the applications of dynamics and control problems. Friction dampers are used in gas turbine engines, high speed turbo pumps, large space structures which are flexible in nature and placed under carriage of railway bogie, vehicle suspension systems etc. These dampers are used for reduction of resonant stresses by usage sliding contact in between two points experiencing relative motion due to vibration, thereby dissipating resonant vibration energy.

Keywords: Friction dampers, Viscous and Coulomb Damping, Particle Vibration Damping, Response of a single degree of freedom.

INTRODUCTION:

When a vibrating system is damped with more than one type of models of damping, it is necessary to determine which of these types of damping are more effective to control the resonant response. In this type of cases, identification of damping parameters is very important. Therefore when a system may get damped because of application of Coulomb friction or even may be viscous friction, it is necessary to develop theoretical and experimental techniques for classification of these damping parameters from the responses of the vibrating system.

As such, it is proposed to develop techniques for identification of Coulomb and viscous friction (and also with particle damping) parameters responsible for the control of resonant response of vibrating systems.

METHODS OF VIBRATION CONTROL:

The problem of reduction in level of vibration in dynamic systems comes up mainly due to increase in operating speeds of the machines, large dimensions of constructions, more strict standards and norms by the environmental pollution boards and technological

demands placed on keeping vibrations as low as possible and at par with acceptance level. The important ways and means of controlling unacceptable vibrations in machines are:

I) SYSTEM MODIFICATION: Changing the rigidity (stiffness) and or inertial parameters (mass, inertia) to modify natural frequency or frequencies of the dynamic systems.

II) VIBRATION ISOLATION: Use of isolation techniques in which either the source of vibration is physically separated from the system (force transmissibility case) or a device is protected from the point of assembly joint (motion transmissibility case). The isolation systems can be passive, semi-active or active.

III) DYNAMIC VIBRATION ABSORBER: A dynamic Vibration absorber is simplest device used to reduce the steady state vibrations of a system at a certain fixed frequency of excitation. It is a passive control device which is attached to a vibrating body, subjected to force or motion of excitation.

IV) METHODS OF DAMPING: Damping used is viscous damping, visco-elastic damping, magneto-rheological damping, piezoelectric damping, electro-rheological damping, eddy current damping, and Particle damping etc. Active, semi-active and passive damping techniques are common methods of attenuating the resonant amplitudes excited of a structure or machine. Active damping techniques are not applicable under all circumstances due to power requirements, environment, cost, etc. under such circumstances passive damping techniques are a viable alternatively.

a) VISCOUS AND COULOMB DAMPING:

Various forms of passive damping exist, including viscous damping, viscoelastic damping, friction damping, and impact damping etc. Viscous and viscoelastic

damping usually have a relatively strong dependence on temperature. Friction while applicable over wide temperature ranges may degrade with wear.

Mechanical vibration systems with viscous and Coulomb friction hold great importance in the applications of dynamics and control problems. Coulomb damping and viscous damping are the two most important sources of energy dissipation in mechanical systems. It is important in practice to examine the dynamic characteristics of a servo-mechanism and a machine tool slide-way considering the influence of the friction. [1]

Two common classes of friction dampers have been considered in past studies. The first is viscous friction in which the frictional force is proportional with velocity of mass or "seismic element". It is still frequently assumed that the response of an actual vibration instrument is identical with the response of an ideal instrument in which damping is entirely "Viscous". However, the actual response may differ significantly from ideal response if the damping varies with other than the first power of the velocity, or is dependent on displacement, or if any appreciable amount of Coulomb damping is present. This last type of damping, sometimes typically known as Dry friction used to describe simple "Coulomb friction". Coulomb friction model assumes that the friction force is constant in magnitude and is directed so as to oppose relative movement of two surfaces in contact. The amplitude of friction force is proportional to the normal connecting force with a factor μ defined as the coefficient of friction.

b) PARTICLE DAMPING:

Particle damping technique is a derivative of impact damping with several advantages, Particle dampers significantly reduce the noise and impact forces generated by an impact damper and are less sensitive to changes in the cavity dimensions or excitation amplitude[2] the advantages of impact damper is that these dampers are inexpensive, simple designs that provide effective damping performance over a wide range of accelerations and frequencies. In addition, impact dampers are robust and can operate in environments that are too harsh for other traditional damping methods. Vibration damping with impact dampers has been used in a wide variety of applications including vibration attenuation of cutting tools, turbine blades, television aerials, structures, plates, tubing, and shafts. [3]

Particle Vibration Damping (PVD for the short) is a combination of impact damping and friction damping. In a PVD, metal or ceramic particles or powders of small size (0.05 to 5 mm in diameter) are placed inside cavities within or attached to the vibrating structure. Metal particles of high density such as lead or tungsten give high damping performance due to dissipation of kinetic energy. Particle Vibration Damping involves the potential energy absorptions and dissipation through momentum exchange between moving particles and vibrating walls, friction impact restitution. [4]

Particle Impact Damping (PID for the short) is a means for achieving high structural damping by the use of a particle-filled enclosure attached to the structure in a region of high displacements. The particles absorb kinetic energy of the structure and convert it into heat through inelastic collisions between the particles and the enclosure, and amongst the particles.

LITERATURE REVIEW:

Following are some of the important reviews of different researchers and scientists in the Vibration field.

Hundal [1]: This author have studied the system called base excitation frictional oscillator as drawn in figure no.1, the main aim of this study is to produce analytical solutions of the motion equation and at the end of the study same has been produced with strong mathematical proof. Utmost care has been taken to produce results in non-dimensional form for the reason as magnification factors versus frequency ratios as functions of Viscous and Coulomb friction parameters. As shown in figure no.1. The mass motion cannot be one stop or even a continuous during each cycle, and it depends on the system parameters. At conclusion the author was successful to find the response of a single degree of freedom during each cycle with coulomb and viscous types of friction, provided with harmonic base excitation.

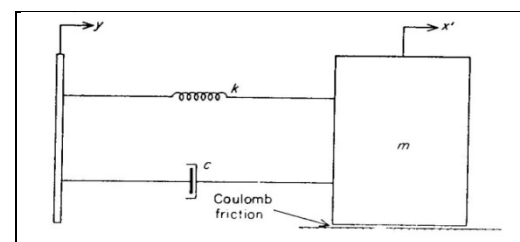

Fig. No. 1. System with Coulomb friction between mass and ground, with harmonic excitation of the base analyzed by Hundal [1]

Ferri and Dowell [2]: This paper is written in aim to investigate the vibration response of both single and multi-degree-of-freedom systems with combined dry friction and viscous damping. And authors were very successful in terms of accuracy, and fast analysis of the any given system.

Chen and Tomlinson [3] have proposed estimating damping parameters in nonlinear oscillators by using the displacement, acceleration and velocity output and formulating the output in terms of series of frequency response functions. A new type of time series model, the AVD model which accommodates the Acceleration, Velocity and Displacement simultaneously, has been used to estimate the characteristics of nonlinear single and multi-degree of freedom systems with dry Coulomb friction and Viscous damping. Numerical results via simulation are compared with those from a Fourier transform method, which has been suggested that the AVD model is a powerful technique for nonlinear system parameter identification.

Marui and Kato: Have worked out a brief analytical technique for the behavior of the linear forced vibratory system under the pressure of a Coulomb friction force, as shown in figure 2. Using this technique, the behavior of the system in the low exciting frequency range, where the remarkable pressure of friction easily develops, has been examined and the results have been compared with the experimental ones. The behavior of the system has been completely determined by the three non-dimensional parameters of non-dimensional frictional force, frequency ratio and damping ratio.

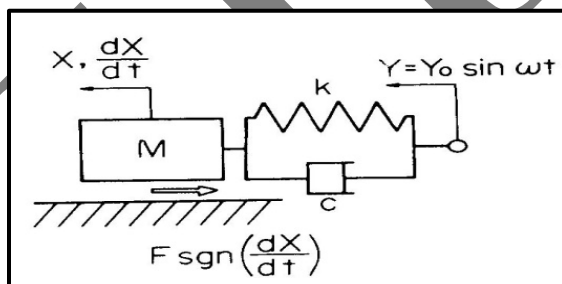

Fig.No.2 Forced vibratory system with Coulomb friction [6]

Liang and Feeny[5]: Have presented a method for estimating Coulomb and Viscous friction coefficients from responses of a harmonically excited dual-damped oscillator with linear stiffness. The identification method has been based on existing analytical solutions of non-sticking responses excited near resonance. The method

has been applicable if the damping ratio of viscous component can be considered small.

The Coulomb and Viscous friction parameters can be extracted from two or more input-output amplitude pairs at resonance. The method has been also tested numerically and experimentally. Experimental results have been cross checked with estimations from free-vibration decrements and also from friction measurements. A schematic diagram depicting S.D.O.F oscillator with viscous, Coulomb friction and base excitation has been shown in figure 3.

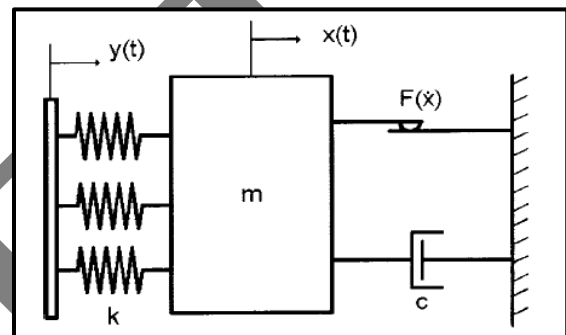

Fig.No.3 Schematic diagram depicting a S.D.O.F oscillator with viscous, Coulomb friction and base excitation [1]

Cheng and Zu[4]: Have studied a mass-spring oscillator damped with both Coulomb and Viscous friction and subjected to two harmonic excitations with different frequencies. By employing an analytical approach, closed form solutions for steady state response have been derived for both non-stop and one-stop motion. From numerical simulations, it has been found that near the resonance, the dynamic response due to the two-frequency excitation demonstrates characteristics significantly different from those due to a single frequency excitation. In addition, the one-stop motion has been demonstrated peculiar characteristics, different from those in the non-stop motion.

Mao et al [6] have examined the characteristics of Particle damping with respect to a simple single-mass impact damper and a dry-friction damper. The analysis of the damping characteristics of particle vibration dampers based on the 3D discrete element method has been carried out. The model of a single degree of freedom system of a particle vibration damper is as shown in figure 4.

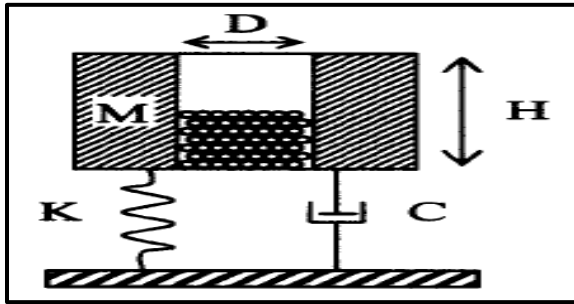

Fig. No.4. the model of a single degree of freedom system of a particle Vibration damper [6]

- 4) Chen, Q., and Tomlinson, G. R., 1996, "Parametric Identification Systems with Dry Friction and Nonlinear Stiffness Using a Time Series Model," ASME J. Vib. Acoust., 118, pp. 252–263.
- 5) J.W. Liang, and B.F. Feeny, 1999, "The Estimation of Viscous and Coulomb Damping in Harmonically Excited Oscillators," Proceedings of DETC 99, Las Vegas, Nevada, pp.1-8.
- 6) Gong Cheng, and Jean W. Zu, 2002, "Two-Frequency Oscillation with Combined Coulomb and Viscous Frictions," ASME J. Vib. Acoust., 124, pp. 537–544.

CONCLUSION:

It is seen that the identification and estimation of the numerous forms of damping present in a dynamic system is quite helpful in improvement of control of resonant response. As such, some theoretical and experimental studies on "Development of Theoretical and Experimental Methods for Identification of Coulomb, Viscous and Particle Damping Parameters from the Responses of a S.D.O.F Harmonically Forced Linear Oscillator" have been carried out.

The unique aspect of PID is that high damping has been achieved by absorbing the kinetic energy of the structure as opposed to the more traditional methods of damping uses elastic, where strain energy stored in the structure is converted to heat. From above literature study, it is necessary to understand contents of viscous damping, Coulomb damping and Particle damping in a system. The dominant damping identification in a system is useful to understand the behavior of system.

REFERENCES:

- 1) Hundal, M. S., 1979, "Response of a Base Excited System with Coulomb and Viscous Friction," J. Sound Vib., 64, pp. 371–378.
- 2) Ferri, A. A., and Dowell, E. H., 1988, "Frequency Domain Solutions to Multi-Degree-of-Freedom, Dry Friction Damped Systems," J. Sound Vib., 124, pp. 207–224.
- 3) Liang and B.F. Feeny, 2004, "Identifying Coulomb and Visco Friction in Forced Dual-Damped Oscillators," ASME J. Vib. Acoust., 126, pp. 118–125.