

# Bluetooth Controlled Metal Detector Robot

Ananya Bhattacharyya

Department of Electrical and Electronics Engineering, Assam Don Bosco University,  
Airport Road, Azara, Guwahati -781017, Assam, INDIA.  
ananyabhattacha@gmail.com

**Abstract:** *This paper presents a new type of robot that uses a metal detector sensor to detect metallic object passing over the metal detector. The robotic vehicle is controlled using android application for metal detection operation controlled with the help of Bluetooth technology. This project can be widely used because of its simplicity and ability to modify to meet changes of needs. Based on experimental studies, it was found that the mobile controlled robot can move in any direction as per the desired instruction and the beeper in the metal detector circuit beeps whenever it encounters any metallic object.*

**Keywords:** Arduino UNO, Bluetooth Module HC-05, Metal Detector, Motor Driver, Android Application

## 1. Introduction

In today's modern environment, almost everybody uses smartphones, which are a part of their day-to-day life. This project was about robotic movement control through smartphones. Many researchers [1] have developed such robotic movement control system using smartphones. Here, we aim to make a robot and to connect the metal detector circuit to it.

Here, a dedicated application has been created to control robotic hardware, which controls the movement of the robot. The embedded hardware has been developed on ATmega328P microcontroller and controlled by an Android smartphone. This controller receives the commands from the Android phone, takes the data and controls the motors of the robot by the motor driver L293D. The robot can able to move forward, backward, left and right movements. The Smartphone is been interfaced to the device by using Bluetooth. A Bluetooth device HC-05 module was used with Arduino UNO to receive commands from the smartphone. A metal detector circuit was connected to the robot to detect the metal. A beep sound was made when it detected the metal.

## 2. Methodology

This work is divided into two sections- hardware and software. Hardware section contains robot making, metal detector, and control unit. In the hardware section, we explain the working of Arduino and DC motors and how the robot utilizes them to detect the metallic obstacles. In the section of the metal detector, we describe general information about kind of metal detector and working principles. In the section of the control

unit, we describe what kind of microcontroller we use. While in the software section, we explain the algorithm that we use in making the android application and metal detector.

A simple block diagram is shown in Figure 1 below.

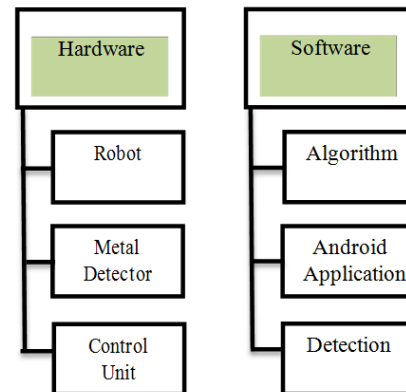
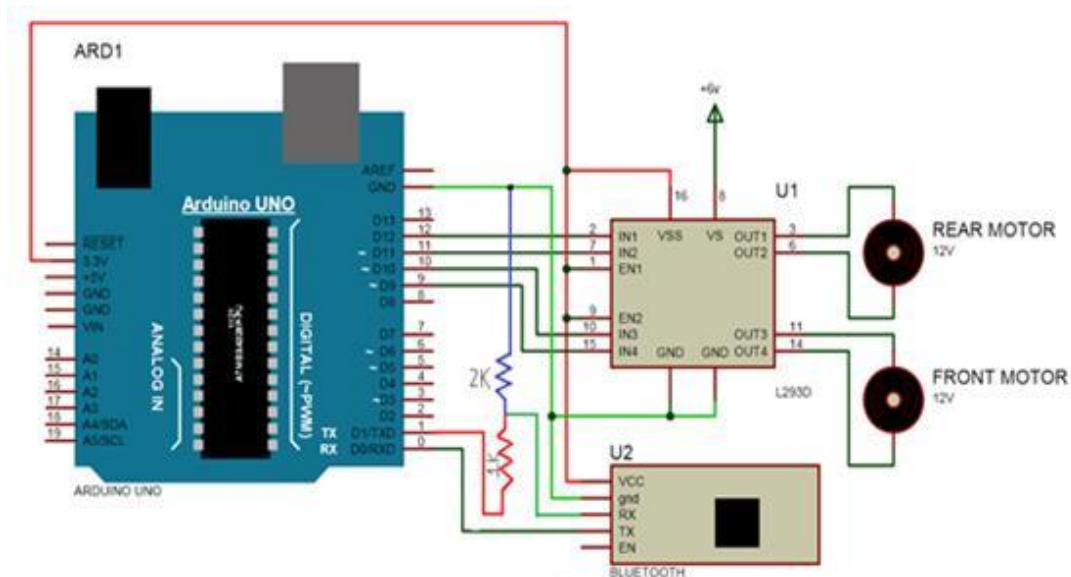

Figure 1: Working Sections in this work

## 3. Hardware Design

Hardware design consists of the Bluetooth controlled robot and the metal detector circuit. In this work, we utilized the components to build a configurability robot to reach our goal.

The circuit for Bluetooth controlled metal detector robotic car is shown in Figure 2. The Motor driver is connected to Arduino to run the car. Motor driver's input pins 2,7,10 and 15, are connected to Arduino digital pin numbers 12, 11, 10 and 9 respectively. Here we have used two DC motors to drive a car in which one motor is connected at the output pin of motor driver-3 and 6; and another motor is connected to pins- 11



**Figure 2:** Robotic Vehicle Circuit using Arduino UNO

and 14. A 9V battery is also used to power the motor driver for driving motors. The Rx pin of the Bluetooth module is connected to a voltage divider. From the voltage divider, one end is connected to the Tx pin of the Arduino and the other end is connected to the ground (GND) pin of the Arduino. Then the Tx pin of the module is connected to the Rx pin of the Arduino.

**3.1 Robotic vehicle circuit**

The robotic vehicle consists of Arduino UNO, Bluetooth Module HC-05, Metal Detector, Motor Driver and two DC Motors. The Vcc and ground pin of Bluetooth module is connected to 3.3V and ground of Arduino. A 9V battery is also used for power the circuit at Arduino  $V_{in}$  pin.

**3.1 Metal detector**

In this work, we mainly depend on a metal detector, because we need to decide the object is metallic or non-metallic. A metal detector device detects the presence of metal nearby. It takes advantage of the electric and magnetic properties of metals (Eddy currents) to detect metals [2].

The circuit for the metal detector circuit is shown in Figure 3, whose working is as follows.

Here the circuit is divided into three parts, an astable multivibrator, an LC circuit, and a comparator circuit. In the first stage i.e., the astable multivibrator circuit (using NE 555 IC), by giving a supply to the circuit it produces a frequency (say  $f_1$ ) and this frequency is fixed by adjusting the variable resistor R1 and R2 which are of the value 2K and 25K respectively. It produces a square wave at the output pin (i.e. pin 3) of the IC and is adjusted to give a frequency of 0.7 MHz.

In the second stage is the LC circuit. The inductance (L) here is a copper coil. When a metal is kept near to the coil, the electromagnetic field in the coil is disturbed which produces a frequency (say  $f_2$ ). The frequencies  $f_1$  and  $f_2$  meet at a junction. If frequency  $f_1$  is greater or lesser than  $f_2$ , it produces a voltage V, the voltage flows through the diodes. The negative voltage flows through diode D1, which is in reverse bias that is connected to the ground and it gets neutralize here. Whereas, the positive voltage flows through diode D2 which is in forward bias. The capacitor C5 reduces the

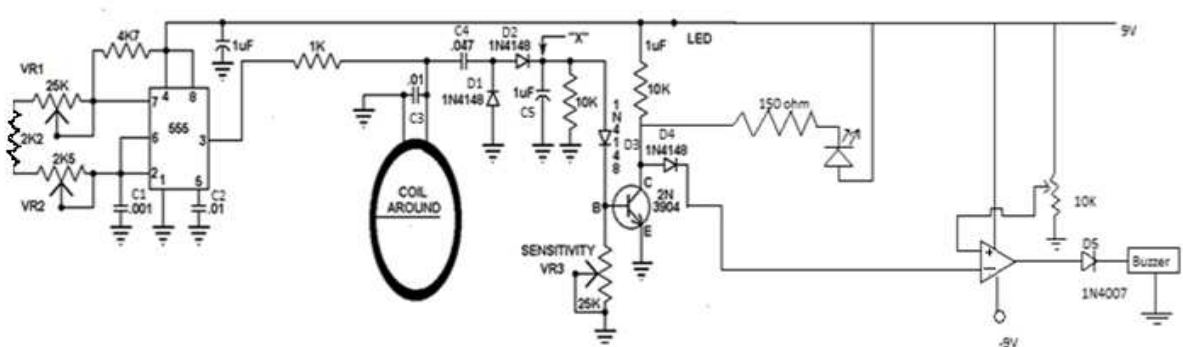

**Figure 3:** Robotic Vehicle Circuit using Arduino UNO

ripples in the voltage. Whenever the voltage flows through diode D3, if there is any negative voltage, it will be blocked by the diode and only positive voltage is allowed to pass which then flows to the NPN transistor. The transistor will be switched ON and a positive voltage will flow through diode D4; and then a positive voltage will flow to the pin 2 of the op-amp in the comparator circuit, which is in inverting mode. Here a variable resistor is connected to pin 3 of the op-amp, which sets the reference voltage of the comparator circuit. Here the voltage at pin 2 will be lower than the reference voltage at pin 3, so the output at pin 6 (output pin) will be high and a voltage from the op-amp will flow to diode D5 and then to the buzzer and the buzzer will beep.

However, when there is no metal near the coil, frequency  $f_1$  will be equal to  $f_2$ , the voltage produced at the junction will be zero, and hence there will be no voltage flowing across the circuit. The input at pin 2 will be more than the reference voltage, so the output will be low, therefore the buzzer will not beep.

### 3.3 Control Units (Arduino UNO, ATmega328P Microcontroller)

The Arduino Uno is the main hardware control unit, which is a microcontroller board and is based on the ATmega328P. It has 14 digital input/output pins, 6 analog inputs, a 16 MHz quartz crystal, a USB connection, a power jack, an ICSP header and a reset button [3]. It contains everything that is needed to support the microcontroller; simply it needs to be connected to a computer with a USB cable or power it with an AC-to-DC adapter or battery, to get started.

## 4. Software Design

In this section, algorithms used in making the android application and metal detection, have been briefly explained. Here, we utilized the advantages of an Android smartphone. The software components have been described with more details.

### 4.1 Algorithm

The general algorithm has the main steps to accomplish the general tasks, which are “start”, “stop” and “detection of metal”. The program will begin with the “start” step where the Bluetooth module HC-05 connected to Arduino Uno will pair with the android application. The robot moves as per the instruction, given by the Android Application. During this step, the robot moves and the metal detector checks if the object is a metallic object or not through passing it over the metal detector. In case, if a metallic object is countered by the metal detector, a beep sound will be produced by the beeper and the movement of the robot can be stopped. Otherwise, the robot will travel until it finds any metallic object, or else the movement robot can be stopped.

### 4.2 Android Application

Android is a very familiar word in today’s world. Millions of devices are running on Android OS and millions are being developed every day [4]. **App Inventor** is an application originally provided by Google and now maintained by the Massachusetts Institute of Technology (MIT). It allows anyone to create software applications for the Android Operating System (OS). It uses a graphical interface that allows users to create an application

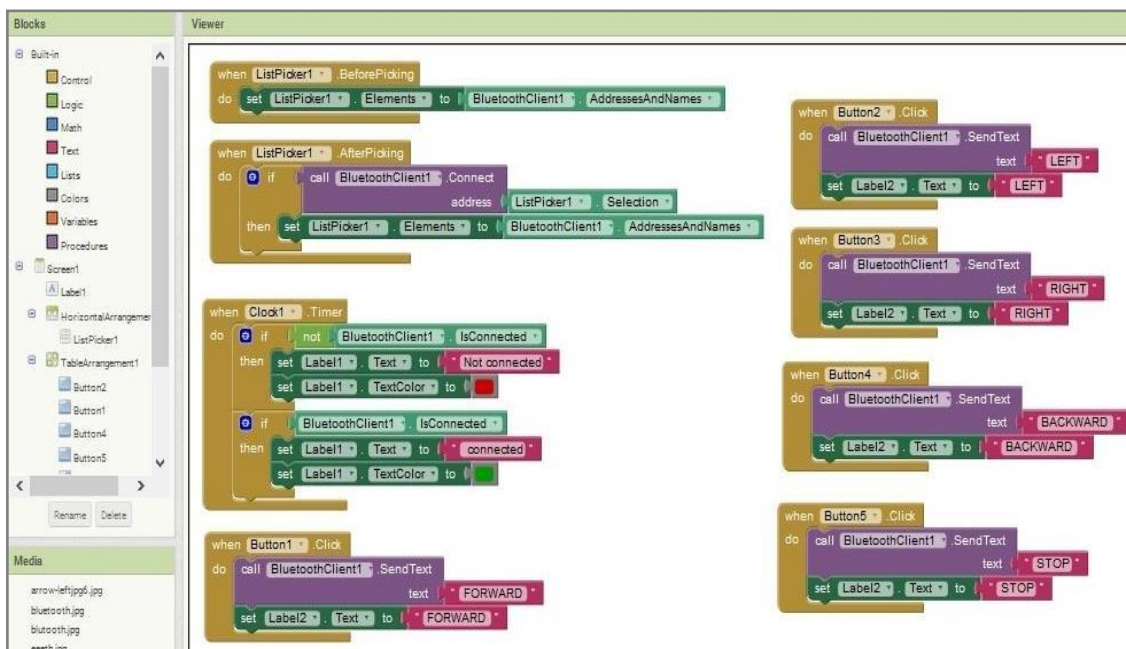
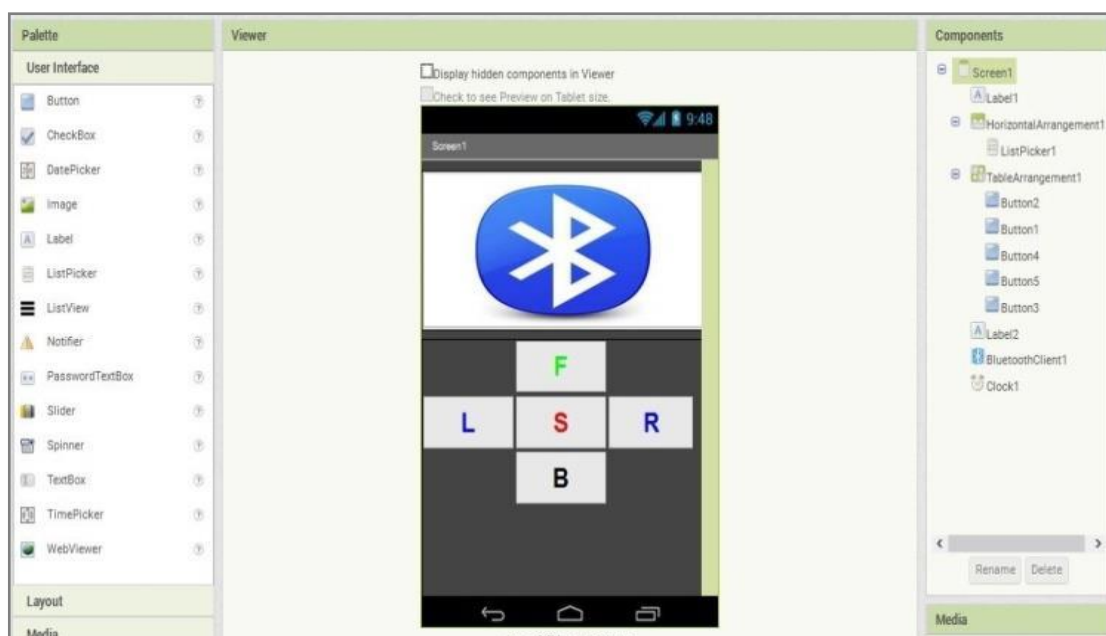

Figure 4: App Inventor Designer



**Figure 5:** Apps Inventor Block Editor

that can run on the Android system, which runs on many Android phones [5].

The first phase of application design goes through the **App Inventor Designer**, which is accessible through the web page. The left side of the window consists of ingredients like a screen, buttons, text boxes, images, labels and many more and the right side of the designer allows users to view the screen and components added to the screen.

In this app development, the **App Inventor** provides a versatile opportunity to develop a customized application that starts with establishing a Bluetooth connection by searching the available Bluetooth devices and make pair with them. For robotic movement, a character is assigned for each operation such as Forward-“F”, Backward-“B”, Left-“L” and Right-“R”.

#### 4.3 Detection

This task completely depends on the metal detector. Whenever the metal detector comes across and metal, it detects the metal by making a beep sound.

### 5. Operation of the System

The project is designed to control a metal detector robotic vehicle using an android application. Bluetooth device is interfaced to the control unit for sensing the signals that are transmitted by the android application. This data is conveyed to the control unit, which moves the robot. An

ATmega328P microcontroller is used in this project as a control device.

Remote operation is achieved by any smartphone with Android OS, upon a GUI (Graphical User Interface) based touch screen operation. We used the HC-05 module to pair the Android application to the robot. The motors are interfaced to the control unit through motor driver L293D IC. An extra metal detector circuit is connected to the robot to detect the metal efficiently.

### 6. Conclusion and future scope

This project presents a metal detecting robot using Bluetooth communication with Bluetooth module HC-05. The robot is moved in a particular direction with the help of Bluetooth technology, controlled by our mobile. Experimental work has been carried out successfully. The result shows that higher efficiency is achieved using the embedded system. This proposed method is verified to be highly beneficial for many purposes [6]. The metal detector worked at a constant speed without any problem. In this project, we also achieved wireless communication between the robot and the Android application.

This project can be further developed by enhancing the performance and by adding more features. Further developments in this project can be an addition of features like the addition of a gas sensor, connecting robotic arms for pick and place purposes etc.

## References

- [1] A. R. Yeole, S. M. Bramhankar, M. D. Wani and M. P. Mahajan, "Smart Phone Controlled Robot Using ATMEGA328 Microcontroller", *International Journal of Innovative Research in Computer and Communication Engineering (IJIRCCE)*, Vol. 3, Issue 1, Jan. 2015, pp. 353-356. Retrieved from [http://www.ijircce.com/upload/2015/january/31\\_Smart.pdf](http://www.ijircce.com/upload/2015/january/31_Smart.pdf)
- [2] H. Alsahafi, M. Almaleky and T. M. Sobh, "Design and Implementation of Metallic Waste Collection Robot", *Presentation at Faculty Research Day*, School of Engineering, University of Bridgeport, Bridgeport, 28 March 2014. Retrieved from <https://scholarworks.bridgeport.edu/xmlui/handle/123456789/558>
- [3] P. Kumar and P. Kumar, "Arduino Based Wireless Intrusion Detection Using IR Sensor and GSM", *International Journal of Computer Science and Mobile Computing (IJCSMC)*, Vol. 2, Issue 5, May 2013, pp. 417-424. Retrieved from <https://pdfs.semanticscholar.org/b60e/75e252a4cdf4e708e73af1e12f869208b6f9.pdf>
- [4] J. K. Winter, *Android Controlled Mobile Robot*, Final Year Project Report, Industrial Engineering, Department of Systems Engineering and Automation, Universidad Carlos III de Madrid, July 2013, Madrid. Retrieved from [http://wiki.asrob.uc3m.es/images/1/1d/PFC\\_-\\_Jorge\\_Kazacos.pdf](http://wiki.asrob.uc3m.es/images/1/1d/PFC_-_Jorge_Kazacos.pdf)
- [5] M. Selvam, "Smart Phone Based Robotic Control for Surveillance Applications", *International Journal of Research in Engineering and Technology (IJRET)*, Vol. 3, Issue 3, March 2014, pp. 229-232. Retrieved from <https://doi.org/10.15623/ijret.2014.0303043>
- [6] H. Aoyama, K. Ishikawa, J. Seki, M. Okamura, S. Ishimura and Y. Satsumi, "Development of Mine Detection Robot System", *International Journal of Advanced Robotic Systems*, Vol. 4, Issue 2, June 2007, pp. 229-236. Doi: <https://doi.org/10.5772/5693>