

IoT Based Industrial Production Monitoring System Using Wireless Sensor Networks

P. Sumithra¹, R. Nagarajan², M. Padmavathi³, M. Malarvizhi⁴

¹PG Scholar, ²Professor, ³Assistant Professor, ⁴Professor,
Department of Electrical and Electronics Engineering, Gnanamani College of Technology, Namakkal, Tamilnadu, India
Email:krmaga71@yahoo.com

Abstract— *The objective of the work is to monitoring the production lines in industry using wireless sensor networks. This work presents the benefits of an automated data collection and display system for production lines. It involves wireless sensor networks for monitoring the productions in industry. Condition monitoring reduces human inspection requirements through automated monitoring, reduces maintenance through detecting faults before they escalate and improves safety and reliability. This work can monitor productions using temperature, voltage and current sensors with support of microcontroller. The relay is acts like a switch to monitor the production lines. In this work, Global System for Mobile communication technique is used to transferring the collected data. The collection of data, it is transferred into computerize spreadsheet in the remote office by authorized personnel for reporting purpose. The system will generate an automated report which stays in place and the management only needs to act base on the results. This work is cost effective automatic data collection is the alternative to manual data collection. It significantly improves the accuracy of the valuable reports for the management. It also reduces the time for identifying the fault using this technique*

Keywords—*Global System, Microcontroller, Wireless Sensor Networks.*

I. INTRODUCTION

In this modern world multinational business companies were increasing rapidly. The Single businessman wants to monitor all the production Status in each industry with manual presence. In this work the business man can monitors all the production status through PC or Mobile in the corporate office itself. Mobile phones have become a widespread means of communication. It becomes a part of everyday life with ever more people enjoying the service and extra freedom they provide. It works on the basis of Global System for Mobile Communication [1]. A subscriber from any systems can access telecommunication services by using a subscriber identity

module card in a handset suitable for the network on the visited system [2].

The short message service allows text messages to be sent and received to and from mobile telephones. The text can comprise words or numbers or an alphanumeric combination. Because simple person to person messaging is such an important component of total SMS traffic volumes, anything that simplifies message generation as well as extended utility of the SMS being sent is an important enabler of short message service. Such extended utility of SMS fulfills certain important requirements. This system is developed to control the functions of a device from a remote area through the SMS of a mobile phone using Microcontroller [3], [4].

The monitoring systems equipped with sensors and wireless communication can reduce the costs to a small percentage of conventional monitoring systems, and will increase its field of application. Due to the detailed information of the structural behavior of bridges obtained from the monitoring system, maintenance costs could also be reduced, since inspection methods can be applied more efficiently [5]. Only after certain changes in the structural behavior have been identified, will inspection be necessary, and proper repair could be done immediately after the occurrence of the defect. This reduces the risk of further damage. The analysis of measured data and the knowledge of continuous changes of structural behavior will improve the life time prognosis of civil structures, and reduce the overall maintenance costs of buildings and transport networks. The data has to be continuously transmitted to the supervisor. Each sensor device which is itself a complete, small measurement and communication system has to be powered and cost optimized. Using multi-hop techniques, the data of the sensor network can be transmitted over short distances of some 10 m from each hop to a base station on site. At the base station the data items are collected and stored in a database for subsequent analysis. This data can then be accessed by a remote user. If the central unit detects a hazardous condition by analyzing the data, it raises an alarm message [6], [7].

The central unit also allows for wireless administration, calibration and reprogramming of the sensor nodes in order to keep the whole system flexible. Each mote is composed of one or more sensors, a data acquisition and processing unit, a wireless transceiver and a battery power supply. The acquisition and processing unit usually is equipped with a low power microcontroller offering an integrated analogue to digital converter and sufficient data memory to store the measurements. This unit also incorporates signal conditioning circuitry interfacing the sensors to the ADC [8].

The advancement in wireless communications and electronics has enabled the development of low-cost sensor networks. The sensor networks can be used for various application areas. For different application areas; there are different technical issues that researchers are currently resolving. The current state of art-sensor networks is captured in this article, where solutions are discussed under their related protocol stack layer sections. This article also points out the open research issues and intends to spark new interests and developments in this field [9].

II. PROPOSED SYSTEM

The electronic system need low voltage DC power supply in different electronic circuits operated in different power supplies, the ratings depending upon load current and voltage. The load current depending on load resistance i.e load current is inversely proportional to load resistance. So the matched designation of power supply is very important to every electronic circuit [10]. In this circuits need two power supplies .All ICs are worked on regulated DC power 5v with GND. The relay derive worked on dc 12v with GND .This unit consist of transformer, rectifier, filter and regulator.

The AC voltage typically 230v RMS is connected to a transformer which steps that AC voltage down to the level of the desired AC voltage [11], [12].

The diode rectifier then provides a bridge rectified voltage that is initially filtered by a simple capacitor filter to produce a DC voltage. This resulting DC voltage usually has some ripple or Ac voltage variations. The regulator circuit can use this DC input to provide DC voltage that not only has much less ripple voltage but also remains the same DC value even the DC voltage varies somewhat the load connected to the output DC voltages changes. The Dc level obtained from a sinusoidal input can be improved 100% using a process called full wave rectification. It uses 4 diodes in a bridge configuration. From the basic bridge configuration the two diodes (say D2 & D3) are conducting while the other two diodes (D1 & D4) are in “off” state during the period $t = 0$ to $T/2$. Accordingly for the negative of the input the conducting diodes are D1&D4. Thus the polarity across the load is the same. The Figure1 shows the proposed system circuit diagram.

The filter circuit used here is the capacitor filter circuit where a capacitor is connected at the rectifier output, and a DC is obtained across it .The filtered waveform is essentially a DC voltage with negligible ripples, which is ultimately fed to the load. The output voltage from the capacitor is more filtered and finally regulated. The voltage regulator is a device, which maintains the output voltage constant irrespective of the changes in supply variations, load variation and temperature changes. Here we use one fixed voltage regulator namely LM7805.The IC 7805 is a+5 voltage regulator [13].

This powerful 200 nanosecond instruction execution yet easy-to-program only 35 single word instructions CMOS FLASH-based 8-bit microcontroller packs Microchip's powerful PIC architecture into a 40 package and is upwards compatible with the PIC16C5X, PIC12CXXX and PIC16C7X devices. The PIC16F877A features 256 bytes of EEPROM data memory, self programming, an ICD, 2Comparators, 8channels of10-bit Analog-to-Digital converter, 2 capture/compare/PWM functions, the synchronous serial port can be configured as either 3-wire Serial Peripheral Interface or the 2-wire Inter-Integrated Circuit bus and a Universal Asynchronous Receiver Transmitter [14].

The program memory contains the programs that are written by the user. The program counter executes these stored commands one by one. Usually PIC16F877 devices have a 13 bit wide program counter that is capable of addressing $8K \times 14$ bit program memory space. This memory is primarily used for storing the programs that are written to be used by the PIC. These devices also have $8K \times 14$ bits of flash memory that can be electrically

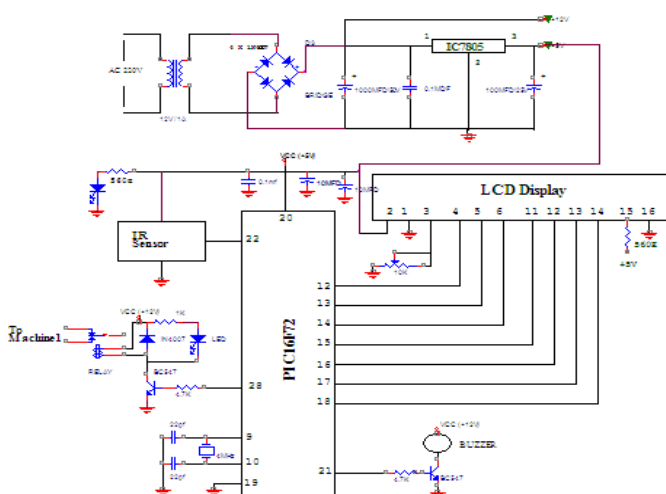

Fig.1: Proposed System Circuit Diagram

erasable/reprogrammed. Each time write a new program to the controller, we must delete the old one at that time. The banked arrangement is necessary because there are only 7 bits are available in the instruction word for the addressing of a register, which gives only 128 addresses [15].

TO-220 Power Package (T)

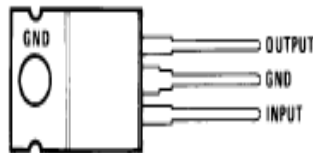

Fig.2: Voltage Regulator

The selection of the banks are determined by control bits RP1, RP0 in the STATUS registers Together the RP1, RP0 and the specified 7 bits effectively form a 9 bit address. The first 32 locations of Banks 1 and 2, and the first 16 locations of Banks 2 and 3 are reserved for the mapping of the Special Function Registers. The EEPROM data memory allows single-byte read and writes. The Flash program memory allows single-word reads and four-word block writes. Program memory write operations automatically perform an erase-before write on blocks of four words. A byte write in data EEPROM memory automatically erases the location and writes the new data. The write time is controlled by an on-chip timer. The write/erase voltages are generated by an on-chip charge pump, rated to operate over the voltage range of the device for byte or word operations [16]. Figure 2 shows voltage regulator.

The LM341 and LM78MXX series of three-terminal positive voltage regulators employ built-in current limiting, thermal shutdown, and safe-operating area protection which make them virtually immune to damage from output overloads. With adequate heat sinking, they can deliver in excess of 0.5A output current. Typical applications would include local (on-card) regulators which can eliminate the noise and degraded performance associated with single-point regulation [17].

The relay is an electrical switch that opens and closes under control of another electrical circuit. In the original form, the switch is operated by an electromagnet to open or close one or many sets of contacts. It was invented by Joseph Henry in 1835. Because a relay is able to control an output circuit of higher power than the input circuit, it can be considered, in a broad sense, to be a form of electrical amplifier [18]. When a current flows through the coil, the resulting magnetic field attracts an armature that is mechanically linked to a moving contact. The movement either makes or breaks a connection with a

fixed contact. When the current to the coil is switched off, the armature is returned by a force approximately half as long as the magnetic force to its relaxed position. Usually this is a spring, but gravity is also used commonly in industrial motor starters. Most relays are manufactured to operate quickly. In a low voltage application, this is to reduce noise [19].

In a high voltage or high current application, this is to reduce arcing. If the coil is energized with DC, a diode is frequently installed across the coil, to dissipate the energy from the collapsing magnetic field at deactivation, which would otherwise generate a spike of voltage and might cause damage to circuit components. If the coil is designed to be energized with AC, a small copper ring can be crimped to the end of the solenoid. This "shading ring" creates a small out-of-phase current, which increases the minimum pull on the armature during the AC cycle [20], [21].

III. SOFTWARE IMPLEMENTATION

MPLAB is a Windows program package that makes writing and developing a program easier. It could best be described as developing environment for some standard program language that is intended for programming a PC computer. Some operations which were done from the instruction line with a large number of parameters until the discovery of IDE "Integrated Development Environment" are now made easier by using the MPLAB [22]. [23]. Still, our tastes differ, so even today some programmers prefer the standard editors and compilers from instruction line. In any case, the written program is legible, and well documented help is also available.

- Grouping the projects files into one project (Project Manager)
- Generating and processing a program (Text Editor)
- Simulator of the written program used for simulating program

Requirements

- PC compatible computer 486 or higher
- Microsoft Windows 3.1x or Windows 95 and new versions of the Windows
- Operating system.
- VGA graphic card
- 8MB memory (32MB recommended).
- 20MB space on hard disc
- Mouse

Hitech c

The HI-TECH C Compiler is a set of software, which translates programs written in the C language to executable machine code programs. Versions are available which compile programs for operation under the host operating system, or which produce programs for

execution in embedded systems without an operating system [24].

Features

1. A single batch file or command file will compile, assemble and link entire programs.
2. The compiler performs strong type checking and issues warnings about various constructs which may represent programming errors.
3. The generated code is extremely small and fast in execution.
4. A full run-time library is provided implementing all standard C input/output and other functions.
5. The source code for all run-time routines is provided.
6. A powerful general purpose macro assembler is included. Programs may be generated to execute under the host operating system, or customized for installation in ROM.

Security systems:

Cameras can be installed at various locations in the shopping center with each camera covering a specific range of area and with the help of the GSM remote control the entire shopping center can be monitored from one location. The range of vision can be changed by controlling the angle of camera by the remote control. Such type of security system can also be used to provide security in homes, banks, research labs etc [25].

Temperature Monitoring:

In hospitals, it is very important to maintain an optimum temperature in the Operation Theater, the I.C.U and the morgue. In such cases, Internet remote control can be used to adjust the air conditioner settings and thus continuously monitor the temperature from any location. Such remote temperature monitoring is also useful in the case of sterilizing medical equipment, as also for food preservation, in blood banks etc [26].

Process Control:

In large Aquaculture centers, the GSM controlled system has been used to monitor and control important parameters such as temperature of water, pH and oxygen content, using different types of sensors. This can be expanded to processes which require careful monitoring like those for extracting medicines, fluids using microorganisms, etc. In industries and offices, this remote control system can be used to control various machines or appliances from any location and thus helps in automation of the system. SMS stands for Short Message Service. It is a technology that enables the sending and receiving of messages between mobile phones. SMS first appeared in Europe in 1992. It was included in the GSM (Global System for Mobile Communications) standards right at the beginning. Later it was ported to wireless technologies like CDMA and TDMA. The GSM and SMS standards

were originally developed by ETSI. ETSI is the abbreviation for European Telecommunications Standards Institute [27], [28].

Now the 3GPP (Third Generation Partnership Project) is responsible for the development and maintenance of the GSM and SMS standards. As suggested by the name "Short Message Service", the data that can be held by an SMS message is very limited. One SMS message can contain at most 140 bytes (1120 bits) of data, so one SMS message can contain up to: 160 characters if 7-bit character encoding is used. (7-bit character encoding is suitable for encoding Latin characters like English alphabets.) 70 characters if 16-bit Unicode UCS2 character encoding is used. (SMS text messages containing non-Latin characters like Chinese characters should use 16-bit character encoding.) SMS text messaging supports languages internationally. The burden in a CT metering circuit is essentially the amount of impedance (largely resistive) present [29].

Typical burden ratings for IEC CTs are 1.5VA, 3VA, 5VA, 10VA, 15VA, 20VA, 30VA, 45VA & 60VA with ANSI/IEEE B-0.1, B-0.2, B-0.5, B-1.0, B-2.0 and B-4.0. This means a CT with a burden rating of B-0.2 can tolerate up to 0.2 Ω of impedance in the metering circuit before its output current is no longer a fixed ratio to the primary current. Items that contribute to the burden of a current measurement circuit are switch blocks meters and intermediate conductors. The most common source of excess burden in a current measurement circuit is the conductor between the meter and the CT. Often, substation meters are located significant distances from the meter cabinets and the excessive length of small gauge conductor creates a large resistance. This problem can be solved by using CT with 1 ampere secondary's which will produce less voltage drop between a CT and its metering devices (used for remote measurement) [30].

Rating factor is a factor by which the nominal full load current of a CT can be multiplied to determine its absolute maximum measurable primary current. Conversely, the minimum primary current a CT can accurately measure is "light load," or 10% of the nominal current (there are, however, special CTs designed to measure accurately currents as small as 2% of the nominal current). The rating factor of a CT is largely dependent upon ambient temperature. Most CTs have rating factors for 35 degrees Celsius and 55 degrees Celsius. It works fine with all languages supported by Unicode, including Arabic, Chinese, Japanese and Korean. Besides text, SMS messages can also carry binary data.

It is possible to send ringtones, pictures, operator logos, wallpapers, animations, business cards (e.g. VCards) and WAP configurations to a mobile phone with

SMS messages. One major advantage of SMS is that it is supported by 100% GSM mobile phones. Almost all subscription plans provided by wireless carriers include inexpensive SMS messaging service. Unlike SMS, mobile technologies such as WAP and mobile Java are not supported on many old mobile phone models. GSM-900 uses 890–915 MHz to send information from the mobile station to the base station (uplink) and 935–960 MHz for the other direction (downlink), providing 124 RF channels (channel numbers 1 to 124) spaced at 200 kHz. Duplex spacing of 45 MHz is used. In some countries the GSM-900 band has been extended to cover a larger frequency range. This 'extended GSM', E-GSM, uses 880–915 MHz (uplink) and 925–960 MHz (downlink), adding 50 channels (channel numbers 975 to 1023 and 0) to the original GSM-900 band. Time division multiplexing is used to allow eight full-rate or sixteen half-rate speech channels per radio frequency channel. There are eight radio timeslots (giving eight burst periods) grouped into what is called a TDMA frame. Half rate channels use alternate frames in the same timeslot. The channel data rate for all 8 channels is 270.833 kbit/s, and the frame duration is 4.615 ms. The transmission power in the handset is limited to a maximum of 2 watts in GSM850/900 and 1 watt in GSM1800/1900 [31].

The GSM has used a variety of voice codecs to squeeze 3.1 kHz audio into between 5.6 and 13 kbit/s. Originally, two codecs, named after the types of data channel they were allocated, were used, called Half Rate (5.6 kbit/s) and Full Rate (13 kbit/s). These used a system based upon linear predictive coding (LPC). In addition to being efficient with bitrates, these codecs also made it easier to identify more important parts of the audio, allowing the air interface layer to prioritize and better protect these parts of the signal. GSM was further enhanced in 1997 [12] with the Enhanced Full Rate (EFR) codec, a 12.2 kbit/s codec that uses a full rate channel. Finally, with the development of UMTS, EFR was refactored into a variable-rate codec called AMR-Narrowband, which is high quality and robust against interference when used on full rate channels, and less robust but still relatively high quality when used in good radio conditions on half-rate channels. There are five different cell sizes in a GSM network—macro, micro, pico, femto and umbrella cells. The coverage area of each cell varies according to the implementation environment. Macro cells can be regarded as cells where the base station antenna is installed on a mast or a building above average roof top level. Micro cells are cells whose antenna height is under average roof top level; they are typically used in urban areas. Picocells are small cells whose coverage diameter is a few dozen meters; they are mainly used indoors. Femtocells are cells designed for use in residential or small business

environments and connect to the service provider's network via a broadband internet connection. Umbrella cells are used to cover shadowed regions of smaller cells and fill in gaps in coverage between those cells [32].

The cell horizontal radius varies depending on antenna height, antenna gain and propagation conditions from a couple of hundred meters to several tens of kilometers. The longest distance the GSM specification supports in practical use is 35 kilometers (22 mi). There are also several implementations of the concept of an extended cell, where the cell radius could be double or even more, depending on the antenna system, the type of terrain and the timing advance. Indoor coverage is also supported by GSM and may be achieved by using an indoor picocell base station, or an indoor repeater with distributed indoor antennas fed through power splitters, to deliver the radio signals from an antenna outdoors to the separate indoor distributed antenna system. These are typically deployed when a lot of call capacity is needed indoors, for example in shopping centers or airports. However, this is not a prerequisite, since indoor coverage is also provided by in-building penetration of the radio signals from nearby cells. The modulation used in GSM is Gaussian minimum-shift keying (GMSK), a kind of continuous-phase frequency shift keying. In GMSK, the signal to be modulated onto the carrier is first smoothed with a Gaussian low-pass filter prior to being fed to a frequency modulator, which greatly reduces the interference to neighboring channels (adjacent channel interference) [33], [34].

IV. NETWORK STRUCTURE

The network behind the GSM system seen by the customer is large and complicated in order to provide all of the services which are required. It is divided into a number of sections and these are each covered in separate articles.

- The Base Station Subsystem (the base stations and their controllers)
- The Network and Switching Subsystem (the part of the network most similar to a fixed network). This is sometimes also just called the core network.
- The GPRS Core Network (the optional part which allows packet based Internet connections).
- All of the elements in the system combine to produce many GSM services such as voice calls and SMS.

The circuit is designed to control the buzzer. The buzzer ON and OFF is controlled by the pair of switching transistors (BC 547). The buzzer is connected in the Q2 transistor collector terminal. When high pulse signal is given to base of the Q1 transistors, the transistor is

conducting and close the collector and emitter terminal so zero signals is given to base of the Q2 transistor. Hence Q2 transistor and buzzer is turned OFF state. When low pulse is given to base of transistor Q1 transistor, the transistor is turned OFF. Now 12v is given to base of Q2 transistor so the transistor is conducting and buzzer is energized and produces the sound signal [35], [36].

One of the SMS technology is that one SMS message can only carry a very limited amount of data. To overcome this drawback, an extension called concatenated SMS (also known as long SMS) was developed. A concatenated SMS text message can contain more than 160 English characters. Concatenated SMS works like this: The sender's mobile phone breaks down a long message into smaller parts and sends each of them as a single SMS message. When these SMS messages reach the destination, the recipient mobile phone will combine them back to one long message. The drawback of concatenated SMS is that it is less widely supported than SMS on wireless devices [37]-[39].

V. RESULTS AND DISCUSSION

IOT Output



Fig.3: Login Screen



Fig.4: Monitor Screen

The Figure 3 shows login screen. An LCD consists of two glass panels, with the liquid crystal material sandwiched in between them. The inner surface of the glass plates are coated with transparent electrodes which define the character, symbols or patterns to be displayed. Polymeric layers are present in between the electrodes and the liquid crystal, which makes the liquid crystal molecules to maintain a defined orientation angle. The Figure 4 shows monitor screen. One each polariser is

placed outside the two glass panels. These polarisers would rotate the light rays passing through them to a definite angle, in a particular direction. When the LCD is in the off state, light rays are rotated by the two polarisers and the liquid crystal, such that the light rays come out of the LCD without any orientation, and hence the LCD appears transparent. When sufficient voltage is applied to the electrodes, the liquid crystal molecules would be aligned in a specific direction. The light rays passing through the LCD would be rotated by the polarisers, which would result in activating / highlighting the desired characters.

The LCD's are lightweight with only a few millimetres thickness. Since the LCD's consume less power, they are compatible with low power electronic circuits, and can be powered for long durations. The LCD's don't generate light and so light is needed to read the display. By using backlighting, reading is possible in the dark. The LCD's have long life and a wide operating temperature range. Changing the display size or the layout size is relatively simple which makes the LCD's more customer friendly. The LCDs used exclusively in watches, calculators and measuring instruments are the simple seven-segment displays, having a limited amount of numeric data. The recent advances in technology have resulted in better legibility, more information displaying capability and a wider temperature range. These have resulted in the LCDs being extensively used in telecommunications and entertainment electronics. The LCDs have even started replacing the cathode ray tubes (CRTs) used for the display of text and graphics, and also in small TV applications.

VI. CONCLUSION

The Production monitoring system developed is an essential production tool in industries for both the management and the production team. The Production monitoring system captures and distributes unadulterated production information at all levels along the production process without human intervention. The data collected is crucial and this could be collected by using a real time production monitoring system. With the collected data, realistic production goals can be achieved when proper analysis is done and implementation is practiced. Events occurring can also be displayed with the help of a Production monitoring system. Production faults can be rectified instantly. A Production monitoring system enables the production team to operate efficiently optimizing all available resources towards a better production in the above sequence that it is clearly a Production monitoring system along the production of the human intervention data information of real time production hardware modules collected data

REFERENCES

- [1] Design and prototype of a six-legged walking insect robot Servet Soyguder and H asan Alli Mechanical Engineering Department, Firat Un iversity, Elazig, Turkey Industrial Robot: An International l Journal Volume 34 · Number 5 · 2007 · 412–422
- [2] R.Nagarajan and M,Saravanan, “Performance Analysis of Multicarrier PWM Strategies for Cascaded Multilevel Inverter,” European Journal of Scientific Research (EJSR), Vol.92 No.4, pp. 608-625, Dec. 2012.
- [3] Mechanical Design of A Quadruped Robot for Horizontal Ground to Vertical Wall Movement Abd Alsalam Sh. I. Alsalameh Shamsudin H.M. Amin Rosbi Mamat Center for Artificial Intelligence and Robotics (CAIRO) Faculty of Electrical Engineering University Technology Malaysia
- [4] R.Nagarajan and M,Saravanan, “A Carrier - Based Pulse Width Modulation Control Strategies for Cascaded Multilevel Inverter,” International Review on Modeling and Simulations (IRMOS), Vol 6.No1, pp-8-19, Feb. 2013.
- [5] A study of availability and exit usability of Theo Jansen mechanism toward climbing over bumps Kazuma Komoda (PY)1, and Hiroaki Wagatsuma 1 Department of Brain Science and Engineering, Kyushu I institute of Technology 2 RIKEN Brain Science Institute
- [6] R.Nagarajan and M, Saravanan, “Comparison of PWM Control Techniques for Cascaded Multilevel Inverter” International Review of Automatic control (IRACO), Vol.5, No.6, pp. 815-828. Nov. 2012.
- [7] G. Vidhya Krishnan, R.Nagarajan, T. Durka, M.Kalaiselvi, M.Pushpa and S. Shanmuga priya, "Vehicle Communication System Using Li-Fi Technology," International Journal of Engineering And Computer Science (IJECS), Volume 6, Issue 3, pp. 20651-20657, March 2017.
- [8] Artificial active whiskers for guiding underwater autonomous walking robots T. Rooney_, M.J.Pearson, J. Welsby, I. Horsfield, R. Sewell, S. Dogramadzi Bristol Robotics Laboratory, University of the West of England, Bristol, BS161QD, UK
- [9] M.Dharani Devi and R.Nagarajan, “Implementation of Different PWM Control Strategies for Cascaded MLI,” Journal of Network Communications and Emerging Technologies (JNCET), Volume 7, Issue 7, pp. 49- 55, July-2017.
- [10] R.Prabhu, R.Nagarajan, N.Karthick and S.Suresh, “Implementation of Direct Sequence Spread Spectrum Communication System Using FPGA,” International Journal of Advanced Engineering, Management and Science (IJAEMS), Vol-3.Issue-5, pp. 488-496, May. 2017
- [11] Soyguder S, Alli H; Design and prototype of a six legged walking. International Journal of Industrial Robot, 2007; 34(5): 412–422.
- [12] R. Banupriya, R.Nagarajan, M.Malarvizhi and M.Dharani Devi, “Multicarrier - Based PWM Control Strategies for Five - Level CMLI.” Journal of Network Communications and Emerging Technologies (JNCET), Vol. 7, Issue 11, November - 2017, pp. 33-39.
- [13] M.Dharani Devi, M.Malarvizhi and R.Nagarajan, “Development of Multicarrier SPWM Techniques for Cascaded MLI.” International Journal of Computational Engineering Research (IJCER), Vol. 7, Issue 10, October 2017, pp. 44-52.
- [14] J.Chandramohan, R.Nagarajan, K.Satheeshkumar, N.Ajithkumar, P.A.Gopinath and S.Ranjithkumar, "Intelligent Smart Home Automation and Security System Using Arduino and Wi-fi," International Journal of Engineering And Computer Science (IJECS), Volume 6, Issue 3, pp. 20694-20698, March, 2017.
- [15] Lovasz E Ch, Pop C, Pop F, Dolga F; Novel Solution for Leg Mechanism. Int. J. of Applied Mechanics and Engineering, 2014; 19(4): 699-708.
- [16] K. Anandhi and Dr. R. Nagarajan, “Mutex-Heart: Fail Safe Dual Chamber Cardiac Pacemaker Device with Rate Responsive Control and Cryptographic Security,” IJSRD- International Journal for Scientific Research & Development. Vol. 3, Issue- 2, pp. 489-493, 2015.
- [17] Inoue H, Noritsugu T; Development of Walking Assist Machine Using Linkage Mechanism.
- [18] J.Chandramohan, R.Nagarajan, M.Ashok kumar, T.Dineshkumar, G.Kannan and R.Prakash, “Attendance Monitoring System of Students Based on Biometric and GPS Tracking System,” International Journal of Advanced Engineering, Management and Science (IJAEMS), Vol-3.Issue-3, pp. 241-246, Mar. 2017.
- [19] A study of availability and extensibility of Theo Jansen mechanism toward climbing over bumps Kazuma Komoda (PY)1, and Hiroaki Wagatsuma 1 Department of Brain Science.
- [20] R Rameshkumar and R Nagarajan, “Sine Multicarrier SPWM Technique for Seven Level Cascaded Inverter,” CiiT-Programmable Device Circuits and Systems. Vol. 5, Issue- 6, 2013.
- [21] Dr.R.Nagarajan, S.Sathishkumar, K.Balasubramani, C.Boobalan, S.Naveen and N.Sridhar. “Chopper Fed Speed Control of DC Motor Using PI Controller,” IOSR- Journal of Electrical and Electronics

- Engineering (IOSR-JEEE), Volume 11, Issue 3, Ver. I, pp. 65-69, May – Jun. 2016.
- [22] R.Nagarajan and M,Saravanan “Staircase Multicarrier SPWM Technique for Nine Level Cascaded Inverter,” 2013 International Conference on Power, Energy and Control (ICPEC), IEEE Press, pp-668-675. 2013.
- [23] A study of availability and extensibility of Theo Jansen mechanism toward climbing over bumps Kazuma Komoda (PY) and Hiroaki Wagatsuma 1 Department of Brain Science.
- [24] N.Karthick, R.Nagarajan, S.Suresh and R.Prabhu, "Implementation of Railway Track Crack Detection and Protection," International Journal Of Engineering And Computer Science (IJECS), Volume 6, Issue 5, May 2017, pp. 21476-21481, DOI: 10.18535/ijeecs/v6i5.47
- [25] M.Padmavathi and R.Nagarajan, “Smart Intelligent ATM Using LABVIEW,” International Journal of Emerging Technologies in Engineering Research (IJETER), Volume 5, Issue 5, pp. 41- 45, May-2017.
- [26] R.Nagarajan and M, Saravanan. “Performance Analysis of a Novel Reduced Switch Cascaded Multilevel Inverter,” Journal of Power Electronics, Vol.14, No.1, pp. 48-60, Jan.2014.
- [27] Soyguder S, Alli H; Design and prototype of a six legged walking. International Journal of Industrial Robot, 2007; 34(5): 412–422
- [28] R.Nagarajan, S.Sathishkumar, S.Deepika, G.Keerthana, J.K.Kiruthika and R.Nandhini, "Implementation of Chopper Fed Speed Control of Separately Excited DC Motor Using PI Controller", International Journal of Engineering And Computer Science (IJECS), Volume 6, Issue 3, pp. 20629-20633, March, 2017.
- [29] Lovasz E Ch, Pop C, Pop F, Dolga F; Novel Solution for Leg Mechanism. Int. J. of Applied Mechanics and Engineering, 2014; 19(4): 699-708.
- [30] R.Nagarajan, R.Yuvaraj, V.Hemalatha, S.Logapriya, A.Mekala and S.Priyanga, "Implementation of PV - Based Boost Converter Using PI Controller with PSO Algorithm," International Journal of Engineering And Computer Science (IJECS), Volume 6, Issue 3, pp. 20479-20484, March, 2017.
- [31] Ms. C. Hemalatha, Mr. R. Nagarajan, P. Suresh, G. Ganesh Shankar and A. Vijay, “Brushless DC Motor Controlled by using Internet of Things,” IJSTE - International Journal of Science Technology & Engineering, Volume -3.Issue-09, pp. 373-377, March- 2017.
- [32] R.Nagarajan, J.Chandramohan, S.Sathishkumar, S.Anantharaj, G.Jayakumar, M.Visnukumar and R.Viswanathan, “Implementation of PI Controller for Boost Converter in PV System,” International Journal of Advanced Research in Management, Architecture, Technology and Engineering (IJARMATE). Vol.11, Issue.XII, pp. 6-10, December. 2016.
- [33] M.Elangovan, R.Yuvara, S.Sathishkumar and R.Nagarajan, “Modelling and Simulation of High Gain Hybrid Boost Converter,” International Journal of Emerging Technologies in Engineering Research (IJETER), Volume 5, Issue 6, pp. 9- 14, June-2017
- [34] R.Nagarajan, J.Chandramohan, R.Yuvaraj, S.Sathishkumar and S.Chandran, “Performance Analysis of Synchronous SEPIC Converter for a Stand-Alone PV System,” International Journal of Emerging Technologies in Engineering Research (IJETER), Vol. 5, Issue - 5, pp. 12-16, May-2017
- [35] S.Suresh, R.Nagarajan, L.Sakthivel, V.Logesh, C.Mohandass and G.Tamilselvan, “Transmission Line Fault Monitoring and Identification System by Using Internet of Things,” International Journal of Advanced Engineering Research and Science (IJAERS), Vol - 4.Issue - 4, pp. 9-14, Apr- 2017.
- [36] M. Sridhar, S.Sathishkumar, R.Nagarajan and R.Yuvaraj, “An Integrated High Gain Boost Resonant Converter for PV System,” International Journal of Emerging Technologies in Engineering Research (IJETER), Volume 5, Issue 6, pp. 54- 59, June-2017.
- [37] Inoue H, Noritsugu T; Development of Walking Assist Machine Using Linkage Mechanism. An International Journal of Robotics and Mechatronics, 2010; 22(2): 189-196
- [38] M.Meenakshi, R.Nagarajan, R. Banupriya and M.Dharani Devi, “Stepped Multicarrier SPWM Techniques for Seven - Level Cascaded Inverter,” International Journal of Emerging Technologies in Engineering Research (IJETER), Volume 5, Issue 12, pp. 43- 49, December-2017.
- [39] S.Suresh, R.Nagarajan, R.Prabhu and N.Karthick, "Energy Efficient E0 Algorithm for Wireless Transceivers," International Journal of Engineering and Computer Science (IJECS), Volume 6, Issue 7, July 2017, pp. 21982-21985, DOI: 10.18535/ijeecs/v6i7.15.