

## STUDYING THE DYNAMIC CHARACTERISTICS TO LENGTHEN THE OPERATING LIFE FOR A DIESEL ENGINE USING FREQUENCY RESPONSE FUNCTION (FRF) MEASUREMENT

Subekti

Mechanical Engineering Vibration Laboratory, Universitas Mercu Buana  
Jalan Meruya Selatan No. 1, Meruya Selatan, Kembangan, Jakarta Barat, 11650  
Email: subekti@mercubuana.ac.id

**Abstract** -- This research was conducted on Diesel engine single cylinder which aims to study the dynamic characteristics of Diesel engine type HATZ 1D 80 made in Germany. The test was performed by measuring the Frequency Response Function (FRF). In this study, the vibration response was measured at three points: point A which was situated below the engine shaft and in line with the stinger. Point A indicated the FRF point. Point B was located in the valve train component, while point C was situated above the cap of the valve train component. The range of frequencies applied was 0 - 3200 Hz, 3200 - 6400 Hz, 6400 - 9600 Hz, and 9600 - 11200 Hz. This research indicates that the natural frequencies arose because of the global vibration mode. The global vibration mode occurred at natural frequencies of 3118, 4805, 4821, 5021, 7129, 8601, and 11107 Hz. While other natural frequencies were associated with the local vibration mode because it appears only at one point of measurement.

**Keywords:** Dynamic Characteristics; Diesel engine; FRF; Stinger; Vibration mode.

Received: October 29, 2017

Revised: May 30, 2018

Accepted: June 1, 2018

### INTRODUCTION

The working principle of the engine consists of a system that assembly the thermodynamic cycle and mechanical cycle. The thermodynamic cycle is known as the diagram (P-T) whereas the diagram (P-V) is known as the mechanical cycle. To operate it, the engine can be rotated in a certain spin after receiving the force from the combustion process. When the component moves, there is an inertial force generated from the combustion process. These forces will vibrate the structure of the cylinder engine. A well-designed engine generates lower vibrations, but if the usage duration is long, the vibration amplitude will be larger, and this will affect the engine condition. The generated vibration signal will have a certain frequency spectrum and vibration feature. The vibration effect that appears on the engine is highly influential, which will ultimately shorten the operating life of the engine (Xue and Howard, 2018).

To identify the function of vibration frequency response on the engine, we did a testing by using a Diesel engine. The testing was done by using Diesel engine single cylinder (brand: German 1D81 Z; type: Hazi) with the Direct Injection system (DI). The instrument acquisition and spectrum analyzer which were used were MSA (Multichannel Spectrum Analyzer).

Some researchers have tested the frequency response function, such as Delprete et

al (2010), who performed the frequency response function test in the powertrain on a cylinder engine using two excitation style methods: Impact Hammer and Exciter. The exciter is more suitable because of its ability to identify several modes with a smaller size allowing structural modes to form as a deformation capital on a single-cylinder engine component. Kumar et al (2011) compared the characteristics of two-cylinder blocks engine and bearing. The FRF characteristic of a system is the basis for determining the sensitivity of the system and any design changes that are able to change the FRF characteristics. Jian, et al (2015) performed the test using the FRF method in the combustion chamber, which showed that the frequency domain obtained had the low-frequency content. Masahiro (2015) compared the FRF method with multibody dynamic, showing the same tendency in their bolt stiffness, either on the amplitude or phase that occurs in the steering system. FRF method is also carried out to determine the passengers' comfort levels to reduce the vibrations caused by the bus frame (Dahil et al (2016)). The FRF method was also performed to detect the degree of damage or cracking on the gears (Mohamad et al, 2016). Chen et al (2017) tested the relationship between the friction coefficient resulted from the tires and the one resulted from the steering system by using the FRF method and then did a validation on the experiment and the simulation. The performance of a vehicle attenuation is measured with the FRF

method obtained from the given excitation force and then compared with the vibration obtained from the velocity level of measurement at the same point (Saha, 2017). A mathematical modeling of the vibration response that occurs on the engine has been done by Riri Sadiana (2016).

In addition to vehicles, the FRF method has also been used to detect damage to a structure (Homaei et al (2015)) and to detect a crack on a beam (Lin, (2015)).

This research was conducted to identify the frequency in each engine component, especially on the Valve train component. The amount of vibration that occurred was measured by using a vibration signal called MSA. From the MSA, we obtained the dynamic characteristics of a Diesel engine through measurement of frequency response function (FRF) with an excitation style method called exciter. The frequency response function (FRF) is the basis of measurement to identify the dynamic characteristic in a mechanical structure. Experimental capital parameters (frequency, attenuation, and shape mode) can be obtained from FRF measurement.

**LITERATURE REVIEW**

The Frequency Response Function (FRF) is the ratio of the vibration response signals received by a mechanical structure resulted from the excitation force of a system in the frequency domain. The vibration response and the vibration excitation signals are measured simultaneously using a vibration sensor and load cell which acted as the exciter force to measure the instruments. By applying Fourier transform, we obtained the data and the result of the transformation in the frequency domain.

A system in Fig. 1 shows the systems of mass, spring, and damper. Those systems are continuously subjected to a force of  $F_o$ . The system is often referred to as a Single Degree of Freedom (SDOF). From the SDOF system, we can know the natural frequency system. The Natural Frequency is the frequency at which a structural system experiences oscillation in its mass and stiffness when received an excitation force, while when the force is removed, the structure will oscillate freely. Natural frequencies are the part of the capital property. The displacement of the structure when vibrating is called the vibration mode. The physical properties of the structure strongly influence the vibration frequency.

To find out the amplitude of the  $x$  deviation, we need to know the characteristic magnitude of  $x$  to  $\omega$ . Based on the free-body diagram of Fig. 1, the motion equation of the object is:

$$m\ddot{x} + c\dot{x} + kx = F_o \tag{1}$$

If

$$x = Xe^{i\omega t} \tag{2}$$

$$\dot{x} = i\omega Xe^{i\omega t} \tag{3}$$

$$\ddot{x} = -\omega^2 Xe^{i\omega t} \tag{4}$$

$$m\ddot{x} + c\dot{x} + kx = F_o \tag{5}$$

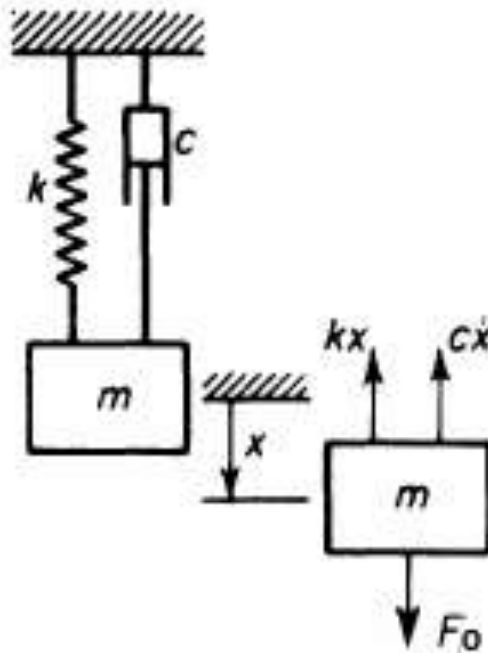

Figure 1. SDOF Vibration System Model

After substituting Equ. (2)-(5) to Equ. (1), it obtained that:

$$-m\omega^2 Xe^{i\omega t} + ci\omega Xe^{i\omega t} + kXe^{i\omega t} = Fe^{i\omega t} \tag{6}$$

$$\{(k - m\omega^2) + i(c\omega)\}Xe^{i\omega t} = Fe^{i\omega t} \tag{7}$$

$$\{(k - m\omega^2) + i(c\omega)\}X = F \tag{8}$$

$$\frac{X}{F} = \frac{1}{(k - m\omega^2) + i(c\omega)} \tag{9}$$

$$= \frac{1}{k\left[1 - \left(\frac{\omega}{\omega_n}\right)^2 + i2\zeta\left(\frac{\omega}{\omega_n}\right)\right]}$$

Based on Equ. (9), it can obtain the magnitude equation and the phase angle as follows:

$$|H(\omega)| = \frac{1}{(k - m\omega^2) + i(c\omega)} \tag{10}$$

$$= \frac{1}{k\left[\left(1 - \left(\frac{\omega}{\omega_n}\right)^2\right)^2 + \left(2\zeta\left(\frac{\omega}{\omega_n}\right)\right)^2\right]}$$

While the phase angle is

$$\varphi = \tan^{-1}\left(\frac{c\omega}{k - m\omega^2}\right) = \tan^{-1}\left(\frac{2\zeta\left(\frac{\omega}{\omega_n}\right)}{1 - \left(\frac{\omega}{\omega_n}\right)^2}\right) \tag{11}$$

The frequency response function (FRF) can be obtained by measuring the frequency spectrum of the vibration response signal received by a mechanical structure produced by the excitation force of the vibration. The frequency response function is divided into three groups based on the responses which are measured. First is displacement response which is called as receptance

$$\alpha(\omega) = \frac{x}{F} \quad (12)$$

Then, a velocity response which is called as mobility

$$Y(\omega) = \omega\alpha(\omega) \quad (13)$$

And, an acceleration response which is called as inertance

$$A(\omega) = -\omega^2\alpha(\omega) \quad (14)$$

In measuring the vibration of the engine, the data about the signal is obtained from the response signal which comes from the inside or outside of the Diesel engine. In general, to identify the signal from the vibration source, we usually do the measurement in the time domain to describe the original form of the vibration signal of the structure which is being measured. A simple signal in time domain is very easy to analyze but the complex signal is not. Therefore, we need an analysis in the frequency domain. The frequency domain is obtained by using Fast Fourier Transforms (FFT), where every periodic signal is the result of the sum of sine or cosine signals contained in different fractions.

The measurement of vibration generates noise so a coherence function is required. Coherence function shows the degree of the linear relationship between two signals as a frequency function. Coherence function consists of Cross Spectral Density and Auto Spectral Density. Mathematically, it can be written as follows

$$\gamma^2(f) = \frac{|G_{AB}(f)|^2}{G_{AA}(f) \cdot G_{BB}(f)} \quad (15)$$

where  $G_{AB}$  is the Cross Spectral Density between the input signal and output signal, while  $G_{AA}$  and  $G_{BB}$  are the Auto Spectral Density of input and output signals.

In each coherency, the frequency can be taken as the coefficient of correlation (squared) which expresses the level of linear relationship between two variables, the cross-correlation function in the frequency domain having dimensionless features and the value of 0 and 1, the number indicates whether there is an outside noise signal or Noise which is also measurable during shaving, as shown in Fig. 2.

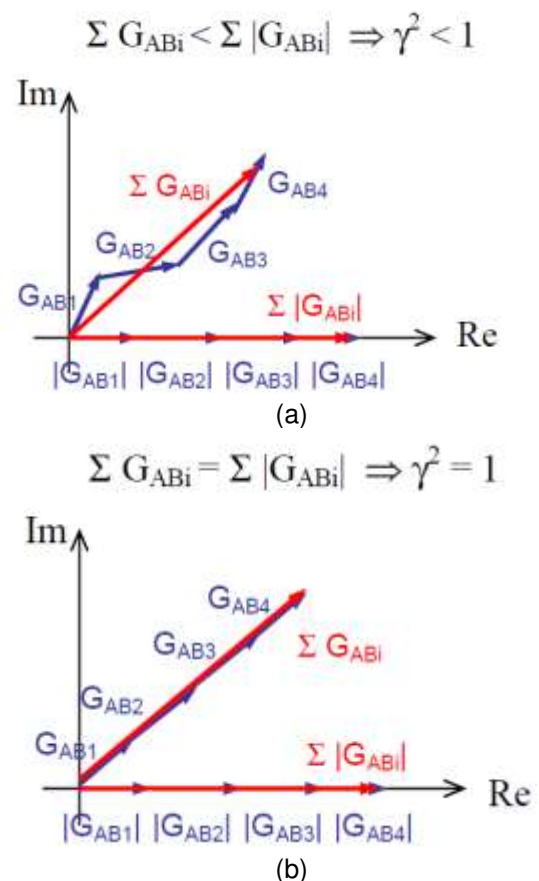

Figure 2. Effect of Noise on coherence: (a) with Noise and (b) without Noise

## METHOD

Identifying the dynamic characteristics of the Diesel engine, we performed the measurement using the Frequency Response Function (FRF). The excitation force was applied to the cylinder of the Diesel engine using vibration exciter. The excitation force was applied to the cylinder shaft of the engine in a vertical direction. The measurement of vibration response was carried out at three points: point A which is situated below the engine shaft and in line with the stinger, as shown in Fig. 3 (a). Thus, FRF at point A shows the FRF point. Point B is located in the valve train component, the point C is located above the cap of the valve train component, as shown in Fig. 3 (b) and (c).

Those measurement points were selected because there will be a further research on vibration characteristics that occur in all three areas, especially on the Valve train component, when the engine is turned on. The FRF measurement in this study used four frequencies, which are 0 - 3200 Hz, 3200 - 6400 Hz, 6400 - 9600 Hz and 9600 - 11200 Hz. Those four different frequencies were used because, when the testing of an engine is in the lit state, we can use those

frequencies. The photo which describes the setup test to get the experimental data can be seen in Fig. 4.

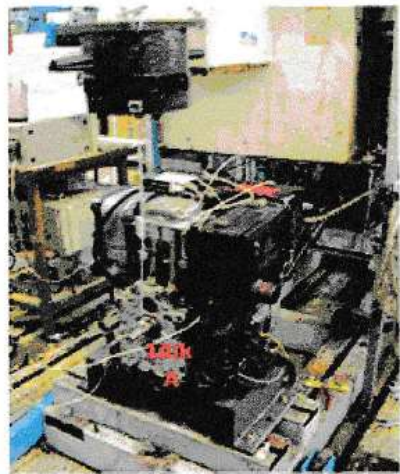

(a)

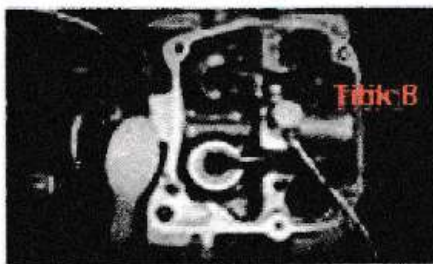

(b)



(c)

Figure 3. The Photograph measurement of frequency response function

The devices structure of the FRF measurement is shown in Fig. 4. In that figure, it can see the types of equipment that can be used, which are as follows:

- Accelerometer, in this study we used the piezoelectric accelerometer made by IMV Corporation type VP 200, VP51 and VP 11 (SUS). Accelerometer acts to measure vibration response.
- the ref sensitivity specifications of the load cells which were used were 50 Hz, 23°C, 3.93 pC / N
- Charge amplifier serves to amplify the signal coming from the Accelerometer.
- Multichannel spectrum analysis (MSA) is composed of mainframe HP35360A and PC which is equipped with software to operate the instrument with the maximum frequency range that can be analyzed is 12.8 kHz produced by Hewlett and Packard. MSA was used as a source of excitation signals, spectrum analyzers and acquisition data in this study.
- Power amplifier, the one which was used as the output capacity of 180 VA. The reduction capacity was DC-100 kHz and the operating temperature was 5 - 40°C. The power amplifier serves to strengthen the excitation signal derived from Multichannel spectrum analysis
- Vibration exciter, manufactured by Brüel & Kjær. It functions as an electrical signal converter into mechanical energy to provide vibration.

While the object which was tested in this research was the Diesel engine (brand: Hazt; type: 1D81Z) made in Germany with the direct injection system (D) shown in Fig. 5. The Diesel engine of specifications are

- Stroke (2R): 85 mm
- the Volume of the step cylinder: 667 cm<sup>3</sup>
- Conrod: 147 mm
- Bore: 100 mm
- Compression ratio: 20.5
- Maximum rotation: 3000 rpm
- Cooler: air



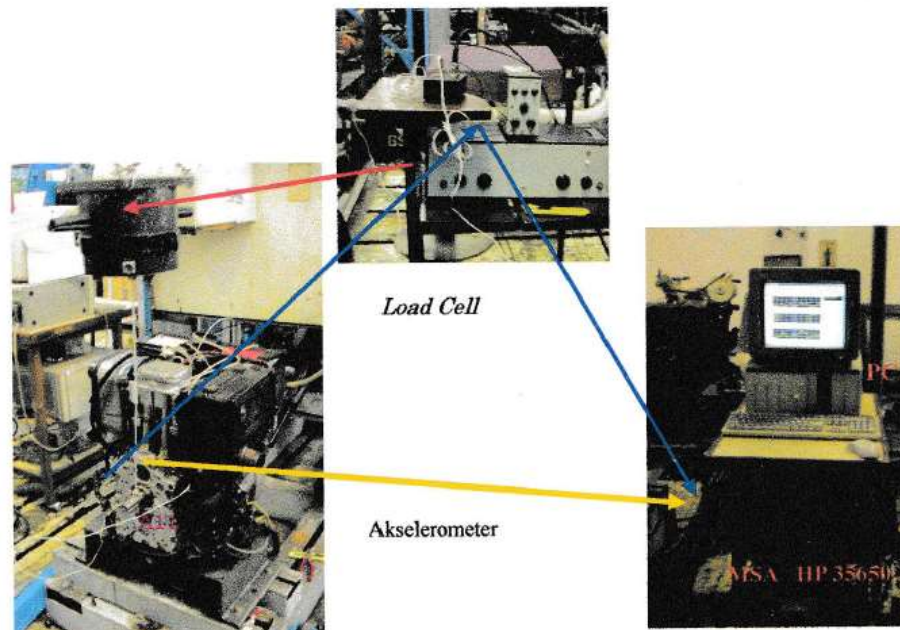

Figure 4. Photo of Set-up testing frequency response function

## RESULTS AND DISCUSSION

Fig. 6 and Fig. 7 show one of the FRF measurements. The figure shows the result of FRF measurement at point A or FRF point, for frequencies of 0 - 3200 Hz and 3200 - 6400 Hz. In the frequency of 0 - 3200 Hz, there were 3 natural frequencies which are 1779, 1927 and 3118 Hz, as shown in Fig. 6. Fig. 7 shows the results of FRF measurements. It is shown that in the frequency of 3200 - 6400 Hz there were four personal frequency: 3399, 4605, 4821 and 5943 Hz.

The coherence value that was obtained at all natural frequencies was 0.99. This shows that Noise obtained at natural frequency is very small. Thus, the confidence level of FRF measurement is very high.



Figure 5. The Diesel engine with Hazt type 1D81Z

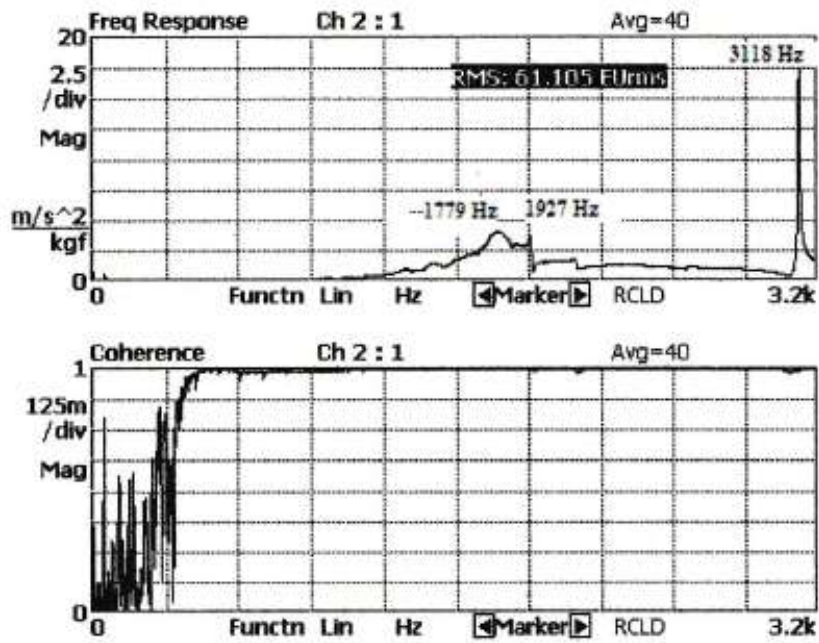

Figure 6. The Result of FRF Point measurement for frequencies range (0 - 3200 Hz)

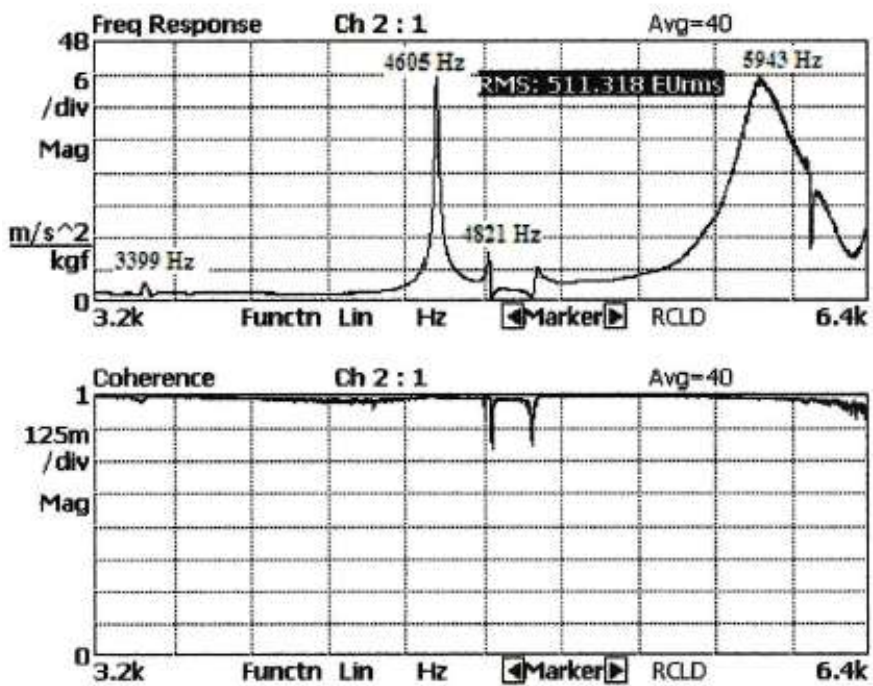

Figure 7. The result of FRF Point measurement of the frequency range from 3200 - 6400 Hz

Table 1. Natural frequency FRF measurement results

Natural Frequency	Point		
	A	B	C
1	1779	-	-
2	1926	-	-
3	3118	3119	3118
4	3399	-	3396
5	-	3415	-
6	-	-	3428
7	-	-	3536
8	4805	4805	4805
9	4821	4824	4821
10	5021	5021	-
11	5043	-	-
12	-	-	5053
13	-	-	5226
14	-	-	5754
15	-	-	5892
16	-	-	5951
17	-	5941	-
18	6582	-	6579
19	-	-	7029
20	7004	-	-
21	7129	7129	-
22	-	-	7137
23	-	-	7229
24	-	-	7938
25	-	-	8340
26	-	-	8599
27	8601	8601	-
28	8729	-	-
29	-	-	10330,5
30	10320,5	-	-
31	11107	11107	-
32	-	-	11114,5

The natural frequencies obtained from the FRF measurements in this study are presented in Table 1. This table shows the presence of natural frequencies that appear in more than one remote measurement point. This shows that the natural frequency arises because of the global vibration mode.

## CONCLUSION

The results of the dynamic characteristics test on Diesel engine s using function response shows that:

- There is a natural frequency that appears in more than one measurement point. This frequency shows the existence of a global vibration mode.
- The global vibration mode occurs at natural frequencies of 3118,4805, 4821, 5021, 7129, 8601, 11107 Hz.

Based on the FRF test, we did the measurement of vibration on the Diesel engine, especially on the valve train component when the combustion happens. A follow-up study will be conducted to determine the vibration characteristics caused by the clearance changes

effect on the valve train, as the basis of vibration monitoring.

## REFERENCES

- Chen, L., Luo, Y., Bian, M., Qin, Z., Lou, L., and Li, K. (2017). Estimation of Tire-Road Friction Coefficient Based on Frequency Domain Data Fusion. *Mechanical System and Signal Processing*. 85, 177-192.  
<http://dx.doi.org/10.1016/j.ymssp.2016.006>
- Dahil, L., Karabulut, A., and Ucan, O.N. (2016). Investigation of Vibration Damping in the Passenger Seat Construction. *International Journal of Electronics, Mechanical and Mechatronics Engineering*. 6(1), 1117 – 1122.  
<http://dx.doi.org/10.17932/IAU.IJEMME.m.214.60604.2016.5/1.1117-1122>
- Delprete, C., Galeazzi, A., and Pregno, F. (2010). Experimental Modal Analysis of an Automotive Powertrain. *Applied Mechanics and Materials*. 24-25, 71-76.  
<http://dx.doi.org/10.4028/www.scientific.net/A MM.24-25.71>
- Homaei, F., Shojaee, S., and Ghodrati, A.G. (2015). Multiple Structural Damage Detection using Measured Frequency Response Function. *Iranian Journal of Structural Engineering*. 2(1), 13-18.
- Jian, L.B., Naber, J.D., and Blough, J.R. (2015). Frequency Response Function Adaptation for Reconstruction of Combustion Signature in A 9L Diesel Engine. *Proceedings of The Institution of Mechanical Engineers Part-C Journal of Mechanical Engineering Science*. 229(17), 3071-3083.  
<http://dx.doi.org/10.1177/0954406215569256>
- Kumar, G.A., and Rao, B.D.N. (2011). Comparison Study of Two Engine Block and Bearing Cap Assemblies Using their FRF Characteristics. *Inda HyperWorks Technology Conference*. 1-2.
- Lin, R.M. (2016). Modeling, Detection, and Identification of Flexural Crack Damage in Beam Using Frequency Response Function. *Meccanica*. 51(9), 2027-2044.  
<http://dx.doi.org/10.1007/s11012-015-0350-6>
- Masahiro, A. (2015). *Vibration Transfer Part Analysis For Combine Harvester Using Multibody Dynamics For Engine Hybrid Method Combining CAE and Experiment*. Yanmar Technical Review.
- Mohamad, O.D., and Rantatalo, M. (2016). Dynamic Response And Time-Frequency Analysis For Gear Tooth Crack Detection. *Mechanical System and Signal Processing*. 66-67, 612–624.  
<http://dx.doi.org/10.1016/j.ymssp.2015.05.015>

- Sadiana, R. (2016). Analisis Respon Sistem Getaran Pada Mesin Torak. *Jurnal Teknik Mesin*. 4(2), 41 - 46.
- Saha, P. (2017). Mechanical Impedance Based Vibration Damping Test. *SAE Technical Paper*. <http://dx.doi.org/10.4271/2017-01-1879>
- Xue, S. and Howard, I. (2018). Torsional vibration signal analysis as a diagnostic tool for planetary gear fault detection. *Mechanical Systems and Signal Processing*. 100, 706-728. <https://doi.org/10.1016/j.ymssp.2017.07.038>