

Four points bend fixture bone plate

Alaa A. Jebur

Abstract— This study is focusing on studying the bending strength of Metallic Bone Plates. This test, defines as the test methods for single cycle bend testing and for determining the bending fatigue properties of metallic bone plates. The bone plate is positioned on a 4 point bend fixture. The bend fixture should use cylindrical rollers with diameters between 6-12 mm. The recommended test configuration locates the loading rollers at one third points. The spacing of the rollers, however, is dependent on the location of the screw holes in the bone plate. This bend test is used to determine values for the mechanical need to undergo several tests before gaining approval as internal fixation devices of the skeletal system. One of response of bone plates to a specific type of bending load. The information resulting from this test method can give the surgeon some insight into the mechanical response of a given bone plate.

Index Terms—Metallic bone plate, four point bend fixture, internal fixation.

I. INTRODUCTION

This test method is used to determine the fatigue life at a specific or over a range of bending moment levels. It may also be used to estimate the fatigue strength for a specific number of cycles. The bone plate is positioned in a 4 point bend fixture so that a bone plate's section that would normally bridge the fracture site is subjected to a uniform bending moment as shown in (Fig.1). [1].



Fig.1 schematic representation[2].

II. MATERIALS AND METHODS

A. Apparatus (Definitions and dimensions):

Bone plate—a metallic device with three or more holes or slot(s), or both, and a cross section that consists of at least two dimensions (width and thickness) which generally are not the same in magnitude. The device is intended to provide alignment and fixation of two or more bone sections, primarily by spanning the fracture or defect. The device is

typically fixed to the bone through the use of bone screws. Where:-bone plate length, L (mm)—the linear dimension of the bone plate measured along the longitudinal axis as illustrated in (Fig. 2).

-bone plate thickness, b (mm)—the linear dimension of the bone plate measured parallel to the screw hole axis as shown in (Fig.2). For a bone plate with a crescent section, the thickness is measured at the thickest point along the section.
-bone plate width, w (mm)—the linear dimension of the bone plate measured perpendicular to both the length and thickness axes as shown in (Fig.2)[3].

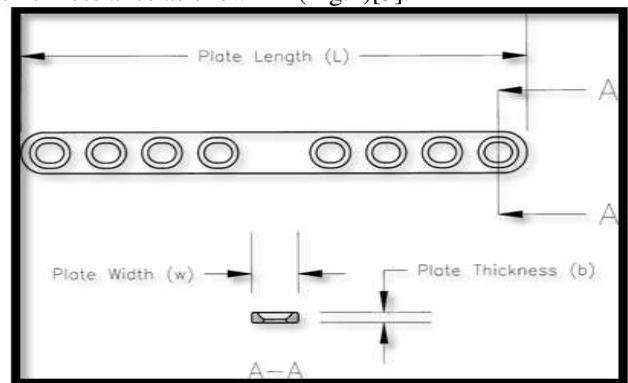

Figure 2 Bone plate dimensions [3]

The plate used in this test is a stainless steel plate with 135mm length and 8 screw's holes as shown in (Fig3).



Figure 3 The plate used in testing

The typical test confirmation is illustrated in (Fig.4)

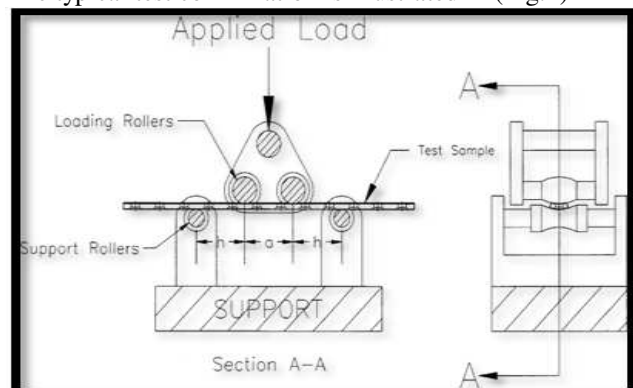

Figure 4 Test configuration [3]

Manuscript received May 20, 2014

Alaa A. Jebur, Medical engineering Department, Al Nahrain University / College of engineering., Baghdad, Iraq,

Four points bend fixture bone plate

Where:

- Center span, a (mm) the distance between two loading roller.

-Fracture load, F_{max} (N)—the applied load at the time when the bone plate fractures.

-Loading span, h (mm)—the distance between the loading roller and the nearest support.

-All loads shall be applied through rollers of equal diameters within the range of 12 mm. The selected roller diameter should not be greater than the distance between two adjacent screw holes in the bone plate to be tested. The support rollers and loading rollers were designed with four point bending load as shown in (Fig.5).

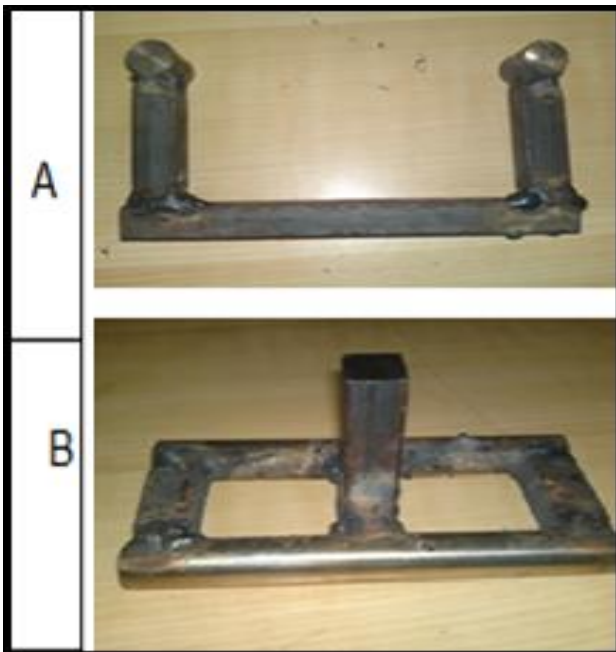

A) Support rollers
B) loading rollers

Figure 5 the support and applied rollers

B-The loading rollers and support rollers:

-The loading rollers shall be positioned so that two screw holes will be located between the loading rollers, the center span distance was recorded as a (41mm). The support rollers shall be located equal distances away from the adjacent loading roller so that two screw holes will be located between the adjacent loading and support rollers. The distance between the loading roller and nearest support roller was recorded as the loading span h is (32 mm). -The recommended testing configuration locates the loading rollers at approximately the one-third points between the supporting rollers.

-The applied load shall be shared equally by both loading rollers.

-Cylindrical rollers shall be used to test flat bone plates and bone plates of curved cross-section, in which the deviation from flatness at the center of the bone plate does not exceed $w/6$ as shown in (Fig.6) .

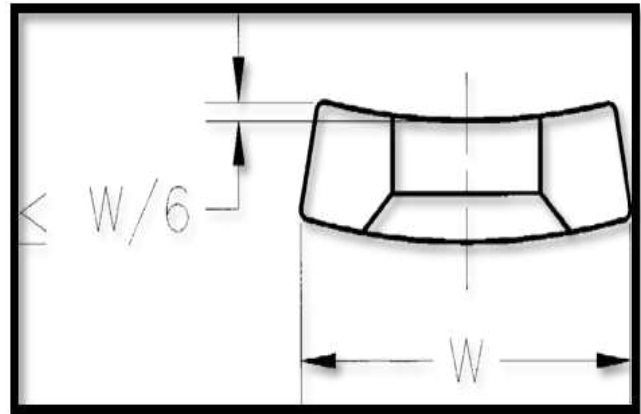

Figure 6 Roller profiling requirements [3]

III. THE TYPICAL TEST PROCEDURE:

The bone plate was placed in the testing fixture and positioned it in accordance with the following:

- The bone plate was placed so that the loading rollers are in contact with the surface of the bone plate intended to be in contact with the bone.

-Because of the bone plate is symmetrical, it was placed symmetrically with the two innermost screw holes between the loading rollers, and the loading rollers must not be in contact with parts of the bone plate where there is a screw hole.

-The long axis of the bone plate was aligned, so that it is perpendicular to the axes of the rollers.

-The loading rollers were fixed in the bending device and the plate was fixed over the support rollers as shown in (Fig.7).

-Loads of increasing magnitude was applied, and a load versus load-point displacement diagram was generated from numeric data acquired during the test.



Figure.7 bending device

IV. THE RESULTS AND CALCULATIONS:

-After doing the bending test the values of the force and extension were recorded from the force and displacement gauges that are shown in (Fig.8) and the results were tabulated as shown in table-2.

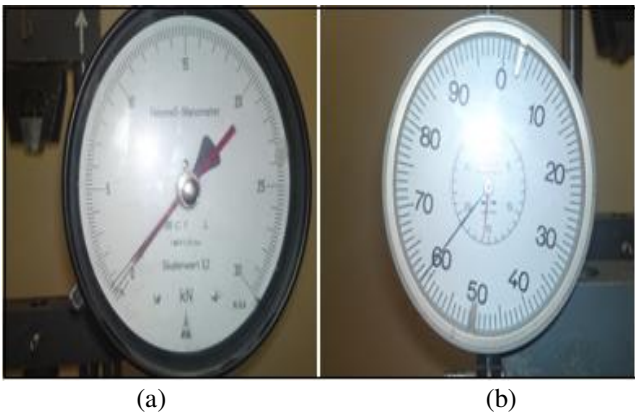

Figure 8 a- The force gauge and gauges b-the displacement gauges

Table -2 Tabulated results for bending test of the plate

Force(KN)	Displacement(mm)
0	0
2	1
3	2
3.2	3
3.5	4
3.8	5
4	6
4	7
4.2	8
4.4	9
4.7	10
4.9	11

-The load versus load-point displacement diagram was generated from numeric data acquired during the test as shown in (Fig.9).

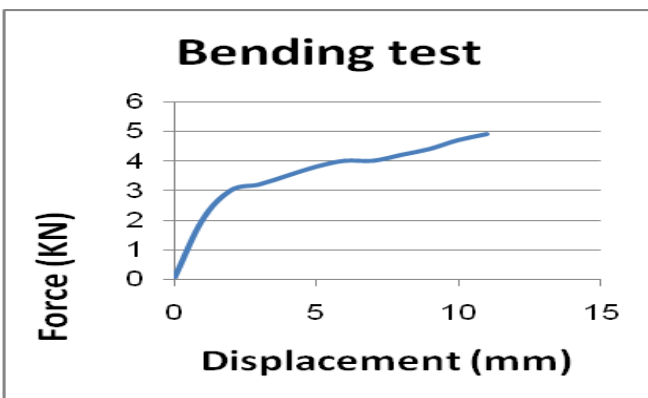

Figure .9 Diagram of bending test

- The 0.2 % offset displacement, q, used to determine the bending strength

$$q = 0.002 * a$$

$$q = 0.002 * 41$$

$$q = 0.082 \text{ mm}$$

-The proof load was calculated from this curve as shown in (Fig .10) .

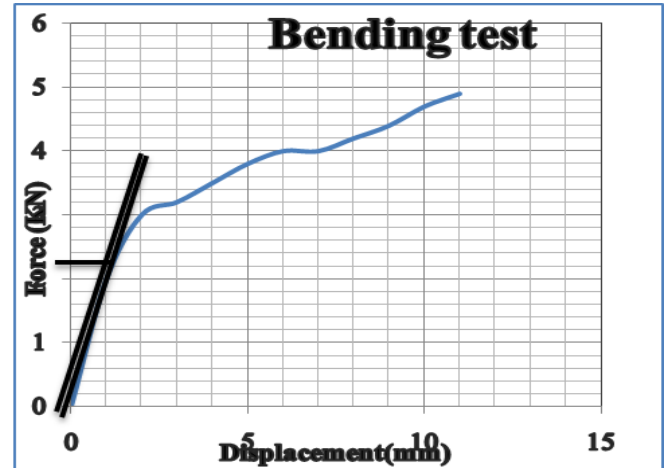

Figure .10 Diagram illustrating methods for determining bending properties of bone plates.

Proof load (P)=2.4 KN

$$\text{Bending strength} = (Ph)^2$$

$$= (2.4 * 32)^2$$

$$= 38.4 \text{ N.m}$$

In the final of bending test the bending plate shown in (Fig.11).

And it is compared with plate that is bending inside the patient due to body stress as shown in (Fig.12).



Figure 11The bending plate by mechanical test.



Figure 12 The implanted plate in patient after removal

A-Simply supported beam :

For calculated the shearing force and bending moment from the four point of support and load rollers shown in fig.3.12.

$$\sum MD = 0$$

$$0 = 4.9 \times 32 + 4.9 \times 73 - A(105\text{mm})$$

$$A = 4.9 \text{ KN}$$

$$\sum FY = 0$$

$$0 = 4.9 - 4.9 - 4.9 + D$$

$$D = 4.9 \text{ KN}$$

Shearing Force (S.F):

$$A = 4.9$$

$$B = 4.9$$

$$C = 4.9 - 4.9 = 0$$

$$D = -4.9$$

Bending Moment (B.M):

$$A = 0$$

$$B = 4.9 \times 32 = 156.8$$

$$C = 4.9 \times 73 - 4.9 \times 32 = 200.9$$

$$D = 0$$

V. DISCUSSION

This bend test is used to determine values for the mechanical response of bone plates to a specific type of bending load. The information resulting from this test method can give the surgeon some insight into the mechanical response of a given bone plate.

A critical characteristic of bone plates for orthopedic applications is the bending properties since the bone plate provides the primary means of stabilizing the bone fragments. Additionally, the bending stiffness of the bone plate may directly affect the rate and ability of healing.

The bending strength that was found for the stainless steel plate can give the surgeon some insight into the mechanical response of a given bone plate.

Since the loading on the bone plate in situ will, in general differ from the loading configuration used in this method, the results obtained from this test method cannot be used directly to predict in vivo performance of the bone plate being tested. Such mechanical property data can be used to conduct relative comparisons of different bone plates designs.

Stress fracture in implant (fatigue) fracture is one occurring in the normal bone of a healthy patient. It is caused, not by specific traumatic incident, but frequently repeated forces, which are of two main kinds: Bending and compression.

Bending force: which breach one cortex; healing begins, but with repeated stress and breach may extend across the bone. This variety affects young adults and is probably due to muscular action, which tends to deform bone.

Compression force: which act on soft cancellous bone; with frequent repetition an impacted fracture may follow [4].

- [1] ASTM F382-99 Metallic Bone Plate Plate -4 point Bend Test
- [2] Trustee company for analysis, evaluation, investigation and examination of materials, Bending Fatigue Test of Bone Plates, 2014
- [3] Standard Specification and Test Method for Metallic Bone Plates1, Current edition approved Apr. 10, 2003. Published May 2003. Originally approved in 1973. Last previous edition approved in 1999 as F 382 – 99.
- [4] APLEY A., Grahman, and Solomon Louis: Apley's system of orthopaedics and fractures. Seventh Ed., London Boston Durban Singapore Sydney Toronto Wellington. 1993. P.515-537.