

Performance Analysis of MS Patch Antenna with EBG structure

Bharti Agarwal, Sunil Sharma

Abstract— A Microstrip patch antenna design is characterized and optimized using HFSS antenna simulation software. In this thesis we will see the effects of EBG structures with Microstrip patch antenna. Microstrip patch antennas became very popular because of ease of analysis and fabrication, and their attractive radiation characteristics. But also, they have some drawbacks of low efficiency, narrow bandwidth and surface wave losses. We will discuss only about surface waves and its losses.

In order to overcome this limitation, EBG (Electromagnetic Band gap) Structures are inserted in the Microstrip Patch Antenna and due to this MS Antenna performance is improved. These periodic structures have the unique property of preventing the propagation of electromagnetic waves for specific frequencies and directions. The aim of this project is to design and simulate the new EBG structures operating at 2.4GHz resonant frequency and study the performance of the rectangular Microstrip patch antenna with and without EBG structure.

The substrate material is changed from RT Duroid (material in nominal HFSS design) to FR4 due to lower cost and availability. The operating frequency is changed from 2.3GHz (specified in nominal HFSS design) to 2.4GHz for wireless communication applications. Required dimensional adjustments when changing substrate materials and operating frequencies for this antenna are non-trivial and the new design procedure is used to tune the antenna. The experimental results are compared to theoretical predictions. The results show that the new design procedure can be successfully applied to Microstrip patch antenna design.

Index Terms—About four key words or phrases in alphabetical order, separated by commas.

I. INTRODUCTION

Microstrip antenna is most common small sized antenna in which a metal patch is deposited on dielectric material. Microstrip patch antennas have been an attractive choice in mobile and radio wireless communication. This is because they have advantages such as low profile, conformal, low cost and robust. However, at the same time they have disadvantages of low efficiency, narrow bandwidth and surface wave losses. Recently, there has been considerable research effort in the electromagnetic band gap (EBG) structure for antenna application to suppress the surface wave and improve the radiation performance of the antenna.

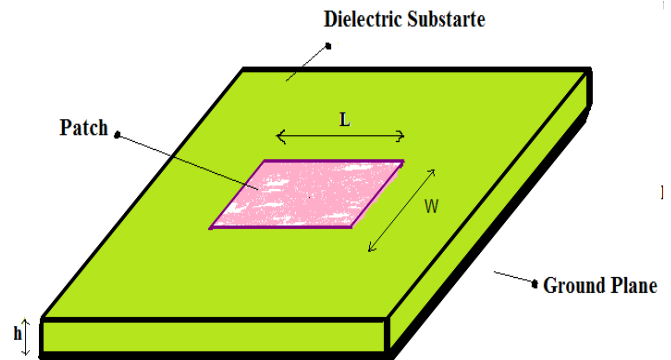

Figure- 1.1 Geometry of Microstrip Patch Antenna

II. ANALYSIS METHODS

Microstrip patch antennas are analyzed by different methods:

1. **Transmission line Model:** The transmission line model is the simplest of all and it gives good physical insight but it is less accurate.
2. **Cavity model:** The cavity model is more accurate and gives good physical insight but is complex in nature.

Full Wave Model: The full wave models are extremely accurate, versatile and can treat single elements, finite and infinite arrays, stacked elements, arbitrary shaped elements and coupling. These give less insight as

III. PROPOSED METHOD

I used only transmission line model to propose this work. This model represents the microstrip antenna by two slots of width W and height h separated by a transmission line of length L . The microstrip is essentially a non-homogeneous line of two dielectrics, typically the substrate and air.

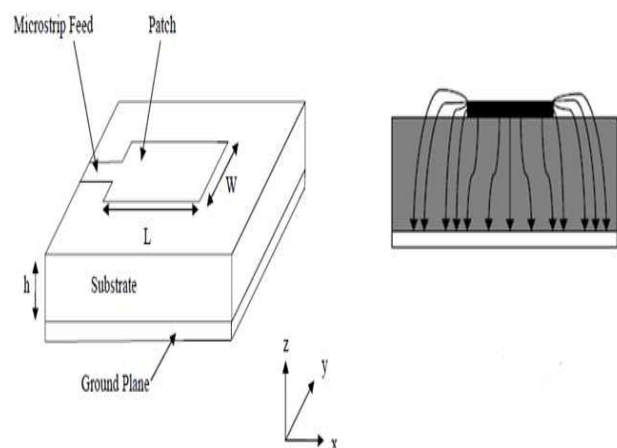

Figure-1.2 (a) Microstrip Patch Antenna
Figure-1.2 (b) Electric Field Lines

An effective dielectric constant (ϵ_{reff}) must be obtained in order to account for the fringing and the wave propagation in the line. The value of ϵ_{reff} is slightly less than ϵ_r because the fringing fields around the periphery of the patch are not confined in the dielectric substrate but are also spread in the air as shown in Figure 2.3 above.

Where

- ϵ_{reff} = Effective dielectric constant
- ϵ_r = Dielectric constant of substrate
- h = Height of dielectric substrate
- W = Width of the patch

IV. PROCEDURE OF DESIGNING MS ANTENNA

The procedure for designing a rectangular microstrip patch antenna is explained in following steps:

Step 1: Calculation of the Width (W):

The width of the Microstrip patch antenna is given as:

$$W = \frac{c}{2f_0 \sqrt{\frac{\epsilon_r + 1}{2}}}$$

Substituting $c = 3.00 \times 10^8$ m/s, (3×10^8 m/sec)

$\epsilon_r = 4.4$ and $f_0 = 2.4$ GHz, we get:

$$W = 0.038036 \text{ m} = 38 \text{ mm}$$

Step 2: Calculation of Effective dielectric constant (ϵ_{reff}):

The effective dielectric constant is:

$$\epsilon_{reff} = \frac{\epsilon_r + 1}{2} + \frac{\epsilon_r - 1}{2} \left[1 + 12 \frac{h}{W} \right]^{-\frac{1}{2}}$$

Substituting $\epsilon_r = 4.4$, $W = 38$ mm and $h = 4.8$ mm we get:

$$\epsilon_{reff} = 3.7716$$

Step 3: Calculation of the Effective length (L_{eff}):

The effective length is:

$$L_{eff} = \frac{c}{2f_0 \sqrt{\epsilon_{reff}}}$$

Substituting

$$\epsilon_{reff} = 3.7716,$$

$$c = 3.00 \times 10^8 \text{ m/s}$$

$$f_0 = 2.4 \text{ GHz we get:}$$

$$\text{and } L_{eff} = 0.03218 \text{ m} = 32.18 \text{ mm}$$

Step 4: Calculation of the length extension (ΔL):

The length extension is:

$$\Delta L = 0.412h \frac{(\epsilon_{reff} + 0.3) \left(\frac{W}{h} + 0.264 \right)}{(\epsilon_{reff} - 0.258) \left(\frac{W}{h} + 0.8 \right)}$$

Substituting $\epsilon_{reff} = 3.7716$, $W = 38$ mm and $h = 4.8$ mm we get:

$$\Delta L = 2.1520 \text{ mm}$$

Step 5: Calculation of actual length of patch (L):

The actual length is obtained by:

$$L = L_{eff} - 2\Delta L$$

Substituting $L_{eff} = 22.6043$ mm and $\Delta L = 2.5310$ mm we get:

$$L = 27.87 \text{ mm} = 28 \text{ mm}$$

V. PROPOSED DESIGN

EBG Structures are made with MS antenna by drilling the air cavities in cylindrical form and drilled only in dielectric 2 because dielectric 1 and dielectric 3 are supportive layers for antenna metals as shown in figure 1.3. Proposed model contain same parameters as in Model-N6 except air cavities(cylinders) are formed in dielectric 2 which is middle layer. **4 air cavities** are formed in this model and the radius of cylinders are $r = 4$ mm.

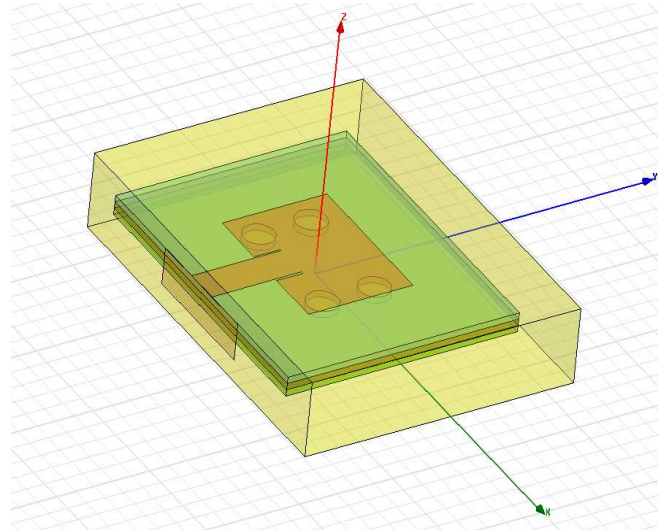

Figure- 1.3 MS Antenna with EBG Structure (4 air cavities of radius r = 4 mm)

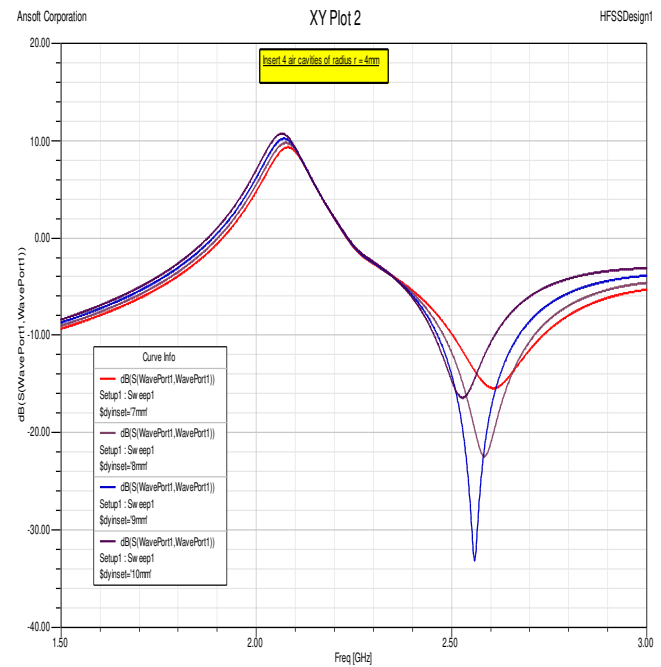

Figure: 1.4 Rectangular Plot of proposed antenna

From the above curves we see that the insertion loss is -33dB at the frequency 2.55GHz for inset 9mm. The VSWR is good for 10mm inset (dark purple color). And for 9mm inset VSWR is closer to +1. But we consider the curve of 9mm inset because at 10mm inset the insertion loss is very high(-17db) rather than 9mm(-33db).

VI. RESULTS TABLE

Item No	Item	Material (ϵ_r)	Coordinates(mm)			Dimensions(mm)		
			X_o	Y_o	Z_o	X_i	Y_i	Z_i
1	Ground Plane	Metal	-38	-31	0	76	62	Z
2	Dielectric 1	FR_4 Epoxy	-38	-31	0	76	62	1.6
3	Dielectric 2	FR_4 Epoxy	-38	-31	1.6	76	62	1.6
4	Dielectric 3	FR_4 Epoxy	-38	-31	3.2	76	62	1.6
5	Patch	Metal	-19	-14	4.8	38	28	Z
6	Feed Line	Metal	-4.5	-31	4.8	9	\$dyfeed	Z
7	Inset	-	-5	-14	4.8	10	\$dyinset	Z
8	Waveport	-	-16	-31	0	32	Y	9
9	Airbox	Air	-48	-31	-9.4	96	72	18.8
10	Cylinder 1	Air	-14	-7	1.6	r = 4	h = 1.6	Z
11	Cylinder 2	Air	-14	7	1.6	r = 4	h = 1.6	Z
12	Cylinder 3	Air	14	-7	1.6	r = 4	h = 1.6	Z
13	Cylinder 4	Air	14	7	1.6	r = 4	h = 1.6	Z

Table 1.

Antenna Name : Microstrip Patch Antenna
Frequency : 2.4 GHz

Now we will see the effects on insertion losses, when the dimension of the air cavities are changed and drilled 6 air cavities rather than 4 air cavities of same radius $r = 4\text{mm}$.

VII. CONCLUSION

The proposed antenna in which minimum insertion losses are achieved and VSWR is also good for this model as it passes through +1 value at 9 mm inset and get the higher operating frequency 2.55 GHz, which is fruitful for high frequency applications. To increase the radiation we created structure named "Electromagnetic Band Gap (EBG) structure". EBG structures are periodic arrangement of objects that prevent the propagation of EM waves in a specified band of frequency for all incident angles. The band gap features of EBG structures found useful applications in suppressing the surface waves in microstrip antenna designs