

Meander Line EBG Based Multiband Antenna for WLAN and WiMAX application

Ravindra Kumar Sharma, Mukesh Arora

Abstract— There have been many investigations in the past regarding the design of multi-band antennas. A multiband antenna is the one in which the same antenna can be operated at different frequencies. There have been many approaches towards the design of the multiband antenna like stacked patches, parasitic patches, use of slots, shaping i.e., the use of notches, reactive loading, slot loaded patches etc. The use of slots is an easier approach towards the design of multiband antenna as there is a well defined theoretical approach towards the design of the slot antennas. These slots can be cut either in the patch or in the ground plane as needed for the application. Higher gain is an important requirement for an antenna and use of Electromagnetic Band-Gap structures(EBG) is one of the promising technique to achieve this.

The present thesis work focuses on the design of multiband antenna as well as novel Electromagnetic Band-Gap structures and their integration for enhancement of the gain of the antenna at desired frequencies of operation. The multi-band antenna is designed by cutting slots in the ground plane and the Uniplanar EBG is employed for the gain enhancement.

The Fractalized Meander Line EBG based Microstrip Patch Slot Antenna operates in the 6-7 GHz (Extended C-Band) and has a fractional bandwidth of 13% , and it maintains the radiation characteristics in the desired band with gain ranging from 5.5 to 7 dB. The Meander Line EBG based Multiband Antenna operates in the WLAN and WiMAX bands at frequencies 2.4, 3.6, 5.2 GHz respectively having gain 3.5 , 4.2 and 6.19 dB

Index Terms— WLAN, WiMAX, EBG, Multiband Antenna, MPA, RFID

I. INTRODUCTION

1.1 Microstrip Patch Antennas (MPA)

The Microstrip Patch Antenna(MPA) basically consists of a dielectric substrate sandwiched between two metallic plates on both the sides. These metallic plates consist of the radiating patch on one side (top) and the ground plane on the other side. The schematic diagram of the MPA is indicated in fig. 1.1 [2],[32].

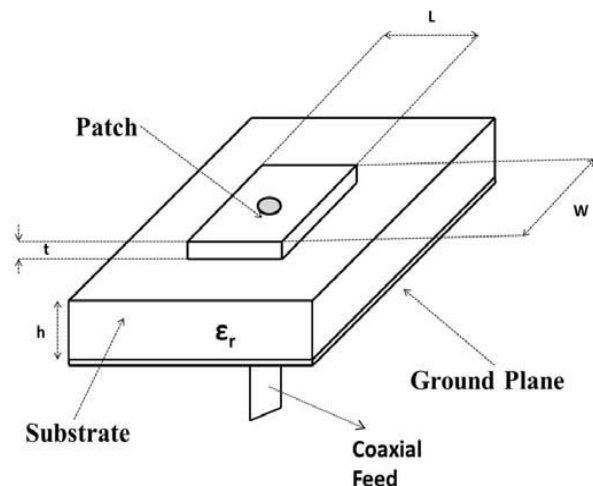

Figure 1.1: Microstrip Patch Antenna

The Patch as well as the ground plane is usually made up of conducting material like copper. The patch element as well as feed line is usually made over the substrate by removing undesirable copper cladding. The patch can be made of any shape, but for the ease of analysis usually the patch is made square, rectangular, circular, triangular, and elliptical or any other known geometrical shapes. The parameters of the MPA are L, W, h, t. Generally L lies in the range $0.333\lambda_0 < L < 0.5\lambda_0$, where λ_0 denotes the free space wavelength. The metallic patch is chosen to be very thin such that $t \ll \lambda_0$, where t denotes the thickness of the metallic patch. The height of the dielectric substrate h lies in the range $0.003\lambda_0 < h < 0.05\lambda_0$. Usually the relative electrical permittivity of the substrate generally has a value lying between $2.2 < \epsilon_r < 12$.

The MPA can be fed by many techniques like microstrip line feed, coaxial feed, aperture coupling, proximity coupling. There are many techniques available for the analysis of the MPA like Transmission line model, Cavity model where the mathematical modeling of the first method is discussed in the next section.

Microstrip antennas are used as integrated antennas in wireless devices such as mobile phones, and also employed in Satellite communications. The Microstrip Patch Antenna (MPA) finds immense applications [17] in mobile and satellite communication, Global Positioning System, Radio Frequency Identification(RFID), WiMax, RADAR, Rectenna, telemedicine applications, etc. The advantages of MPA are low weight, low profile, both linear and circular polarization, easy feeding. The main disadvantage of MPA is its low bandwidth [17]

Ravindra Kumar Sharma, Director, Radiance Public School, Shahpura, Jaipur

Mukesh Arora, Assistant Professor, Department of ECE, BIET Sikar, Rajasthan, India

1.2 Electromagnetic Band Gap (EBG) structures

Electromagnetic Band Gap structures are defined as artificial periodic (or some- times non-periodic) objects that inhibits the propagation of electromagnetic surface waves in a specified band of frequency for all incident angles and all polarization states [3].

EBG structures are simply the specific arrangement of the dielectric substrates and the metallic conductors arranged periodically in a peculiar fashion. They can be realized as 3D Volumetric structures, 2D planar surfaces, and 1D transmission lines [23]. The types of the EBG based on the above classification along with the examples are given by table 1.2.

Table 1.2: Types of EBG structures

Type	Examples
3D volumetric structures	woodpile structure and multi-layer metallic tripod array
2D planar surfaces	a mushroom-like surface and uni-planar design
1D transmission lines	microstrip line with periodic holes on the ground plane

The 2D structures are the mushroom structures and the uniplanar EBG structures. The diagram of the two structures is given in fig. 1.2.

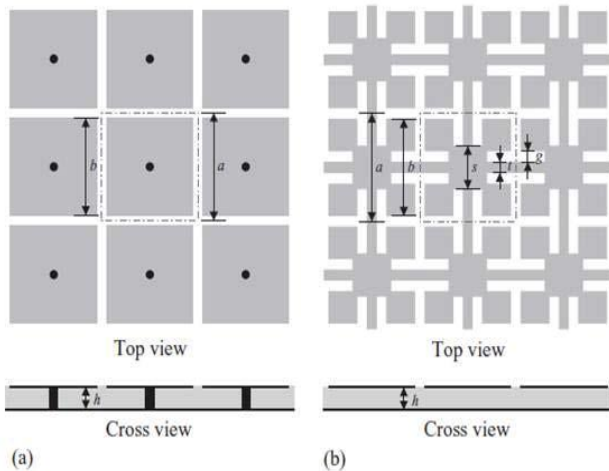

Figure 1.2: 2D EBG structures: (a) Mushroom structure (b) Uniplanar EBG

Structure

The mushroom structure consists of metallic patches and the vias connecting the ground plane and the metallic patches. Whereas the uniplanar EBG consists of the metallic patches only and the structure doesn't includes connecting vias. The entire EBG structure is placed in the same plane as the antenna hence the name Uniplanar EBG.

The Mushroom structures operate in the lower frequency range whereas the Uni- planar EBG operates in the higher frequency range (for the same unit cell size). The lower frequency operation stems from the fact that the Mushroom EBG has vias which acts as inductances, thus lowering down the frequency range. But the fabrication complexity

of the Uniplanar EBG is much higher. The Uniplanar EBG on the other side is much easier to design and fabricate.

Since the Uniplanar EBG operates at a higher frequency range, we must work out on the methods to modify the basic design as in fig. 1.2, in order to operate the EBG in the lower frequency range.

The two known principles for lowering down the operating frequencies of the Uniplanar EBG's are [6]:-

- In order to achieve compactness of the Uniplanar EBG structure, the equiv- alent capacitance and inductance has to be increased somehow in the basic Uniplanar design.
- To widen the bandwidth of the Uniplanar EBG BandGap, the value of the inductance is to be increased. 13 ~~Fractalized~~ Meander Line Uniplanar EBG

The Uniplanar EBG is designed on FR-4 (Flame Retardant-4) substrate having dielectric constant $\epsilon_r = 4.3$ and electrical conductivity (loss tangent) $\tan\delta = 0.025$ and thermal conductivity = 0.3 W/k/m. The unit cell of the designed EBG structure is depicted in fig. 3.1. The unit cell of the EBG structure differs from the basic Uniplanar EBG, where in the entire EBG structure is fractalized having first iteration only. Also the connecting lines are replaced by the meandered lines. The Unit cell size is 15mm (which is also called its periodicity). The parameters used in the design are tabulated in the table 1.3.

An array of size 5 x 5 elements is used to simulate the EBG structure as depicted in fig. 3.2. The height of the FR-4 substrate is taken as $h = 1.5\text{mm}$. On the other side of the EBG array, the ground plane is used. The discrete port is used for exciting the EBG structure, which are placed diagonally in the design. The advantage of placing the discrete port diagonally is that such an arrangement is ensuring the calculation of maximum surface wave suppression. The copper cladding of 0.018mm is considered in the design.

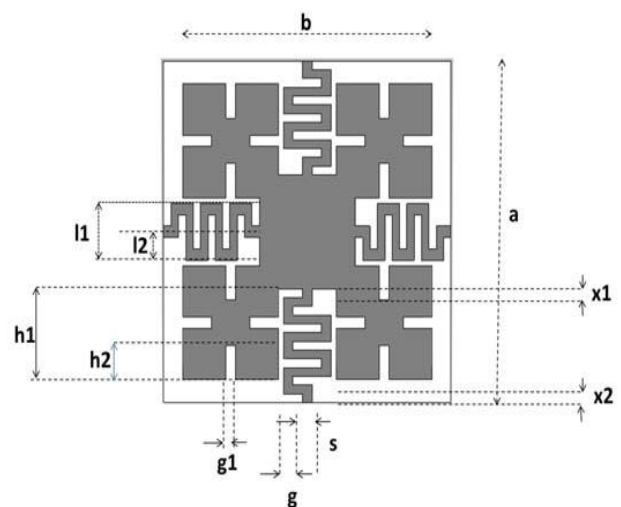

Figure 1.3: Unit Cell: EBG design 1

Parameter	Value(mm)
a	15
b	13
l1	1.5
l2	2.5
x1	0.384
x2	0.392
g	1
g1	0.5
h1	4
h2	3
s	1

The fractalized EBG structure is employed, which introduces the additional capacitances in the EBG structure thereby lowering down the frequency of operation and hence the same unit cell can have Band Gap in the lower frequency range. By introducing the meanders shape to the line, increases the value of the inductances associated with the line. This increased inductances also lead to the lowering down of the BandGap of the EBG structure.

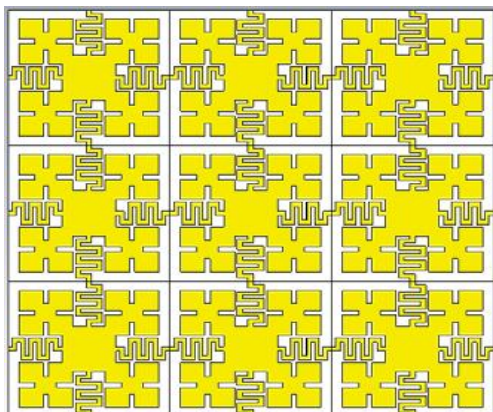

Figure 1.3.1: EBG Array

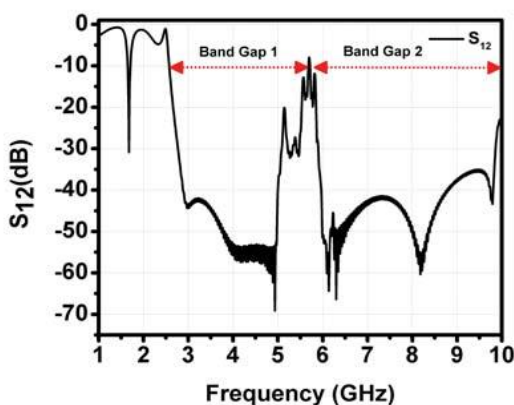

Figure 1.3.2: EBG Band Gap diagram

1.4 Meandered Line Uniplanar EBG

The EBG is made on Rogers RT 5800 substrate with dielectric constant $\epsilon_r = 2.2$ having loss tangent, i.e. electrical conductivity $\tan \delta$ as 0.0009 and the thermal conductivity as 0.2 W/k/m. The unit cell of the designed EBG structure is depicted in fig. 3.6. The Unit cell size

is 7mm (which is also called its periodicity). The unit cell designed is based on meandering principle that the meandering can help to operate the antenna or EBG structures in the lower frequency ranges. The unit cell consists of 4 meandered lines spreading out in 4 directions connected together in the center. The parameters of the design are adjusted so that the EBG operates in the desired range. The parameter values are selected by parameter variation technique

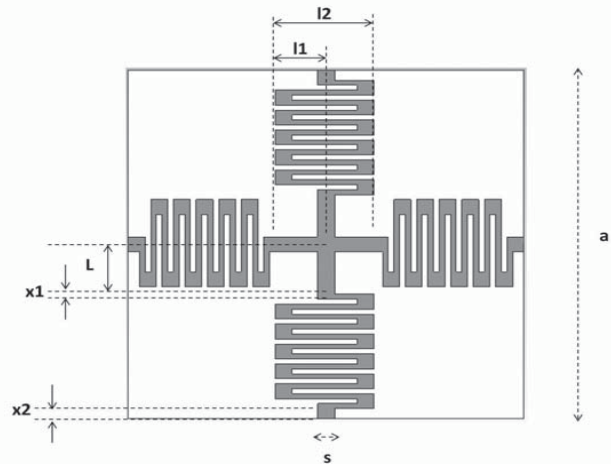

Figure 1.4: Unit Cell: EBG design 2

The parameters used in the design are tabulated as in table 1.4.

Table 1.4: List of parameters for EBG design 2

Parameter	Value(mm)
a	7
l1	1
l2	1.75
x1	0.384
x2	0.392
L	1
s	0.3

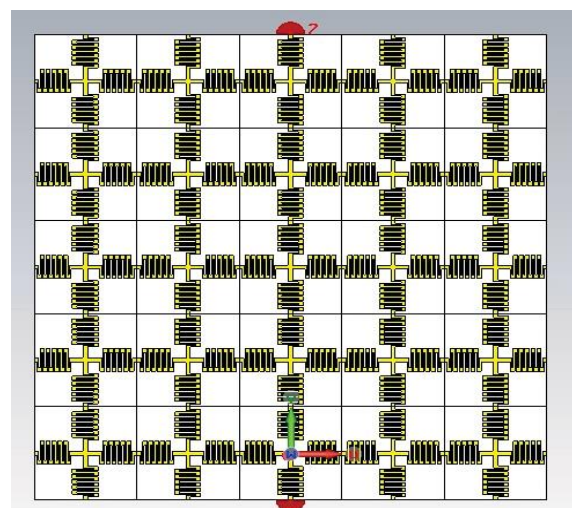

Figure 1.4.1: EBG Array: EBG design 2

An array of size 3 x 3 elements is used to simulate the EBG structure as depicted in fig. 1.4.1. The height of the FR-4 substrate is taken as $h = 1.575\text{mm}$. On the other side of the EBG array, the ground plane is used. The discrete port is used for exciting the EBG structure which is placed linearly in the structure. The copper cladding of 0.018mm is considered in the design.

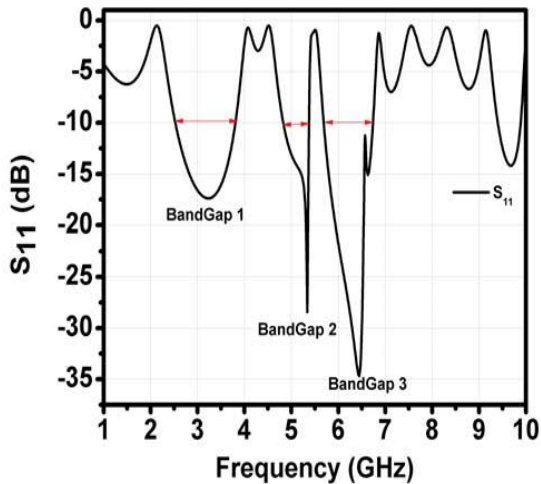

Figure 1.4.2: EBG Band Gap diagram

Figure 1.4.2 shows the 812 parameters obtained from simulation. As clearly indicated from the fig. 3.3, the EBG structure array has three distinct BandGap existing from 2.53 GHz to 3.80 GHz, the second Band Gap exists from 4.87 GHz to 5.39 GHz, whereas the third band exists from 5.68 GHz to 6.75 GHz. The characteristics of the Bandgap are tabulated in the table 1.4.1

Table 1.4.1: EBG design 2 BandGaps

BandGap	Range {GHz}	Maximum suppression {dB}
1	2.53 to 3.80	20
2	4.87 to 5.39	30
3	5.68 to 6.75	35

2.1 Meander Line EBG Based Multiband Antenna for WLAN and WiMAX applications

2.1.1 Description of the Antenna combined with the EBG

The fig. 2.1 shows the multiband antenna with EBG structure embedded into it. In fig. 2.1, (a) depicts Top view of the antenna where the microstrip line is surrounded by Meander line EBG in order to suppress the surface waves, reduces losses incurred due to the surface wave propagation, and in turn enhances gain in the respective bands. Similarly, (b) shows the bottom view of the EBG embedded antenna which shows the position of the slots beneath the microstrip line. The parameters used in the design of the antenna as well as that of the EBG structure are already discussed in the previous chapters. A 7×11 array of the EBG unit cell is used in the design

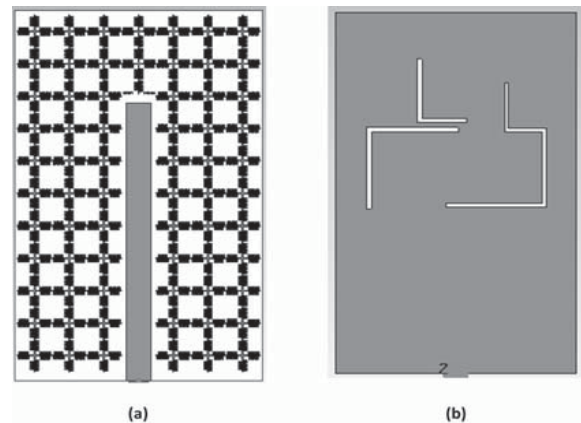

Figure 2.1: Antenna with the EBG (a) Top view (b) Bottom view

2.2.2 Results and discussions

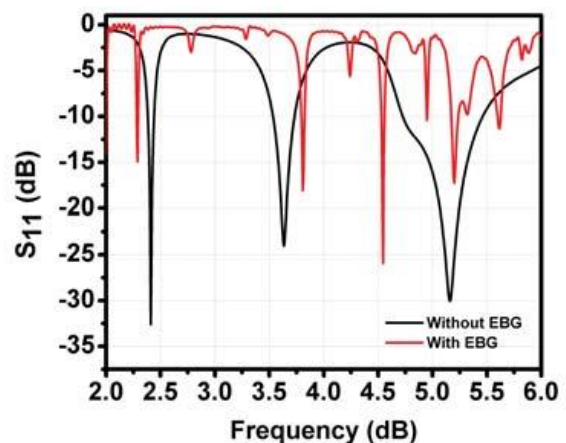

Figure 2.2: S_{11} comparison of the antenna with and without EBG

Figure 2.2 shows the comparison of the S_{11} parameter of the antenna with and without the integration of the EBG. As clearly seen the bands are shifted slightly from their initial position as it happens normally after the application of the EBG. Some of the additional bands appear after the integration of the EBG, these are nothing but the multiple excitation frequencies of the slots.

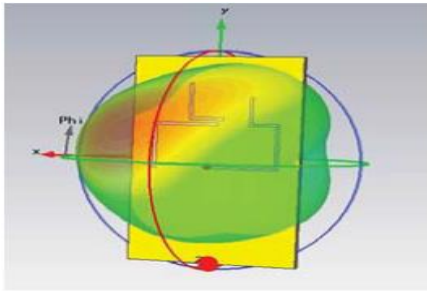

Figure 2.3: Farfield at 2.28 GHz

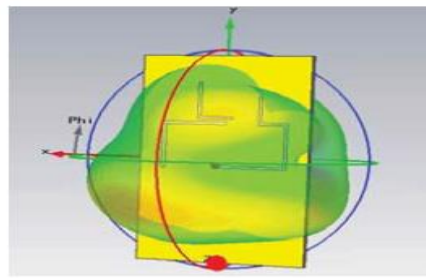

Figure 2.3: Farfield at 3.808 GHz

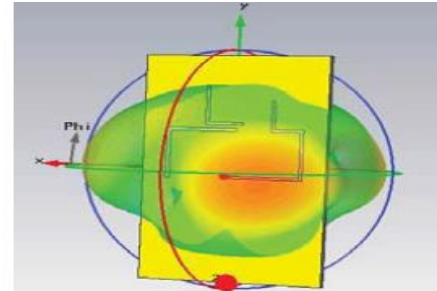

Figure 2.3: Farfield at 5.2 GHz

Fig. 2.3, 2.4, 2.5 shows the farfield patterns of the antenna with the EBG. The antenna is still bidirectional and radiates in both the directions. The antenna gain is enhanced in the band of WiMAX (3.6 GHz) and the WLAN band (5.2 GHz) as the bandgap of the antenna comes in these two frequencies.

The gain of the antenna is shown in table 2.1.

Table 2.1: Gain enhancement of the multiband antenna

Operating Frequency (GHz)	Gain(dB)
2.29	3.50
3.78	4.20
5.20	6.19

II. CONCLUSION

The integration of the EBG shifts the operating frequency of the multiband antenna a little. But due to the suppression of propagation of the surface waves, the introduction of the EBG into the antenna structure enhances the gain of the antenna at the operating frequencies. Since the Band Gap of the EBG comes in the range of WiMAX (3.6 GHz) and the WLAN (5.2 GHz), the considerable gain enhancement of nearly 1db and 2db respectively is achieved.

REFERENCES

- [1] A. AzARI, *A new super wideband fractal microstrip antenna*, IEEE TRANSACTIONS ON ANTENNAS AND PROPAGATION, 59 (2011), pp. 1724-1727.
- [2] C. BALANIS, *Antenna theory analysis and design*, John Wiley and Sons Inc., Wiley, 2005.
- [3] S. BHAVSAR AND P. B. SINGH, *Electromagnetic band gap structures incorporated in antenna array: A review*, International Journal of Computer Technology and Electronics Engineering (IJCTEE), 3.
- [4] H. CHOO AND H. LING, *Design of multiband microstrip antennas using a genetic algorithm*, IEEE MICROWAVE AND WIRELESS COMPONENTS LETTERS, 12 (2002), pp. 345-347.
- [5] B. G. ET AL, *Miniaturization of sot antennas using slit and strip loading*, IEEE TRANSACTIONS ON ANTENNAS AND PROPAGATION, 59 (2011), pp. 3922-3927.
- [6] B.-Q. L. ET AL, *Uniplanar ebg structure with improved compact and wide-band characteristics*, Electronic letters, 44 (2008), pp. 1362-1363.
- [7] C. P. ET AL., *Fractal multiband antenna based on the sierpinski gasket*, ELECTRONICS LETTERS, 32 (1996), pp. 1-2.
- [8] C. P. ET AL, *Perturbation of the sierpinski antenna to allocate operating bands*, ELECTRONICS LETTERS, 32 (1996), pp. 2186-2188.
- [9] C. P.-B. ET AL., *On the behavior of the sierpinski multiband fractal antenna*, IEEE TRANSACTIONS ON ANTENNAS AND PROPAGATION, 46 (1998), pp. 517-524
- [10] D. H. S. ET AL, *Microstrip antennas with frequency agility and polarization diversity*, IEEE TRANSACTIONS ON ANTENNAS AND PROPAGATION, 29 (1981), pp. 118-123.

- [11] D. H. W. ET AL., *Genetically engineered multiband fractal antennas*, ELEC- TRONICS LETTERS, 37 (2001), pp. 1150-1151.
- [12] D. S. H. ET AL., *Millimeter-wave dual-band microstrip patch antennas using multilayer gas technology*, IEEE TRANSACTIONS ON MICROWAVE THEORY AND TECHNIQUES, 44 (1996), pp. 1590-1593.
- [13] E. R.-I. ET AL., *Multiband srr loaded rectangular waveguide*, IEEE TRANSACTIONS ON ANTENNAS AND PROPAGATION, 57 (2009), pp. 1570-1574.
- [14] F. Y. ET AL, *Wide-band e-shaped patch antenna for wireless communications*, IEEE TRANSACTIONS ON ANTENNA AND PROPAGATION, 49 (2001), pp. 1094-1100.
- [15] G. H. ET AL, *Design of the ltcc tooth-like-slot antenna*, International Conference on Microwave and Millimeter Wave Technology Proceedings, (2004), pp. 23-26.
- [16] H. ET AL, *An microstrip antenna array formed by microstrip line fed tooth-like-slot patches*, IEEE TRANSACTION ON ANTENNAS AND PROPAGATION, 55 (2007), pp. 1210-1214.
- [17] I. S. ET AL, *Microstrip patch antenna and its applications: A survey*, Int. J. Comp. Tech. Appl., 2 (2011), pp. 1595-1599.
- [18] K. F. L. ET AL., *Dual- and multiband u-slot patch antennas*, IEEE ANTENNAS AND WIRELESS PROPAGATION LETTERS, 7 (2008), pp. 645-647.
- [19] K. L. ET AL, *Design of a wideband microstrip bowtie patch antenna*, IEE Proc.-Microw. Antennas Propag, 145 (1998), pp. 137-140.
- [20] K. L. W. ET AL., *A low-profile planar monopole antenna for multiband operation of mobile handsets*, IEEE TRANSACTIONS ON ANTENNAS AND PROPAGATION, 51 (2003), pp. 121-125.
- [21] L. Y. ET AL., *A novel compact electromagnetic-bandgap (ebg)structure and its applications for microwave circuits*, IEEE TRANSACTIONS ON MICROWAVE THEORY AND TECHNIQUES, 53 (2005), pp. 183-190.
- [22] M. M. ET AL, *Dual layer stacked rectangular microstrip patch antenna for ultra wideband applications*, IET Microw. Antennas Propag., 1 (2007), pp. 1192-1196.
- [23] M. S. A. ET AL, *Development of electromagnetic band gap structures in the perspective of microstrip antenna design*, International Journal of Antennas and Propagation, 2013 (2013), pp. 1-22.
- [24] P. C. ET AL., *Design of an internal quad-band antenna for mobile phones*, IEEE MICROWAVE AND WIRELESS COMPONENTS LETTERS, 14 (2004), pp. 148-150.
- [25] P. R. ET AL, *Multiband microstrip-fed right angle slot antenna design for wireless communication systems*, ETRI Journal, 31 (2009), pp. 271-281.
- [26] R. C. H. ET AL., *Compact multiband planar monopole antennas for smart phone applications*, IET Microwaves, Antennas and Propagation, 2 (2007), pp. 473-481.
- [27] S.-H. W. ET AL, *Wideband microstrip patch antenna with u-shaped parasitic elements*, IEEE TRANSACTIONS ON ANTENNA AND PROPAGATION, 55 (2007), pp. 1196-1199.
- [28] W. C. L. ET AL., *Triple-frequency meandered monopole antenna with shorted parasitic strips for wireless application*, IET Microwaves Antennas and Propagation, 3 (2008), pp. 1110-1117.
- [29] X. J. ET AL., *A compact multiband planar antenna for mobile hand- sets*, IEEE ANTENNAS AND WIRELESS PROPAGATION LETTERS, 5 (2006), pp. 343-345.
- [30] Y. X. G. ET AL., *Compact internal multiband antennas for mobile hand- sets*, IEEE ANTENNAS AND WIRELESS PROPAGATION LETTERS, 2 (2003), pp. 143-146