

Investigating the Significance of Alamouti Code Transmission Scheme on the Performance of Modify MRC Receiver

Abdulahi Abiodun Badrudeen, Olumide O. Ajayi, Abideen Amosa Akanni, Oluwaseun A. Ojo

Abstract— This paper presents a joint orthogonal space time block coding (OSTBC) with modified maximum ratio combiner (MRC) for correcting intersymbol interference distortion in mobile wireless channel. Alamouti code (OSTBC) scheme is adopted instead of the beamforming scheme to address the hardware complexity due to RF chain and matched-filter in general MIMO because it does not require the channel knowledge at the transmitter. The system is simulated using MATLAB to investigate the effect of OSTBC scheme on the performance of a modified MRC. Results show that OSTBC performance is significant only when the combining diversity is order n by n .

Index Terms— Alamouti Code, Matched Filter, Maximum Ratio Combiner, MPSK, RF chain

I. INTRODUCTION

Diversity scheme is one of the approaches currently in use to achieve higher reliability as well as spatial multiplexing in wireless cellular system. Diversity combining schemes such as equal gain combining, selective combining and maximum ratio combining [1] have been used in literature to detect the multipath signal in order to mitigate the multipath effect of which MRC has been identified as the best among its counterparts[2]. Multi-path propagation produced by reflection, refraction or diffraction of the signals on objects placed in the medium resulting in signals being combined constructively in some places and destructively in others [3]. Signal fading phenomenon occurs when the received signal power strength is so severed such that it is difficult to produce a signal which is below the sensitivity of the receiver, thus causing poor reception of the signals. Delay spread is the time spread between the arrival of the first and last multipath signal seen by the receiver.

In a digital mobile wireless system, the delay spread can lead to inter-symbol interference (ISI) which occurs whenever the received multipath components of a symbol extend beyond the symbol's time duration [4]. The fading channel associated with ISI is called frequency-selective, where the bandwidth occupied by the channel is large enough that the frequency response of the channel varies over that range. But when there is no ISI, the fading channel is time-selective because information transmitted through it may change over time [5]. Doppler spread is the spread of the frequency spectrum of the received signal with respect to that of the transmitted signal when there is relative

motion between the transmitter and the receiver. This is due to the different angles of arrival associated with the propagation paths [4].

Conventional MRC is characterised with hardware complexity because each of the receive antenna is dedicated to each radio frequency (RF) chain and matched filter as in [3] and Sang and [6]. Therefore, it consumes more power and its implementation cost is high. Figure 1 is the conventional MRC and it can be observed that the MRC is implemented at the baseband stage. In [7] a modify MRC diversity scheme with one RF chain and match filter regardless of the number of multipath to mitigate the effect of delay spread and Doppler spread in an ISI induced channel is proposed. Hilbert transformation of all the received multipath signals in each of the paths were performed at the RF stage before combining made the realisation of MRC with one RF chain and one Matched filter possible after combining. The modify MRC is implemented at the RF stage. Simulation results show that modified MRC performed better than the conventional MRC. The signal processing time of the modify MRC also gave a better performance as against the conventional MRC. This investigation is carried out under the assumption of a SIMO system.

The method adopted in [7] cannot be directly applied in a MIMO system in order to reduce the RF chain to one, but with an exemption of beamforming scheme used. Using beamforming scheme in [6] has been shown as the optimal transmitting scheme but the channel knowledge must be known at the transmitter which is not practicable without channel estimation. Therefore, this paper proposes an OSTBC scheme at the transmitter in order to make the modified MRC with one RF chain and matched filter realisable with the hope of improving the system performance in MISO and general MIMO systems. Simulation results are compared to the results obtained in [7] where SIMO system is investigated without OSTBC and the SISO (no diversity scheme) to show the significant of diversity scheme in the performance of the wireless system.

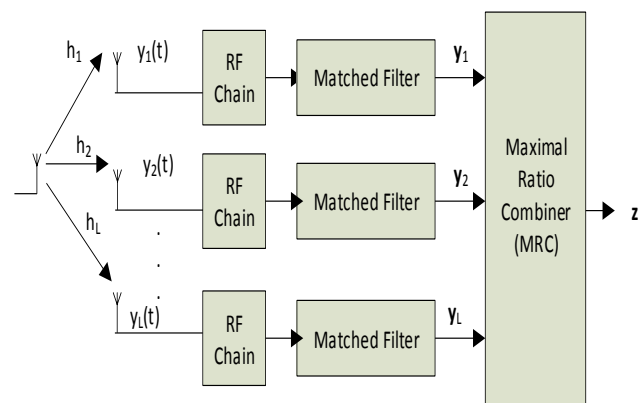

Figure 1. Conventional baseband MRC

Abdulahi Abiodun Badrudeen Student Member IEEE, Dept. of Computer Engineering, Federal Polytechnic Ede

Olumide O. Ajayi, Dept. of Elect. and Elect. Engin., Adeleke University Ede

Abideen Amosa Akanni, Dept. of Computer Engineering, Federal Polytechnic Ede

Oluwaseun A. Ojo, Dept. of Computer Engineering, Federal Polytechnic Ede

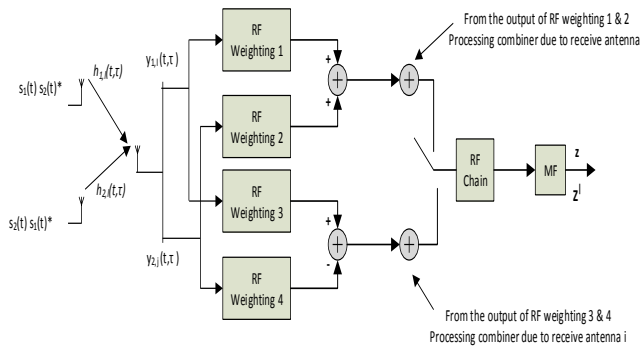

Figure 2. Proposed modify MRC receiver for OSTBC signal

II. SYSTEM MODEL

The system model for a MISO is modeled as in Figure 2. The MISO model is scalable to MIMO by adding receive antenna 1 where $l = 2, 3, \dots, L$ and the RF weighting processing for additional receive antenna is repeated as in the antenna 1. RF weighting consists of Hilbert transformer which performs hilbert transformation operation on the receive RF signal. Source data (1,000 randomly generated binary data) are reshaped and modulated with BPSK and QPSK signaling schemes and transmitted using alamouti (OSTBC) signaling scheme via the two transmitting antennas. The channel is model as Rayleigh fast and frequency selective to evaluate the effect of delay spread and relative mobility between the transmitter and the receiver. The channel impulse response of the mobile wireless channel is assumed and will be model using Jakes model as in (1) and (2) [7]

$$h(t, \tau) = \sum_{i=0}^{L-1} a_i(t, \tau) e^{j\theta_i(t, \tau)} \delta(\tau - \tau_i), \quad (1)$$

where the δ is the Dirac delta function and $a_i(t, \tau)$ is the attenuated amplitude at time t and delay τ . The phase term is represented by a single variable and can be expressed as

$$\theta_i(t, \tau) = -2\pi f_c \tau_i(t) + \phi(t - \tau_i(t)), \quad (2)$$

The received RF signals at the l^{th} receive antenna are $\tilde{y}_{l,1}(t)$ and $\tilde{y}_{l,2}(t)$ in two consecutive symbol intervals express as:

$$\tilde{y}_{l,1}(t) = Re \left\{ \begin{bmatrix} h_{l,1}(t, \tau) s_1(t) + \\ h_{l,1}(t, \tau) s_2(t) + n_{l,1}(t) \end{bmatrix} e^{j2\pi f_c t} \right\}, \quad (3)$$

$$\tilde{y}_{l,2}(t) = Re \left\{ \begin{bmatrix} -h_{l,1}(t, \tau) s_2^*(t) \\ +h_{l,2}(t, \tau) s_1^*(t) + n_{l,2}(t) \end{bmatrix} e^{j2\pi f_c t} \right\}, \quad (4)$$

Where $h_{l,k}(t, \tau)$, $k = 1, 2$, is the complex Gaussian channel gain between the k^{th} transmitting antenna and the l^{th} receive antenna, and $n_{l,1}(t)$ and $n_{l,2}(t)$ are the complex Gaussian white noise at the l^{th} receive antenna. s_1 and s_2 are transmitted signals from transmitting antenna one and two respectively. After taken the conjugate of (4), it can be written as

$$\tilde{y}_{l,2}(t) = Re \left\{ \begin{bmatrix} -h_{l,2}^*(t, \tau) s_1(t) \\ +h_{l,1}^*(t, \tau) s_2(t) + n_{l,2}^*(t) \end{bmatrix} e^{j2\pi f_c t} \right\}, \quad (5)$$

Channel coefficients in (3) and (5) will be chosen to make \bar{C}_1 and \bar{C}_2 matrices orthogonal.

$$\begin{bmatrix} \tilde{y}_{l,1} \\ \tilde{y}_{l,2} \end{bmatrix} = Re \left\{ \begin{bmatrix} h_{l,1} & h_{l,2} \\ h_{l,2}^* & -h_{l,1}^* \end{bmatrix} \begin{bmatrix} S_1 \\ S_2 \end{bmatrix} + \begin{bmatrix} n_{l,1} \\ n_{l,2} \end{bmatrix} \right\}, \quad (6)$$

$$\bar{y} = (\bar{c}_1 s_1 + \bar{c}_2 s_2 + \bar{n}) e^{j2\pi f_c t}, \quad (7)$$

where $\bar{c}_1^H \times \bar{c}_2 = 0$ shows the orthogonality of the channel coefficient. The output of the RF weighting 1 and 2 blocks can be expressed as:

$$\tilde{\omega}_{l,1}(t) = Re \left\{ \begin{bmatrix} h_{l,1}^* h_{l,1} s_1(t) \\ +h_{l,1}^* h_{l,2} s_2(t) + h_{l,1}^* n_{l,1} \end{bmatrix} e^{j2\pi f_c t} \right\}, \quad (8)$$

$$\tilde{\omega}_{l,2}(t) = Re \left\{ \begin{bmatrix} -h_{l,1}^* h_{l,2} s_2(t) \\ +h_{l,2}^* h_{l,1} s_1(t) + h_{l,2}^* n_{l,2} \end{bmatrix} e^{j2\pi f_c t} \right\}, \quad (9)$$

by combining the output of RF weighting 1 and 2 with summer, we obtained:

$$\tilde{\omega}_l(t) = Re \left\{ \begin{bmatrix} (|h_{l,1}|^2 + |h_{l,2}|^2) s_1(t) \\ +h_{l,1}^* n_{l,1}(t) + h_{l,2}^* n_{l,2}(t) \end{bmatrix} e^{j2\pi f_c t} \right\}, \quad (10)$$

when down converting (10) using RF chain we obtained:

$$z(t) = \sum_{i=1}^L \left[\begin{bmatrix} (|h_{l,1}|^2 + |h_{l,2}|^2) s_1(t) \\ +h_{l,1}^* n_{l,1}(t) + h_{l,2}^* n_{l,2}(t) \end{bmatrix} \right], \quad (11)$$

Signal to Noise Ratio (SNR) can be expressed as:

$$SNR = \sum_{i=1}^L \frac{(|h_{l,1}|^2 + |h_{l,2}|^2) \mathbb{E}[s_1(t)^2]}{N_o}, \quad (12)$$

Similarly, we carry out Hilbert transform on are $\tilde{y}_{l,1}$ and $\tilde{y}_{l,2}$ to RF weighting 3 and 4 blocks respectively to obtain

$$\tilde{\omega}_{l,3}(t) = Re \left\{ \begin{bmatrix} |h_{l,2}|^2 s_2(t) + h_{l,1} h_{l,2}^* s_1(t) + h_{l,2}^* n_{l,1} s_1(t) \end{bmatrix} e^{j2\pi f_c t} \right\}, \quad (13)$$

$$\tilde{\omega}_{l,4}(t) = Re \left\{ \begin{bmatrix} -|h_{l,1}|^2 s_2(t) + h_{l,1} h_{l,2}^* s_1(t) + h_{l,1}^* n_{l,2} s_1(t) \end{bmatrix} e^{j2\pi f_c t} \right\}, \quad (14)$$

Subtracting (14) from (13) to obtain the output of the combiner

$$\tilde{\omega}'_l(t) = Re \left\{ \begin{bmatrix} (|h_{l,1}|^2 + |h_{l,2}|^2) s_2(t) + h_{l,2}^* n_{l,1}(t) - \\ h_{l,1} n_{l,2}^*(t) \end{bmatrix} e^{j2\pi f_c t} \right\}, \quad (15)$$

then $\tilde{\omega}'_l(t)$ is down-converted to obtain z' as

$$z' = \sum_{i=1}^L \left[\begin{bmatrix} (|h_{l,1}|^2 + |h_{l,2}|^2) s_2(t) + h_{l,2}^* n_{l,1}(t) - \\ h_{l,1} n_{l,2}^*(t) \end{bmatrix} \right], \quad (16)$$

Therefore we obtain SNR for (17) as

$$SNR = \sum_{i=1}^L \frac{(|h_{l,1}|^2 + |h_{l,2}|^2) \mathbb{E}[s_2(t)^2]}{N_o}, \quad (17)$$

which shows the diversity order of $2L$ and the SNR is similar to that of conventional MRC that uses L RF chains and L MFs

III. SIMULATION RESULTS

In this section we provide simulation results for the proposed OSTBC transmission scheme with modified MRC receiver using MPSK signaling scheme with $M = 2, 4$ for BPSK and QPSK respectively in MISO and MIMO mobile wireless system at a mobile speed of 30 km/h. These results are compared with the SISO and SIMO without OSTBC scheme in [7]. Simulation parameter are set up as follows:

Carrier frequency $f_c = 2.3\text{GHz}$, Coherent wavelength $\lambda_c = 0.1304\text{m}$, Symbol period $T_s = 6.25\text{ms}$, Coherent time $T_c = 2.48\text{ms}$, Bandwidth of the signal $W = 160\text{ kHz}$, Coherent bandwidth $B_c = 100\text{Hz}$, maximum Doppler frequency $f_d = 170.35\text{Hz}$, Number of pilot symbol per frame = 16, number of packets = 3000, SNR = 0 to 20 dB and Transmit and receive filters are square root raised cosine filter and matched squared root raised cosine filter respectively.

BER results of the modulation schemes at a specific mobile station speed.

Figures 3 and 4 are results obtained when BPSK and QPSK are respectively used to modulate randomly generated binary data in a MISO system with OSTBC transmission scheme and modify MRC receiver and compare to the result of no diversity SISO and SIMO receive diversity which has no OSTBC

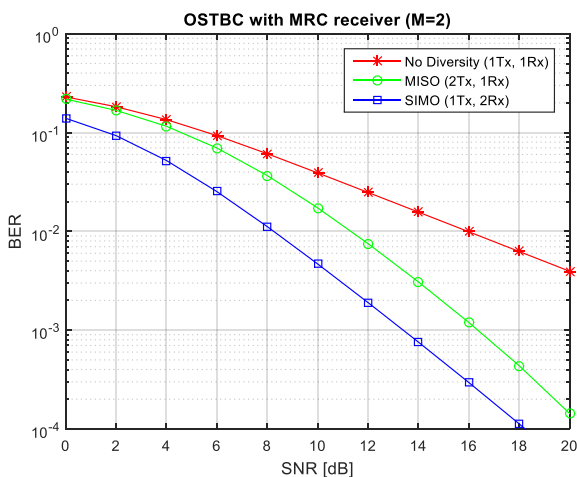

Figure 3. BER of OSTBC with modified MRC for BPSK signal at the mobile speed of 30km/hr

scheme. Results obtained shows that SIMO system with only modify MRC receiver performed best with BPSK and QPSK modulation schemes over the fast and frequency selective mobile fading channel using modified MRC receiver without

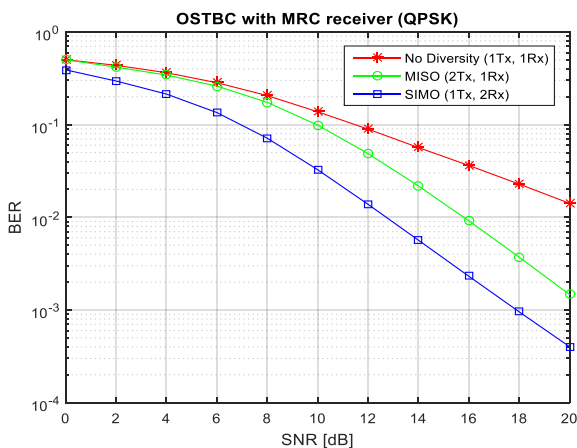

Figure 4. BER of OSTBC with modified MRC for QPSK signal at the mobile speed of 30km/hr

OSTBC at the transmitter as against the MISO systems with OSTBC scheme. This indicates that receive diversity gain in SIMO gives better performance to the system as against the OSTBC scheme compared to MISO systems. In addition, the SNR converged at 18 dB compared to MISO and SISO systems that both converged at 20 dB. This reveals the higher power efficiency of a SIMO system because multiple antenna at the receiving end needs lesser power to detect the signal.

The best BER performance of SIMO compare to the other two receivers was due to highest diversity at the receiver. The SNR of all the three receivers converged at 20 dB. At 0 to 8 dB (lower) SNR, SISO and MISO performances are significantly equal. Therefore, more power is needed to make MISO perform better than SISO. QPSK scheme BER performance is lesser as against the BPSK due to its higher M constellation number which causes constellation error during signal detection. Due to the limitation of space, the readers are refer to the [7] for the BER performances of the conventional MRC and modified MRC.

To clearly observe the effect of doppler shift on the performance of the two modulation schemes in fast and frequency selective Rayleigh fading channel with the proposed modified MRC, simulation was carried out to plot BER against SNR performances of the modulation schemes on the same graph at a particular mobile speed in a MIMO wireless system. This is presented in Figure 5.

It can be observed from Figure 5 that BPSK was more robust to Doppler effect caused by the 30 km/hr mobile speed compared to the QPSK. This is because of the greater euclidean distance (smaller Constellation number) which is directly proportional to the error caused by Doppler effect obtained in the received signal. SNR of BPSK and QPSK converged at 13dB and 17dB respectively. It shows that more power is needed for higher capacity modulation schemes. Also, the BER of QPSK is higher than that of BPSK which makes it less preferred when and where there are relative mobility between the users and base station and when the users prefer quality to capacity. In Figure 5, due to full diversity gain at both transmitter and receiver, MIMO-OSTBC scheme appears to perform best when compare to the SISO, SIMO and MISO in Figures 3 and 4.

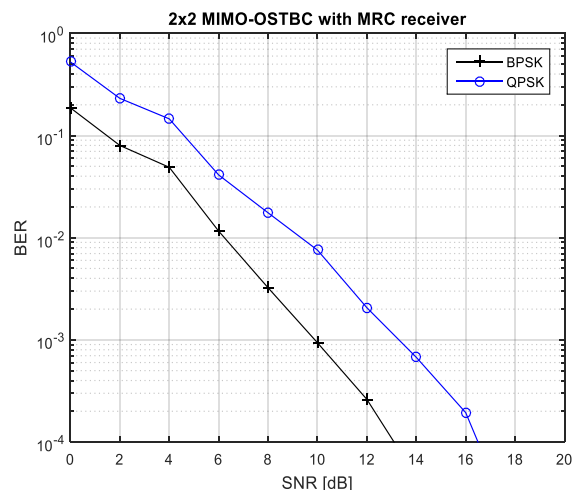

Figure 5. BER performance of BPSK and QPSK at mobile speed of 30km/hr in a 2 by 2 MIMO system.

Figures 6 and 7 are the simulation results that compare the performance of SISO, SIMO with modified MRC, MISO with OSTBC-modified MRC and MIMO with OSTB-modified MRC diversity in a fast and frequency selective Rayleigh fading channel using BPSK and QPSK modulation schemes. MIMO receiver gave the lowest BER from 2 dB to 20 dB SNR with an

exemption of 0 dB SNR which has a higher BER when compared to SIMO receiver. Figures 6 and 7 have revealed the effect of OSTBC on the signal propagation, that the OSTBC codes causes the optimum performance on the communication system when there are multiple antennas at the transmitter and receiver. This is the highest diversity gain scenarios.

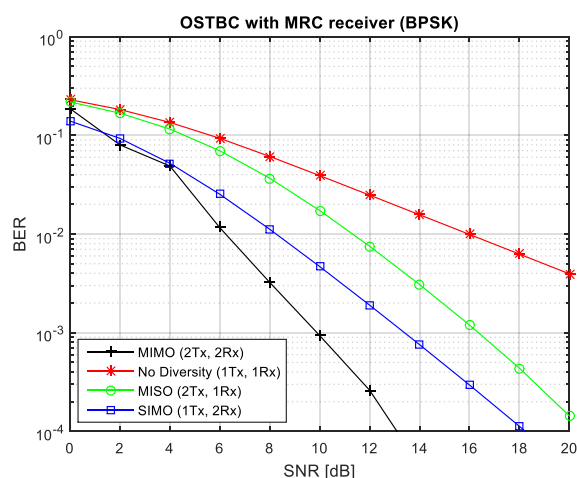

Figure 6. Performances comparison of SIMO, MISO and MIMO using BPSK

IV. CONCLUSION

We have investigated the performance of OSTBC transmission scheme and modified MRC receiver in a SISO, SIMO and MIMO wireless systems. The system model is developed and simulated with MATLAB to evaluate the BER performance of the systems using BPSK and QPSK at a mobile speed of 30 km/h. It was discovered that the OSTBC scheme gave the best performance when the diversity order is square in both the modulation scheme and lesser performance when compared to the SIMO without OSTBC. Generally, the joint OSTBC, with modified MRC schemes has shown a robust performance against the multipath effects of a Rayleigh fast and frequency selective fading channel.

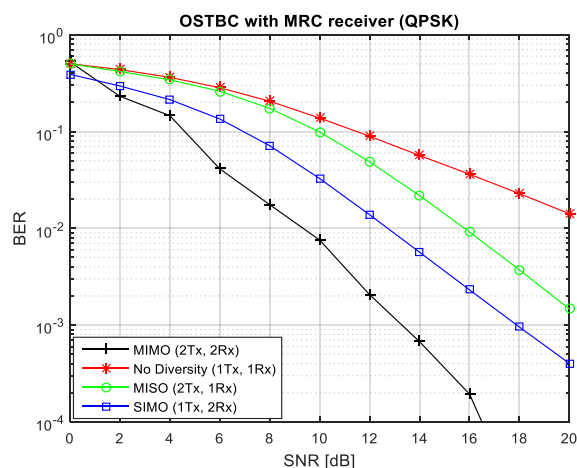

Figure 7. Performances comparison of SIMO, MISO and MIMO using QPSK

REFERENCES

[1] Chen, Z., Yuan, J. and Vucetic, B. Analysis of transmit antenna selection/maximal-ratio combining in Rayleigh fading channels. *IEEE Transactions on Vehicular Technology*, 2005. 54(4): 1312–1321.
 [2] Alouini, M.-S. and Goldsmith, A. J. Capacity of Rayleigh fading channels under different adaptive transmission and diversity-combining

techniques. *IEEE Transactions on Vehicular Technology*, 1999. 48(4): 1165–1181.
 [3] Adeyemo, Z. and Abolade, R. Comparative Analysis of Gaussian Minimum Shift Keying and Binary Differential Phase Shift Keying Signalling Schemes with Maximal Ratio Combiner over Rayleigh Environment. *Advanced Materials Research. Trans Tech Publ.* 2012, vol. 367. 205–214.
 [4] Sklar, B. Rayleigh fading channels in mobile digital communication systems. I. Characterization. *IEEE Communications magazine*, 1997. 35(9): 136–146.
 [5] Liu, Z., Ma, X. and Giannakis, G. B. Space-time coding and Kalman filtering for time-selective fading channels. *IEEE Transactions on Communications*, 2002. 50(2): 183–186.
 [6] Kim, S. W. and Wang, Z. Maximum ratio diversity combining receiver using single radio frequency chain and single matched filter. *Global Telecommunications Conference, 2007. GLOBECOM'07. IEEE. IEEE.* 2007. 4081–4085.
 [7] Adeyemo, Z. K., Badrudeen, A. A. and Abolade, R. O. Intersymbol Interference Distortion Cancellation Using Modified Maximal Ratio Combiner in Mobile Wireless Communication. *Journal of Information Engineering and Application*, 2013. 3(8).