

Investigation of Compressive Properties of Wollastonite (CaSiO₃) reinforced Acrylonitrile Butadiene Styrene composites

Prapul Chandra A C, Dr. H V Byregowda, Gangadhar T G, Mohammed Ayoob Khan

Abstract— This paper describes the influence of the filler material on compressive properties of acrylonitrile butadiene styrene composites. It possesses more compression strength than other plastic materials like Nylon6 and hence an effort has been made to further increase the compressive strength by the inclusion of Wollastonite. Acrylonitrile butadiene styrene is reinforced with Wollastonite and test specimens are prepared as per ASTM D695 standards. Tests were conducted on different percentage 3, 5, and 7 wt. % of Wollastonite in acrylonitrile butadiene styrene and pure acrylonitrile butadiene styrene. The compressive strength leads to improve up to 5 wt. % of Wollastonite acrylonitrile butadiene styrene composites and further addition of Wollastonite (7 wt. %) that reduction in the compression strength of the acrylonitrile butadiene styrene composite.

Index Terms— Wollastonite (Calcium Silicate), Acrylonitrile Butadiene Styrene (ABS), Compressive strength.

I. INTRODUCTION

Wollastonite (CaSiO₃) is calcium inosilicate mineral containing small amounts of magnesium, iron, and manganese substituting for calcium, white in colour. It forms when impure limestone is subjected to high pressure and temperature sometimes in presence of silica-bearing fluids as in skarns or contact metamorphic rocks.

Wollastonite has importance in industrial applications worldwide. It is used in many industries, most often by tile factories which have integrated it into the manufacturing of ceramic, metallurgy, paint filler, friction products etc. [1] so as to improve many performance parameters, and this is because of its fluxing properties, whiteness, freedom from volatile constituents, and sharp and pointy particle shape. When used in ceramics,

Wollastonite decreases its shrinkage and evolution of gas during firing, increases green, fired strength, permits fast firing, maintains brightness during firing, reduces cracking, crazing, and glaze defects. In metallurgical applications, wollastonite serves as a welding flux, a slag conditioner, a source for calcium oxide, and to protect the molten metal surface during continuous steel casting. It is used as an additive in paint, due to increase in durability and improves resistance to weather and it acts as a pH buffer, reduces pigment consumption, gloss and acts as a suspending and

Prapul Chandra A C, Assistant Professor, R V College of Engineering, Bengaluru, Karnataka

Dr. H V Byregowda, Professor, Ghousia College of Engineering, Ramanagara, Karnataka

Gangadhar T G, Assistant Professor, SJBIT, Bengaluru, Karnataka

Mohammed Ayoob Khan, PG Student, R V College of Engineering, Bengaluru, Karnataka

flattening agent. In plastics, wollastonite improves compressive, flexural and tensile strength, reduces resin consumption, improves dimensional and thermal stability at elevated temperatures. By using these additives it is possible to alter the properties of polymers to required level and conditions. [2,3]

Acrylonitrile Butadiene Styrene (ABS) is a polymer and opaque thermoplastic. Thermoplastics become liquid (have a “glass transition”) at a certain temperature (105 degrees Celsius in the case of ABS polymer). ABS liquefy, which allows them to attain semi liquid state that can be easily injection moulded and subsequently recycled. In contrast, thermosets can only be heated only once (during the injection moulding). ABS polymer is also an amorphous material that is it does not exhibit the characteristics of crystalline solids. ABS material is commonly polymerized through process of emulsion. A well-known example of an emulsified product is milk. ABS is also created, although less commonly by a patented process that is continuous mass polymerization. Around the world, the commonly used methodology to create ABS is the emulsion process. The important character of ABS to note is that because ABS is a thermoplastic, it can be easily recycled as the other thermoplastic materials. This indicates that a most common way of producing ABS plastic is from other ABS plastic (i.e. making ABS from ABS) [4]

II. EXPERIMENTAL:

The specimen preparation for raw ABS and ABS/Wollastonite specimen has been done as shown in the Fig.

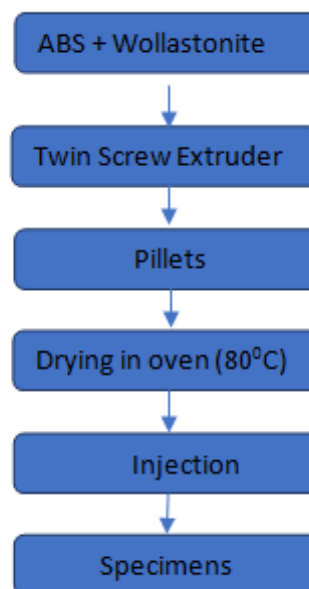

Figure 1: process chart

Investigation of Compressive Properties of Wollastonite (CaSiO₃) reinforced Acrylonitrile Butadiene Styrene composites

Specimen preparation:

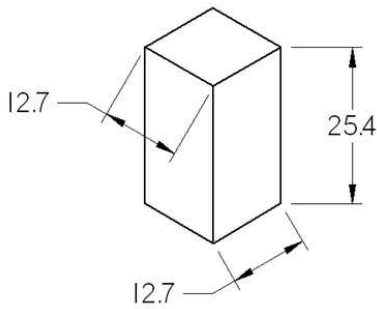

Figure 2: Compression test sample dimension according to ASTM standard

RAW ABS: Raw ABS specimens are prepared using Injection moulding technique. Raw ABS is taken in to injection Moulding machine fitted with a master mould cavity for compression specimen. The machine operates at the pressure of 65 kg/cm² and temperature of about 180-220°C. After the ejection from the mould, specimens were air dried for a few minutes.

ABS/Wollastonite Specimen: Raw ABS is mixed with Wollastonite in proportion of 3%, 5% and 7% to the overall weight. The mixing is done with twin screw extruder of model TUE1 at wood institute, Bangalore which ensures homogeneous mixture of ABS with the filler material. The mixture received from the extruder is in the form of long wires that are later cut into small pellets. These pellets are dried in an air circulated oven at 80°C for 24 hours. Later the pellets are taken into the injection Moulding machine fitted with a master mould cavity for compression specimen. The machine operates at the pressure of 65 kg/cm² and temperature of about 180-220°C. After the ejection from the mould, specimens were air dried for a few minutes. The whole injection moulding process was carried out at Nagendra Enterprises, Bangalore.



Figure 3(a): Twin screw extruder



Figure 3(b): Injection moulding



3(c): image of UTM

Testing: The compression test on ABS and its composites are measured by using a Universal Testing Machine (model: TUE-C-400) of 10 T capacity. The Compression test is carried in accordance with ASTM D695 standard. Specimens of dimensions 12.7 x 12.7 x 25.4 mm used in the study (Figure 2). The specimen is mounted in between the compression plates. The test is carried out by initially lowering the movable crosshead at a specified speed of 1.30 mm / min over the specimen. The load carried by the specimen during the test is recorded. The stress and strain are extracted from the load-deflection curves obtained from the tests. The results of the test are denoted as N/mm².

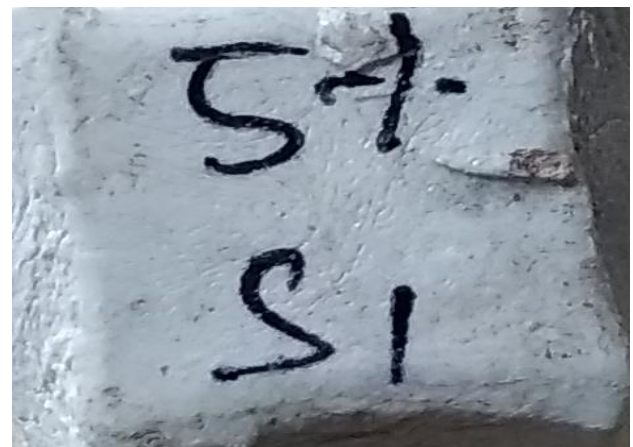

Figure 4: Image of Specimen before fracture



Figure 5: Image of Specimen after fracture

Table 1 Compression test values of ABS and ABS/Wollaston

Samples	ABS		ABS + 3% Casio3		ABS+5% Casio3		ABS+7% Casio3	
	CS (MPa)	Elongation (%)	CS (MPa)	Elongation (%)	CS (MPa)	Elongation (%)	CS (MPa)	Elongation (%)
S1	60	18	63	12.5	100.05	6.9	76.92	9
S2	58.5	19.5	65.1	11	105.67	6	78.19	8.4
S3	59	16.5	66	10	105.98	6.3	78.09	8.7

CS-Compressive Strength, S1, S2, and S3 – Samples

III. RESULTS AND DISCUSSION:

All the samples were tested for different percentage of CaSiO_3 with pure ABS material. The data is recorded for each specimen and the average of best two specimen results are taken as maximum compressive strength. The image of specimen before and after fracture is shown in figure 4 & 5. The specimens under test are classified in to 4 types: Pure ABS specimen, ABS+3% CaSiO_3 , ABS+5% CaSiO_3 , ABS+7% CaSiO_3 . The maximum compressive strength for the entire specimen has been shown in above table 1. The variation of compression strength for different samples of different percentage of CaSiO_3 inclusion in ABS is shown in the graph from figure 6 to 9. It was observed from the stress strain graph that a raw ABS material has compressive strength of 59.5 Mpa and this is low when compared to ABS reinforced calcium silicate.

The inclusion of 3% calcium silicate into the matrix of ABS increases the compressive strength of ABS + 3% CaSiO_3 is 65.55 Mpa. so that compressive strength increased by almost 10% and the elongation percentage of the material becomes low so that it indicates that material nature was being brittleness and some more addition of CaSiO_3 (5%) to raw ABS was observed that again increased in compressive strength and attains 105.825 Mpa and it is increased by 77.20% and elongation percentage got decreased and material becomes still brittle and hard so that it sustain high compression force. further increased in the percentage (7%) of CaSiO_3 to raw ABS it was observed that sudden decreasing in compressive strength and attains 78.09 Mpa. and it is decreasing the strength by 26.20% and elongation percentage of the material got increased. The decreasing of compressive strength as the percentage of CaSiO_3 due to poisoning effect of CaSiO_3 in ABS and the particles acts as source of imperfection.[5]

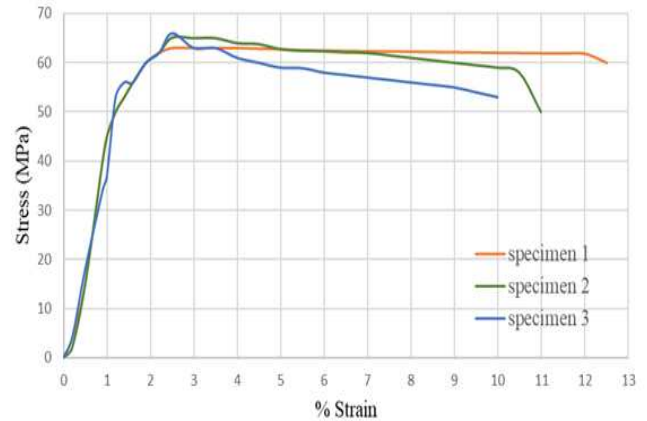

Figure 7: Graph of Stress Vs Strain for ABS + 3% CaSiO_3 material

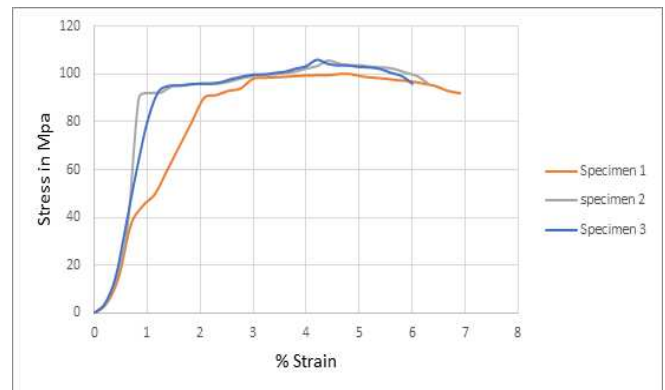

Figure 8: Graph of Stress Vs Strain for ABS + 3% CaSiO_3 material

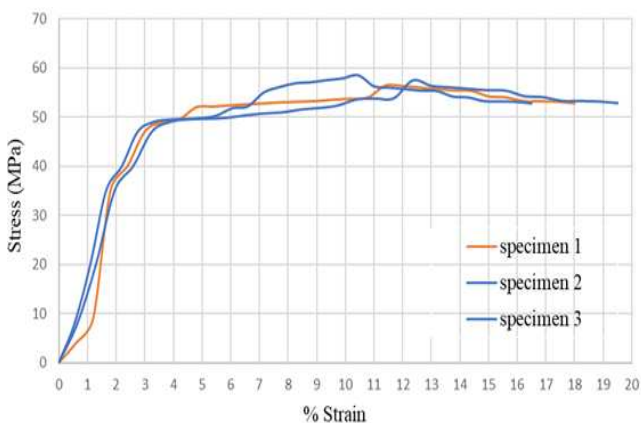

Figure 6: Graph of Stress Vs Strain for Pure ABS material

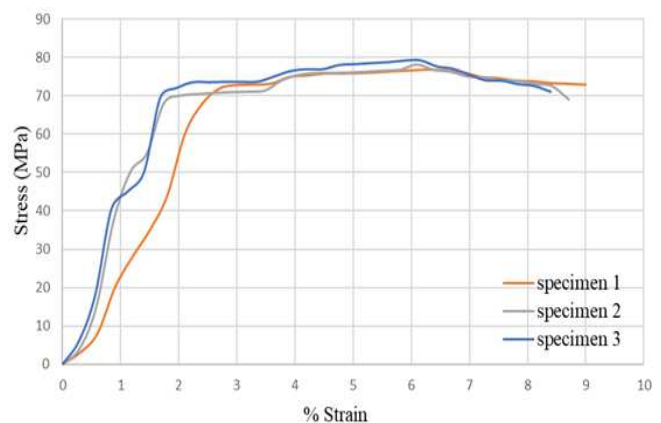

Figure 9: Graph of Stress Vs Strain for ABS + 7% CaSiO_3 material

Investigation of Compressive Properties of Wollastonite (CaSiO₃) reinforced Acrylonitrile Butadiene Styrene composites

IV. CONCLUSION:

The ABS reinforced with varying Percentage of CaSiO₃ were tested under compressive loading with the following conclusions:

- As the inclusion of CaSiO₃ in to the matrix of ABS increases the compressive strength of the material also increase but it is limited to 5% of CaSiO₃ with ABS and further increase in the percentage (7%) of CaSiO₃ to raw ABS it was observed that sudden decreasing in compressive strength and attains 78.09 Mpa.
- As the incorporation of CaSiO₃ in to the matrix of ABS increases the % elongation of the material decreases and it again get increases after the 7% of CaSiO₃ with pure ABS

REFERENCES

- [1] <http://www.canadianwollastonite.com/wollastoniteproperties.htm>
- [2] penttjarvela et al. " polyamide 6/wollstanite composites strength properties and their dependence on humidity and temperature' journal of material science 21 (1986) 4193-4198
- [3] R. A Clifton , "mineral fillers used in the plastic industry", SME-AIME annual Meeting, New York, 24-28 February (Littleton, Colorado,1985)
- [4]<https://www.creativemechanisms.com/blog/everything-you-need-to-know-about-abs-plastic>.
- [5] Mithun V Kulkarni et al. Flexural properties of Calcium meta silicate reinforced polyamides.2013