

PUBLIC-PRIVATE PARTNERSHIPS IN IMPLEMENTATION OF GERBANGMASTRA PROGRAM

La Ode Mustafa Muchtar*

Graduate School of Gadjah Mada University
e-mail: laodemustafa21@gmail.com

Nunung Prajarto

Graduate School of Gadjah Mada University

Subejo

Graduate School of Gadjah Mada University

Abstract

This research attempts to describe and analyze the effect of public-private partnerships and community participation on successful of the implementation of Gerbangmastra program in Kolaka regency of South East Sulawesi Province. This study is conducted using a combination of qualitative and quantitative methods. This paper finds that public-private partnerships affect the community participation and successful of the implementation of Gerbangmastra program. It also uncovers that community participation affects the successful of the implementation of Gerbangmastra program. Furthermore, it reveals that the implementation of public-private partnership that are supported by community participation have an impact on the successful of the implementation of Gerbangmastra program.

Keywords: Public private partnerships, community participation, Gerbangmastra program

JEL classifications: H80, O21.

Abstrak

Penelitian ini bertujuan untuk mendeskripsikan dan menganalisis pengaruh kemitraan pemerintah-swasta dan partisipasi dari masyarakat terhadap keberhasilan pelaksanaan program Gerbangmastra di Kabupaten Kolaka Propinsi Sulawesi Tenggara. Penelitian ini dilakukan dengan menggunakan kombinasi metode kuantitatif yaitu metode regresi analisis jalur dan kualitatif berupa metode deskriptif analitik. Hasil penelitian menunjukkan bahwa kemitraan antara pemerintah-swasta memiliki pengaruh terhadap partisipasi masyarakat dan keberhasilan pelaksanaan program Gerbangmastra. Sementara itu partisipasi dari masyarakat berpengaruh terhadap keberhasilan pelaksanaan program Gerbangmastra. Pelaksanaan kemitraan pemerintah-swasta yang didukung oleh partisipasi masyarakat berpengaruh terhadap keberhasilan pelaksanaan program Gerbangmastra di daerah tersebut.

Kata kunci: Kemitraan pemerintah-swasta, partisipasi masyarakat, program Gerbangmastra

JEL classifications: H80, O21.

INTRODUCTION

The rural development is an integral part of local and national developments as an ef-

fort to improve the quality of life of the community. Ideally, the programs of rural development could be performed sustainably based on the potential and capabilities of the existing resources. The implementa-

*Corresponding author

tion of rural development programs is very important in the context of regional development. Rural development in the era of regional autonomy needs to be improved through the implementation of community-based development programs.

Rural development covers all aspects of life of the community, carried out in an integrated manner with develop a spirit of self-helping in the form of mutual assistance and supported by organization and community participation. The goal is to improve the welfare rural communities by utilizing the capabilities and potential of existing resources through improved quality of life, skills, and community initiatives. Rural development is also an effort to build community life with emphasis on meeting the basic needs for the community.

In line with the rural development, government policy through Act No. 32 of 2004 on Regional Government, strongly supports the transfer of authority to local government to manage the affairs of governance, development, and society, including rural areas. In an effort to run the mandate of the law of regions autonomy, the local governments are required to implement appropriate development policies so that development goes evenly, especially in rural areas which are still experiencing the development gap compared to urban areas.

The rural development needs to get the main priority from the local government, because in this region there are various underdevelopment conditions, that viewed from the aspects of geography, topography, demography and infrastructure. Rural development should be done with the approach appropriate to the nature and characteristics. Rural development should follow the four major effort, interconnected with each other and constitute the principal strategy of rural development, namely: *First*, economic empowerment of rural communities; *Second*, improve the quality of rural human resources in order to have a reasonable basis to improve and strengthen productivity and competitiveness; *Third*, de-

velopment of rural infrastructure. For rural areas the transportation infrastructure is an absolute necessity, and the *fourth*, build of rural institutions both formal and informal (Syahza, 2007).

Consider the condition of the rural area, the local governments need to allocate substantial funds to conduct rural development programs to accelerate the development and strengthening of community capacity. Strengthening of community capacity aims at educating and encouraging community to have independence in carrying out development. Implementation of development that covers all aspects of life will be successful if in its implementation involving the entire community. One indicator of development success is the community participation (Supriyadi, 2010).

The implementation of local autonomy is the basis for the strengthening of the position and role of society in development. One of the main implications is the change of development model linear to be of participatory development model. This model is a model of development from, by and for the people. This Participatory development model gives priority of development undertaken and managed directly by the local community, as efforts to building community capacity in the form of community empowerment as an attempt to eliminate the problems of poverty and equitable development (Soekamto et al, 2004).

The phenomenon underdevelopment of rural development was often escaped from monitoring of local government, whereas community access to information of development programs is still limited. Development extension by local governments are less effective in reaching the entire community, so that people do not have a chance to channel aspirations. Information gap and communication between local government and the community be causes low of community participation in implementation of development programs. Consequent-

ly not a few program-development programs have failure in achieving development goals.

The communication gap between local governments and the public in terms information of rural development programs is interesting to be studied in depth to the extent of implementation of rural development programs to solve the problems and to achieve the development goals. One model of regional development with a particular focus on rural development is the Gerbangmastra program (prosperous community development movement) that initiated by the Government of Kolaka regency Southeast Sulawesi Province. The implementation of Gerbangmastra program is as an effort to improve the welfare of community.

Gerbangmastra program is realized through the activities of the independent village involving local government agencies, private and community. Targets to be achieved from this Gerbangmastra program is improving public services, economic empowerment, community capacity building through development extension, and foster the spirit of cooperation and mutual assistance in development.

The implementation of the Gerbangmastra program implemented gradually by considering the ability of local government resources, especially development financing. Financial ability to finance regional development programs are limited, the government of Kolaka regency seeking new alternatives that development efforts can be implemented. The government of Kolaka regency do approach of development communication with investors who invest in Kolaka regency to be partners in carrying out the program Gerbangmastra.

The government of Kolaka regency take private agent with background of development gap as a partner, where private parties gain a huge advantage in managing natural resources (mining). Local governments only received little royalty from the private sector through the central government, whereas in community life appears

the social and economic disparities that contradict the existence of private parties that manage natural resources, while the private sector never contribute in the community development.

In addition to partnering with the private party in the implementation of Gerbangmastra program, the Government of Kolaka regency seeks encourage the community participation as a major force in to success of the development goals. Synergy of the local government, the private sector and the community in the implementation of local development programs is a new formula in regional development as a form of development communication of the local government as result the creativity and local initiatives in the era of local autonomy. The development communication approach as an effort to socialize of development programs to the community.

The research aims to describe and analyze the effect of socialization of development program, public-private partnerships, and community participation on effectivity of the implementation of Gerbangmastra program in Kolaka regency. The research hypothesis are formulated as follows: (1) allegedly the public-private partnerships have effect to the successful of the implementation of Gerbangmastra program, (2) allegedly the public-private partnership in the implementation of Gerbangmastra program have effect to the community participation, (3) allegedly the community participation have effect to the successful of the implementation of Gerbangmastra program (4) allegedly the public-private partnership and community participation are simultaneously have effect to the successful of the implementation of Gerbangmastra program.

METHODS

This research uses a combination of quantitative and qualitative approaches which quantitative approach are supported qualitative. Integrating of quantitative and qualita-

tive approaches in understanding a reality gives excellent results, providing more data rich and complementary. Qualitative information to be as scientific as quantitative data.

The data used in this study is the result of a survey of 266 residents (households) in Kolaka regency. Sampling was conducted using technique of random sampling and undertaken to community which to know about the Gerbangmastra program. Determination of respondents conducted purposively, namely the community who are aware of Gerbangmastra program.

Data analysis of this study consisted of qualitative and quantitative analysis. Analysis of data and qualitative information do with descriptive analysis through phases, data reduction or summarize the data relevant to the research focus, display of data, and data conclusions. Quantitative data analysis through path analysis.

Path analysis is the development of a regression analysis, so that regression analysis it can be said as a special form of path analysis. Path analysis was used to analyze the pattern of relationships between variables aim to determine the direct effect and indirect effect a set of independent variables to the dependent variable.

Relationships between the independent variables with the dependent variable and relationship between the independent variables can be formulated in the structural equation. The model used in the analysis of the path constitute part of a structural equation model. In the structural equation, the variation of dependent variable is determined by the variables in the model, in which the independent variable is the starting point in the model.

The criteria of model testing is if the Chi-Square with an error rate (p)>0.05 indicates no effect or not real, meaning that the model fit because there is no difference between the hypothetical model with field data. Conversely, if the Chi-Square with an error rate (p) < 0.05 indicates an effect (real), its meaning the model does not fit

because there is a difference between the hypothetical model with field data. Structurally, the model path diagram of the effectivity of Gerbangmastra program in Kolaka regency can be seen in figure 1.

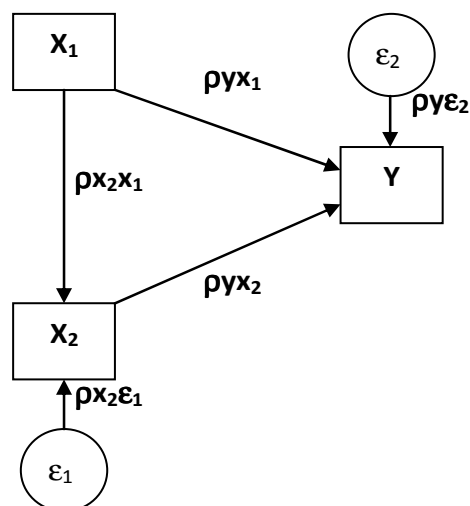

Notes: X_1 is public private partnership, X_2 is community participation, and Y is successful of the implementation of Gerbangmastra program.

Figure 1: The Path Diagram Models of the Effect between Variables

Structural equation of the path diagram is:

$$X_2 = \rho_{x_2x_1} X_1 + \rho_{x_2\epsilon_1} \epsilon_1 \quad (1)$$

$\rho_{x_2x_1}$ constitute a path coefficient that indicates of the direct effect public-private partnerships (X_1) to the community participation (X_2). Whereas $\rho_{x_2\epsilon_1}$ is the effect of other variables to the community participation (X_2) are not identified or investigated.

$$Y = \rho_{yx_1} X_1 + \rho_{yx_2} X_2 + \rho_{y\epsilon_2} \epsilon_2 \quad (2)$$

ρ_{yx_1} constitute a path coefficient that indicates of the direct effect of public private partnerships (X_1) to the successful of the implementation of Gerbangmastra program (Y). ρ_{yx_2} constitute a path coefficient that indicates of the direct effect of community participation (X_2) to the successful of the implementation of Gerbangmastra program

(Y). Where as $\rho\epsilon_2$ is the effect of other variables on the successful of the implementation of Gerbangmastra program (Y) are not identified.

Evaluation of the value of the independent variable path coefficients on the dependent variable that indicates the causal relationship is if critical ratio $>t$ -table at the level of error <0.05 . Analysis of direct effects, indirect effects and total effect was to test the hypothesis. The direct effect is the effect that occurs between independent variables with dependent variable and effect between independent variables indicated by path coefficient at one end of the line arrows. The indirect effect is an effect that comes through an intermediate variable. The total effect is an effect that occurs through direct and indirect effects.

RESULTS

Determinant Factors of Gerbangmastra Program Implementation

Implementation of Gerbangmastra program was initiated by the Government of Kolaka regency as an attempt to resolve the problems of poverty and unemployment. To complete the development problems, the Government of Kolaka regency take strategic steps to implement integrated development model that involves all development components among others the local government, the private sector and communities. The implementation of Gerbangmastra program initiative the government of Kolaka regency.

The government of Kolaka regency is well aware that to complete the problems of development then required large development financing, while the local governments have limited funding, so that the Government of Kolaka regency done communication approach to the private party to explore cooperation the implementation of local development.

The aim of the cooperation is that the private party participates and support

community development activities through the implementation of Gerbangmastra program that initiated by the Government of Kolaka regency in order to realize a prosperous community. Communication the Government of Kolaka regency with private parties resulted in a cooperation agreement in principle the private parties willing to help and support the Government of Kolaka regency in implementing of Gerbangmastra program.

Limitations of development financing be constraint to resolve the development problems so that the implementation of development programs carried out in stages by utilizing other funding sources including private party contributions. Cooperation with the private party in the implementation of development program in Kolaka regency intended for private herding give part of their income from the results exploitation of natural resources Kolaka to resolve the problems of community through the contribution of development financing that managed together the local government and community.

Public-private partnerships in the implementation of Gerbangmastra program has been going on for six years that operationally realized through implementation of operational cooperation and the contribution of resources. Implementation of operational cooperation between the government of Kolaka regency with the private party in the implementation of Gerbangmastra program activities in the community runs good enough. The implementation of operational cooperation is done in an integrated with the community according to the areas of program activities that have been agreed and planned together. Cooperation developed by the Government of Kolaka regency with the private party in the implementation of Gerbangmastra program certainly lead to the creation of mutually beneficial cooperation. Private party involvement with local government which is supported by community participation in the imple-

mentation of Gerbangmastra program asserts that community development work is not only the responsibility of government and the community, but private party also has a role and responsibility of the same.

The realization of resource contributions from both local governments and the private party in the implementation of Gerbangmastra program also runs well. The allocation of this shared resources is the result of a shared commitment between local governments and the private party in supporting the implementation of the various activities of Gerbangmastra programs in the community. Support of resource contributions the private since the implementation of the program includes technical assistance, material aid, assistance of equipment, expert assistance, and assistance of goods or capital. While the support of local government resources namely the financing of program which allocated at budgetary revenue and local expenditure of Kolaka regency through the budget of activities of each regional work units according to the task and functions, personnel support, technical support, equipment support, and administrative support. Utilization of all resources available coordinated by Community Empowerment Board and the Bappeda of Kolaka regency.

Implementation of operational cooperation supported by the allocation of local government resources and private party in the implementation of Gerbangmastra program in Kolaka regency are prioritized at development activities of rural infrastructure and facilities, education, health, social, productive economy, environment, agriculture, livestock and fisheries. Development activity of rural infrastructure and facilities prioritized at development activities of rural roads, asphaltting of village roads, farm roads, street production, bridges, drainage, construction and rehabilitation of irrigation networks, and the development of clean water infrastructure. Achievement of rural infrastructure and

facilities have freed the region of rural in the Kolaka regency from isolated condition, support the mobility of community citizens, and support the smooth of productivity efforts of rural communities, especially the agricultural sector efforts.

Education sector development activities are prioritized at the construction and rehabilitation of school buildings. The construction of education facilities prioritized in remote areas that lack school facilities with condition still many children's do not have the opportunity to follow the proper education and distance of school places which a far make school-age children's in this remote area prone for dropouts. To increase motivation of school children, local government and the private sector also provide assistance in the form-school textbooks and scholarships for outstanding students especially children of poor families. Achievement of education services have freed vulnerable children dropping out of school and to improve learning achievement for students.

Social sector developments are prioritized at housing building activities of the poor community citizens, uninhabitable housing rehabilitation for the poor community citizens. This priority is related with real conditions of community life that most live in rural areas in conditions of limited lives. Social sector development activities is also done through the building and rehabilitation of houses of worship (mosques, churches, and temples), provision of community sports facilities and infrastructure, and the maintenance of public order.

Development and community empowerment activities are prioritized at coaching skills activities for productive workforce, job creation, recruitment of labor for productive workforce to reduce the unemployment rate, venture capital assistance for small and medium businesses, small and medium industrial equipment assistance (tools of carpentry, workshop and sewing machine). The provision of

small and medium enterprises development in the form capital assistance and goods to each business group in each sub-district.

Developing the agricultural sector becomes a priority because it constitutes field of employment at the most labor-absorbing in Kolaka regency. Agricultural development is prioritized at productive farming activities, opening and rehabilitation of plantation land by using mechanization, application of agricultural technology, intensification and rehabilitation of cocoa plants, assistance of agricultural inputs (saprodi), development of rural agribusiness.

Livestock sector development activities is also a priority of local government cooperation with the private party in the implementation of the Gerbangmastra program. Development of livestock sector includes livestock cultivation of poultry, goats, cows and buffaloes that had been runs good enough. Development of livestock cultivation is done through guidance to the livestock farmers, and livestock breeds relief by local governments and the private party including the Ministry of Agriculture Republic of Indonesia. Development of livestock cultivation to meet the needs of the meat for the community and in order to support the national program the Ministry of Agriculture in the framework of national self-sufficiency in meat.

Aquaculture fishery development activities (fishponds) through the activity of making ponds and freshwater fish ponds by using mechanization by private parties with the community and assistance of fish seed. Aquaculture fishery development activities (fishponds) as an effort to utilize land that is not productive and increase incomes for the community. Aquaculture fishery activities development in Kolaka regency because natural conditions are potential for the development of freshwater aquaculture.

Priorities cooperation between the government of Kolaka regency with private party is environmental conservation activities. This activity is associated with nickel

mining business management activities by mining investors who have an impact on environmental degradation in region's of mining operations. The implementation of the cooperation is done through technical handlers environmental damage rehabilitation, reforestation and conservation of critical areas, and assistance of greening seedlings to community.

The development implementation of the priority sectors for 6 years of the implementation of Gerbangmastra program in Kolaka regency through local government partnership with the private party are shows a reality of significant achievement for the local government's efforts in solving the problems of development and to realize the community prosperous in Kolaka regency.

The involvement of the private party in the implementation of Gerbangmastra program in Kolaka regency through public-private partnerships have been able to fill the limitations of local government in terms of resources. This development partnership lasted for six years and has produced a variety of products services that benefit the community. Successful implementation of the development partnership in this Kolaka regency, shows that public-private partnership is the value and the new spirit in regional development, especially in the era of local autonomy.

The success of a development should be supported by capabilities and synergy of development actors including government, private, and community. Synergy among development actors in the implementation of regional development as one of the principles of good governance namely creates a cooperation between government, private sector and communities through partnerships.

Community participation in implementation of Gerbangmastra program is absolutely necessary, because the community who will ultimately implement the program. Community participation in implementation of Gerbangmastra program

realized through community involvement in contributing, involvement in organizing activities, and involvement in empowerment activities, have done good enough. Involvement in the contribution seen in the development meeting attendance, collect data and information, planning involvement and decision-making, donations (money, labor, materials), monitoring, maintenance and evaluation, all runs well.

Involvement in the organizing looks at the organizing activities of problems and needs of, the organizing of activities development, organizing of resource potential, and the development of community groups, all runs good enough. The Organizing of program activities was carried out by community citizen together with engage the forces that exist in the community, including community groups.

Community involvement in empowerment activities seen on involvement in the implementation of rural infrastructure development; development of facilities/infrastructure of education, development of facilities/health infrastructure, development of facilities/social infrastructure, productive economic development of community, the development of agricultural production, environmental conservation, development of aquaculture farms, and inland fishery cultivation development, all runs well enough.

Embodiment of socialization of development program, public-private partnerships, and community participation can encourage the effectivity of the implementation of Gerbangmastra program. The effectivity of the implementation of Gerbangmastra program is determined of accumulated of programs work productivity, the achievement of program objectives and community satisfaction with the achieved results. Level of achievement the effectivity of the implementation of Gerbangmastra program of the realization of the program work productivity achievement, the achievement of program objectives and the community satisfaction, showing good results. Gerbangmastra pro-

gram implementation since 2007 has produced a wide range of public services, namely: services infrastructure, education, health, social, economic of productive, agricultural production, environmental conservation, livestock cultivation business and the inland fishery cultivation businesses. Achievement of these results may provide benefits to changes in the joints of communities lives.

Path analysis

The analysis of the effect of public-private partnerships and community participation on successful of the implementation of Gerbangmastra program employees path analysis. The use of path analysis is to measure the direct effect and indirect effect inter the variables in the model.

Path analysis is done through phase of testing models to prove that the developed model is an appropriate model (fit). Model testing criteria is if the Chi-Square with an error rate (p) > 0.05, which indicates no effect or not real, meaning that the model fit because there is no difference between the hypothetical model with field data. Conversely, if the Chi-Square with an error rate (p) < 0.05 indicates an effect (real), meaning that the model does not fit because there is a difference between the hypothetical model with field data.

The test of the models using the program Amos 20.0 provides Chi-Square value of 3.229, and the probability value (p) of 0.07 > 0.05. These results show that there was no difference with field data. Index suitability of models such as CMIN/DF, and TLI, meet the criteria (Figure 2). This results explain that the model of developed has been according to specifications goodness of fit, namely the model that there is no difference between the hypothetical model with field data, so that it is feasible for further analysis.

Path coefficients of independent variables with the dependent variable indicates the occurrence of causality, whereas

of critical ratio shows significance impacts between the variables that affect to the variables that be affected. Causality relationship occurs significantly if the value of critical ratio (CR) is greater than the value of *t*-table of 1.645 at error rate (p) < 0.05.

The results of path analysis with AMOS program of version 20.0 (Table 1 and Table 2) shows the values of path coefficients and estimated direct effect, indirect effect and total effect between one of variables with other variables. Direct effect the variables between independent variables with the other independent variables and between the independent variables with the dependent variable.

The direct effect of the independent variables on the other independent variables looks at the direct effect of public-private partnerships (X_1) to the community participation (X_2) with value of path coefficient as big 0.747, significant at level error $0,01 < 0,05$ (Equation 1).

The direct effect of independent variables on the dependent variable, among other: public-private partnerships (X_1) directly effect to the successful of the implementation of Gerbangmastra program (Y) with value of path coefficient as big 0,345, significant at the level of error (p) $0,01 < 0,05$. While the community participation (X_2) directly effect to the successful of the implementation of Gerbangmastra program (Y) with value of path coefficient as big 0.409 and significant at the level of error (p) $0,01 < 0,05$ (Equation 2).

The use of path analysis that showed a direct effect between the independent variable with the other independent variables and between the independent variables with the dependent variable, path analysis also shows the indirect effect of independent variables on the dependent variable through the intermediate variable. Based on estimation the indirect effect (Table 2 and Figure 2) shows that the successful of the implementation of Gerbangmastra program (Y) indirectly affected by pub-

lic-private partnerships (X_1) through community participation (X_2) with value a total effect as big 0.650. Thus, any increase in implementation of public-private partnership are supported the community participation as big one unit, then the successful of the implementation of Gerbangmastra program will increase as big 0.650 unit.

Path diagram (Figure 2) also shows the contribution of public-private partnerships and community participation are simultaneously to the successful of the implementation of Gerbangmastra program (R^2) as big 50 %.

Based on the results of path coefficient analysis (Table 1) and estimation of the direct effect, indirect effect, and total effect among variables (Table 2), then the results of hypothesis testing using an error rate of 5% ($\alpha = 0.05$), is: (1) allegedly the public-private partnerships have effect to the successful of the implementation of Gerbangmastra program, empirically acceptable with value of direct effect coefficient as big 0.345 and significant at the level of error (p) $0,001 < 0,05$; (2) allegedly the public-private partnership in the implementation of Gerbangmastra program have effect to the community participation, empirically acceptable with value of direct effect coefficient as big 0.747 and significant at the level of error (p) $0,001 < 0,05$; (3) allegedly the community participation have effect to the successful of the implementation of Gerbangmastra program, empirically acceptable with value of direct effect coefficient as big 0.409 and significant at the level of error (p) $0,001 < 0,05$; (4) allegedly the public-private partnership and community participation are simultaneously have effect to the successful of the implementation of Gerbangmastra program, empirically acceptable with value of the total effect as big 0.650 and significant at the level of error (p) $0,001 < 0,05$.

The model of path diagram the direct and indirect effects between variables based on the results of model testing (Figure 2).

Table 1: Results of Path Coefficient Analysis between Variables

Variable that Affect	Variable that Affected	Path Coefficient	Critical Ratio
Public-private partnerships	Community participation	0,747	10,512 ***
	Successful of the implementation of Gerbangmastra program	0,345	4,814 ***
Community participation	Successful of the implementation of Gerbangmastra program	0,409	5,697 ***

Notes: *** indicates significant at 1% levels of significance

Table 2: Direct Effect, Indirect Effect, and Total Effects between Variables in the Model

Variables that Affect	Variable that Affected	Direct effect	Indirect effect	Total Effects
Public-private partnerships	Community participation	0,747	0,000	0,747
	Successful of the implementation of Gerbangmastra program	0,345	0,305	0,650
Community participation	Successful of the implementation of Gerbangmastra program	0,409	0,000	0,409

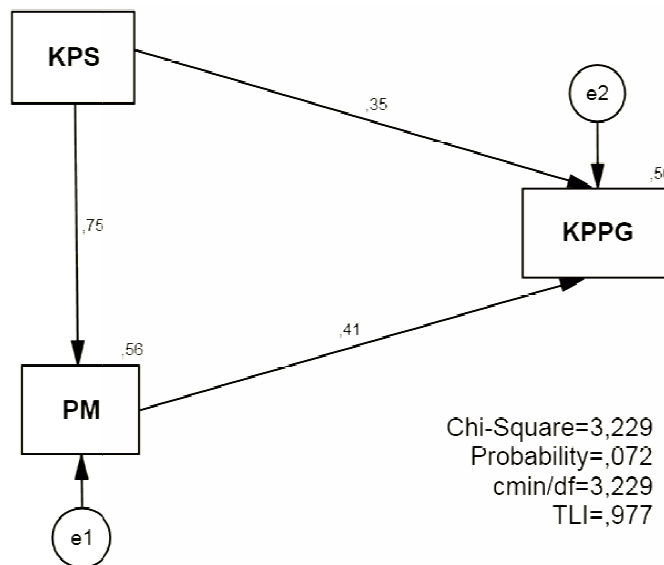

Notes: Public Private Partnership (KPS), Community Participation (PM), and Successful of the Implementation of Gerbangmastra Program (KPPG)

Figure 2: Diagram of Path the Direct Effect and Indirect Effect of Independent Variable to the Dependent Variable as Results of Model Testing

The results of path coefficient analysis and estimation of the direct effect between variables, showed that public-private partnerships directly affect to the community participation with value of path coefficient as big 0,747, significant at the level of error ($p < 0.05$). These results provide information that the implementation of local

government partnership with the private party in the implementation of Gerbangmastra programs which socialized to the community have effect to the community participation. The higher the implementation of public-private partnership in the implementation of Gerbangmastra program, then level of community participation in

supporting the implementation of Gerbangmastra program will be higher as well.

The research results are supported by opinion Armistead and Pettigrew (2004) that explain that public participation is very important to test the acceptability of a development partnership. Implementation of public private partnership in the implementation of development programs provide great benefits to community, because private organizations that have a production capability and high technical capabilities that are not owned by the government so that as to provide transformation of skills in development to the community. Because the public-private partnership has a correlation with community participation in the implementation of development.

Public-private partnership is a form of effort and cooperation between organizations in achieving common goals. In this partnership, each of the actors to contribute resources (financial, human resources, technical, and intangible such as inside information or political support) and participate in the decision-making process (World Bank, 1999).

Application orientation of public-private partnership in the implementation of development programs is to achieve of effectivity implementation of development especially to provide public services, then in its implementation involves development actors, namely government, private and community. The involvement of the private sector in the implementation of development programs with government and the community constitute a fundamental change in the development management that as if the community development work only the responsibility of government alone, but all stakeholders including the private sector have the same responsibility to the efforts of development and community empowerment that must be executed in harmony and balance.

Public-private partnership is one of the important elements that can encourage the achievement of successful of the im-

plementation of Gerbangmastra program. Local government partnership with private party in the implementation of the program is realized through private sector involvement in the implementation of operational cooperation in program activities and contribution of resource. Implementation of local government partnerships with private party are supported community participation can encourage the achievement of successful of the implementation of Gerbangmastra program. Successful of the implementation of Gerbangmastra program are identified of the achievement of public service products, achievement of program target and community satisfaction with the achieved results. Gerbangmastra program activities realized in the field of building of public infrastructure, education service, health service, social service, productive economic, agricultural, livestock farming, fishery, and environment.

The results of path coefficient analysis and estimation of the direct effect between variables, showed that public-private partnerships directly affect to the successful of the implementation of Gerbangmastra program with value of path coefficient as big 0.345, significant at the level of error (p) < 0,05. The higher the implementation of public-private partnership, then successful of the implementation of Gerbangmastra program be higher as well. This research results provide information that implementation of partnership between local government and private party can encourage the success of the implementation of Gerbangmastra program in Kolaka regency.

The research results are supported by the results of the study Gibson and Davis (2008) and Lee (2010), who explains that implementation of public-private partnerships can increase the effectivity of the implementation of cooperation program. The same opinion is explained by Kumorotomo (1999), that from management aspects, the benefits that can be achieved from the partnership is increased the effec-

tivity and efficiency of work. Symbiosis mutualism should be as the main basis of a cooperation shaped of partnership. The contribution of each party can be either capital or goods, experts or both at once. Its essence lies in the contributions together for a common goal.

Implementation of public-private partnerships can determine the success of the implementation of development programs. This is because the private sector has the facilities and resources that are rarely owned by the government, while the government has limitations in providing all the facilities and resources to implement development programs. Several previous studies indicate that implementation of public private partnerships can increase the success rate of development programs being run (Thuen and Laerum, 2005; Runde, 2006).

The results of this study are also supported by the results of the study Jamali (2004) who explains that combination the main characteristics of government and private party is able to provide a high level of success in the implementation of development programs. The Government characteristics of that tend rigid and enclosed are collaborate with private sector that tend flexible and open. The success of public-private partnership is determined by factors the role of government involvement, regulatory framework, resource dependency, commitment are symmetrical, similarity of purpose, communication, capabilities, and work culture.

The results study of Bagchi and Paik (2001) which identified a public-private partnership success depends on the partnership process running. The success of a development program run by the government and private partnerships determined since process the cooperation is established. Starting from determining of pre-conditions when cooperation was first performed. Then proceed with the development of partnerships by aligning the vision,

mission and goals, ends with the performance evaluation of the implemented program.

The results of path coefficient analysis and estimation of the direct effect between variables, showed that community participation directly affect to the successful of the implementation of Gerbangmastra program with value of path coefficient as big 0.409, significant at the level of error (p) < 0.05. The results of this study provide information that the public participation that realized through community involvement in contribution, community involvement in organizing, and involvement in empowerment, then can encourage the successful of the implementation of Gerbangmastra program. The higher the community participation, then successful of the implementation of Gerbangmastra program be higher as well. Achievement of successful of the implementation of Gerbangmastra program can be seen from the products of public service, achievement of the target programs, and community satisfaction with the results achieved from the implementation of Gerbangmastra program.

The results of this study are supported by the results of the study Soekamto, et al (2004) shows that community participation plays an important role in determining the successful achievement of program objectives in accordance with the aspirations and needs of the community itself. Community participation would happen if the implementers of development programs in the area are the people, organizations, or institutions that they believed his integrity, and if the program is to solve the problems they feel and can provide benefits to welfare of his life. Granting authority to the community will encourage community to mobilize all abilities and potential for the sake of the success of development programs.

These research results also supported by opinion Stiglitz (2002), that participation is required for full effectiveness

of a program or development project, transformation of development widely of community. Participation carries a variety of efforts or effort required for successful of development programs.

Active participation be expected to grow from local communities in implementing development programs. Community has a dual role, ie as the subject and object of development. Role as the subject of development, the community also determines and control the implementation process of a development program, and as an object of development, the community was subjected to various development programs. Therefore, the success or failure of development programs is actually more determined by community as well as the local governments as development facilitators. Community participation has a strategic role as a catalysator in the process of local development goals achievement.

The estimation results of the indirect effect and total effect (Table 2 and Figure 2), it is noted that the public-private partnership variables indirectly effect to the successful of the implementation of Gerbangmastra program through community participation variable with the value of the total effect as big 0.650. The implementation of public-private partnership of supported by community participation contributes to the successful of the implementation of Gerbangmastra program in Kolaka regency as big 50%.

These results prove that the implementation of public-private partnerships and community participation simultaneously can encourage the successful of the implementation of Gerbangmastra program in Kolaka regency.

The results provide a new perspective that to increase the achievement success of local development goals, especially in the era of local autonomy that demands of every area is more creative and innovative in formulating local development model based on existing authority, it is neces-

sary strengthen and intensify of the development communication to all components of existing development in the area, ie local government, private and community as a force that determines success in achievement development goals. One model of development that can be applied in the implementation of local development programs is the implementation of public-private partnerships, and community participation.

CONCLUSION

The successful of the implementation of Gerbangmastra program is determined by the implementation of public-private partnerships and community participation. The implementation of local government partnerships with the private sector in the implementation of Gerbangmastra program through operational cooperation and the contribution of resources runs good enough. Community participation in the implementation of Gerbangmastra program through community involvement in contributing, involvement in the organizing, and involvement in empowerment, are done well. The implementation of these two factors was able to increase the successful of the implementation of Gerbangmastra program. The successful of the implementation of Gerbangmastra program include the level of programs work productivity, and achievement of program target and community satisfaction with the results of development.

The results showed that the implementation of public-private partnerships that socialized to the community influences the community participation and successful of the implementation of Gerbangmastra program. The support of community participation through community involvement in contribution, community involvement in organizing, and community involvement in empowerment influences the achievement of the successful of the implementation of Gerbangmastra program. Similarly, the implementation of local government partner-

ship with the private sector supported by community participation effects the successful of the implementation of Gerbangmastra program in Kolaka regency with a total effects as big 0.650. The contributions of the implementation of public-private partnerships and community participation on the successful of the implementation of Gerbangmastra program in Kolaka regency is as big as 50 %.

The implementation of Gerbangmastra program in Kolaka regency which

lasted for six years has been good, as the impact of the implementation of local government partnership with the private party runs well, and the level of community participation was good.

The Government of Kolaka regency needs to conduct an evaluation and remedial measures through increasing development communication to further strengthen the implementation of partnerships with the private parties and maximizing community participation.

REFERENCES

- Armistead, C. and P. Pettigrew (2004), "Effective Partnerships: Building a Sub-Regional Network of Reflective Practitioners," *International Journal of Public Sector Management*, 17, 571-585.
- Bagchi, P.K. and S.K. Paik (2001), "The Role of Public-Private Partnership in Port Information Systems Development," *International Journal of Public Sector Management*, 14(6), 482-499.
- Gibson, H. and B. Davies (2008), "The Impact of Public Private Partnerships on Education: A Case Study of Sewell Group Plc. and Victoria Dock Primary School," *International Journal of Educational Management*, 22(1), 74-89.
- Jamali, D. (2004), "Success and Failure Mechanisms of Public Private Partnerships (PPPs) in Developing Countries: Insight from the Lebanese Context," *International Journal of Public Sector Management*, 17(4/5), 414-430.
- Kumorotomo, W. (1999), "Business Partnership as an Alternative in the Empowerment of the Public Sector in Region," *Sociopolitical Journal*, 3(1), 80-108.
- Lee, S. (2010), "Development of Public Private Partnership (PPP) Projects in the Chinese Water Sector," *Water Resource Management*, 24, 1925-1945.
- Runde, D. (2006), "How to Make Development Partnership Work," *OECD Observer*, 255, 29-31.
- Soekamto, H., R. Soeprapto and I. Noor (2004), "The Community Participation in Overcoming of Poverty," *Scientific Journal of Public Administration*, 4, 1-16.
- Stiglitz, J.E. (2002), "Participation and Development: Perspectives from the Comprehensive Development Paradigm," *Review of Development Economics*, 6(2), 163-182.
- Supriyadi (1999), "Effect of Implementation of Rural Development Programme to the Community Participation," *Journal of Management and Accounting*, 11(2), 152-165.
- Syahza, A. (2007), "Accelerating the Economic Empowerment of Rural Communities with Model Agroestate Based-Palm Oil," *Economic Journal*, 12(1), 126-139.

Thuen, F. and K.T. Laerum (2005), "A Public/Private Partnership in Offering Relation Education to the Norwegian Population," *Family Process*, 44(2),175-85.

World Bank (1999), *Working together for a Change: Government, Business and Civil Partnerships for Poverty Reduction in Latin America and the Caribbean*, EDI Learning Resources Series, The World Bank, Washington D.C.