

Design and Testing of Compressed Air Vehicle

Ankit D. Giradkar, Prof. Narendra K. Ade

Abstract— The production of domestic crude has been declining and the transport system has been increasing depend on imported crude oil to meet its needs. There is a growing concern that the world may run out of petroleum-based fuel resources. All these make it imperative that the search for alternative fuels is taken in right earnest. With the current fuel sources diminishing, we are looking for alternative ways to power our automobiles. With this goal in mind, companies are actively developing various new technologies from the perspective of achieving energy security and diversifying energy sources, which is necessitated by the dwindling supply of petroleum resources. The air engine works with air that is taken from the atmosphere and air pre-compressed in tanks. Air is compressed by the on-board compressor or at service station equipped with a high-pressure compressor. Air powered vehicles provides most comprehensive answer to today's urban pollution problems in simple economic and most inoffensive manner which makes car users to replace their present cars running on gasoline in the coming years as these cars are safe to use safe to users and are also environment friendly.

Index Terms—Alternative fuel, compressed air, chassis, eco-friendly, pneumatic wrench.

I. INTRODUCTION

The word pneumatic come from the Greek word Pnuma means air or wind. Tool and appliance driven by compressed air are known as pneumatic devices. Example of this devices are pneumatic vehicle, rock-drills, jack hammer, spray and airbrakes. Pneumatic vehicles also called air vehicles, use air to transport one location to another. Pneumatic vehicle systems do this by generating air pressure levels measuring either above or below the atmospheric pressure to move the materials through pipes or tubes or by converting the pressure into moment of mechanical device used as transport equipment in the vehicle system to the required destination. Storing compressed air into a small air tank and then using it for actuation of the vehicle. We design this vehicle to carry the weight of one person of 60 kg. The vehicles capacity is less due to small size of air tank. The air tank fitted on the vehicle is a compact unit. Tanks that will probably hold compressed air to about 14 bar pressures. Its accelerator operates a valve on its tank that allows air to be releases into the hoses and then into the motor, where the pressure of the airs expansion will push against the vanes and turn the rotor. This will produce enough power for speeds of about 15-20

Ankit D. Giradkar, Mechanical Engineering, Rajiv Gandhi College of Engineering Research and Technology, Chandrapur, India

Prof. Narendra K. Ade, Mechanical Engineering, Rajiv Gandhi College of Engineering Research and Technology, Chandrapur, India

km/h. This design of the vehicle is used to minimize the pollution to the environment and to overcome the rising prices of petrol and diesel as it is the most important concept of the common man's life. This principle can mainly use for transportation of material and parts in the industries. The continuous hikes of fossil fuel rise at the rate around 20% -30% every year are making the situation miserable. Extrapolation shows that at this rate, by 2010-2012, fossil fuel price may double as what they were in 2005, and by 2030-2040, it may touch 1000 RS/lit. A time may come when the person will not be able to purchase fuel to run the motor bikes. This is not due to the high demand for vehicles or it is increasing number worldwide but also due to cost of fossil fuel high as 80% of the available fossil fuel presently being consumed in transport. Thus, it is imperative explore the possibility of alternatives to fossil fuel to make the environment free from emission and keep the present and future generation healthy.

II. MODEL

Following pictures shows the chassis of the CAV model.

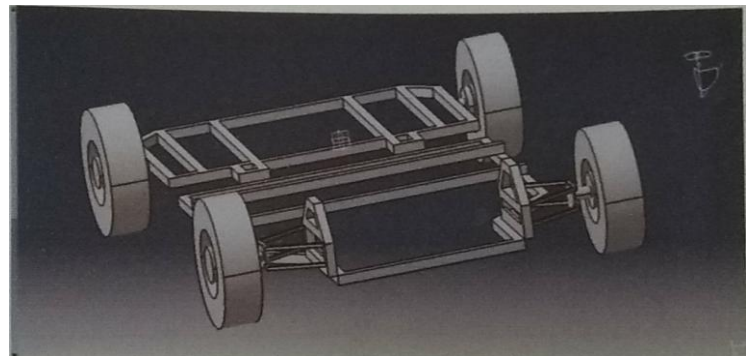

Figure 1- 3D Model of Frame

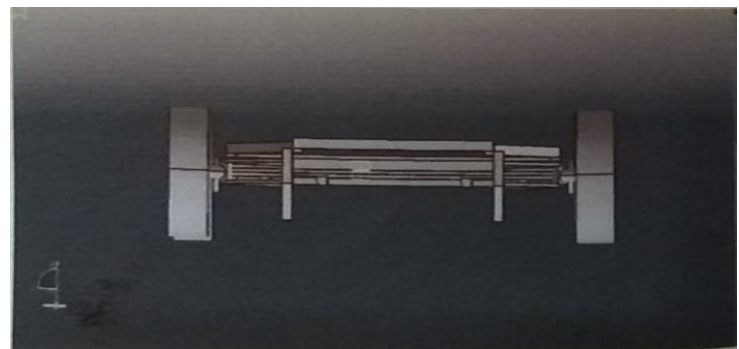

Figure 2- Front View

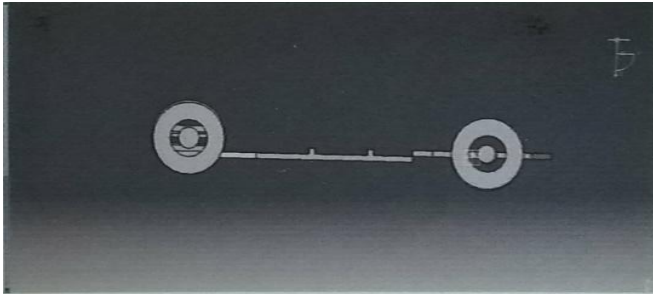

Figure 3- Side View

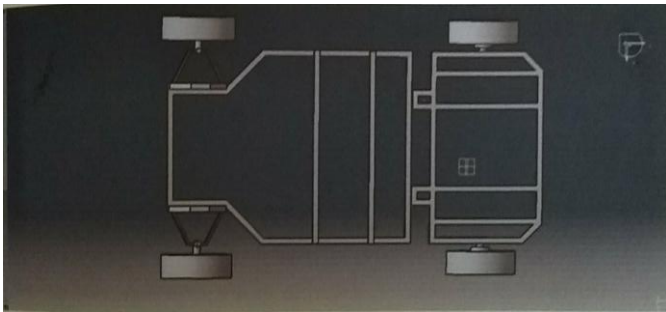

Figure 4- Top View

III. MAIN PARTS

A. PNEUMATIC WRENCH

A pneumatic wrench or compressed air engine is a type of motor which does mechanical work by expanding compressed air [10]. Pneumatic wrenches generally, convert the compressed air to mechanical work through either linear or rotary motion. Linear motion can come from either a diaphragm or piston actuator, while rotary motion is supplied by either a vane type air motor or piston air motor. Pneumatic motors have existed in many forms over the past two centuries, ranging in size from hand held turbines to engines of up to several kilo Watts. Some types rely on pistons and cylinders, others use turbines. Rotary Vane Air motors feature durable construction with precision heavy-duty bearings throughout, and multiple blade rotors for smooth power. There is a wide range of speeds and torques as well as a choice of foot, face, or flange mounting. These wrenches require airline lubrication for long, trouble-free service. Mount the lubricator as close to the motor as possible. These motors perform satisfactorily in high temperature areas up to 200°F (93° C).



Figure 5- Pneumatic Wrench

Idle speed	6300 rpm
When connected to wheel	2330 rpm
On load speed	425 rpm
Weight	6 Kgs
Torque	1000 N-m approx..
Air inlet (PT)	1/2 inch
Air Hose (ID)	3/4 inch

Table 1: - specifications of pneumatic wrench

B. AIR TANK

SPECIFICATION:

1. Tank capacity – 130 litres
2. Tank size – length- 1070 mm (42 inch)
Diameter- 356 mm (14 inch)
3. Time to fill – 4 mins
4. Cylinder storing pressure – 11.03 bar
5. Working pressure – 6.2 bar



Figure 6- Air Tank

IV. WORKING

A pneumatic wrench uses air to produce rotational motion to a shaft. The rotating element is a slotted rotor which is mounted on a drive shaft. Each slot of the rotor is fitted with a freely sliding rectangular vane. The vanes are extended to the housing walls using springs, cam action, or air pressure, depending on the motor design. Air is pumped through the motor input which pushes on the vanes creating the rotational motion of the central shaft. Rotation speeds can vary between 100 and 25000 rpm depending on several factors which including the amount of air pressure at the motor inlet and the diameter of the housing. Stored energy in the form of compressed air, nitrogen or natural gas enters the sealed pneumatic wrench chamber and exerts pressure against the vanes of rotor. Much like a windmill, this causes the rotor to turn at high speed.

V. PARTICULARS OF COMPONENTS USED IN THIS VEHICLE

- 6mm, 8mm, 10mm bolts for brake, seat and angular fixtures.
- Grinding and metal cutting for minor parts are done using a portable grinding machine.
- 6mm drills with a hand drill, 8mm and 10mm drills with an upright drilling machine.

- Wheel rim dia.: 280mm.
- Wheel dia.: 380mm.
- Wheel width: 75mm.
- Front track length: 1070mm.
- Ground clearance: 280mm.
- Tank thickness: 3mm.
- Bearing OD: 35mm.
- Bearing ID: 15mm.
- Bearing thickness: 10mm
- Over-all length: 2340mm.
- Over-all height: 1060mm.
- Over-all width: 1290mm

VI. CALCULATIONS

A. Calculation of Design power

Rated power

$$P_r = \rho g Q H$$

Where, ρ → density of air

g → Acceleration due to gravity

Q → Discharge of air gun

H → Head of air column

$$W = \rho g = 1.2 \text{ kg/m}^3$$

$$Q = 12 \text{ CFM (Cubic feet/minute)}$$

$$H = 5160 \text{ m}$$

$$\therefore P_r = 1.2 \times 0.3 / 60 \times 5160$$

$$= 30.96 \text{ kg.m/sec}$$

$$= 303.717 \text{ N-m/sec or Watt}$$

$$P_r \approx \mathbf{300 \text{ Watt}}$$

∴ Design power of Air gun,

$$K_1 = 2 \text{ (load factor)}$$

$$P_d = P_r \times K_1$$

$$= 300 \times 2$$

$$P_d = \mathbf{600 \text{ watts}}$$

B. Speed of Air gun

Idle speed – 6300 rpm

Considering reduction of (2.7) i.e. V.R = 2.7 when connected to wheel

$$\therefore N = 2333 \text{ rpm}$$

Again, considering load,

$$N = 424.18 \text{ rpm}$$

$$N \approx \mathbf{425 \text{ rpm}}$$

C. Speed of vehicle

$$\text{Radius of wheel} = 190 \text{ mm}$$

$$\therefore \text{Diameter of wheel} = 380 \text{ mm} = 38 \text{ cm}$$

$$\therefore \text{Circumference, } C = \pi d = \pi \times 38 = 119.38 \text{ cm} \\ \approx 120 \text{ cm}$$

i.e. one revolution of car = circumference of wheel

$$\therefore \text{For 425 revolutions of wheel per minute,}$$

$$= 425 \times 119.38$$

$$= 50736.5 \text{ cm/min}$$

$$\text{i.e. } 50736.5 \text{ cm/min} = 0.50736 \text{ km/min}$$

$$= 30.44 \text{ km/hr}$$

$$\approx \mathbf{31 \text{ km/hr}}$$

VII. PERFORMANCE AND TESTING

After design and fabrication of CAV the testing is carried out. For this purpose, the required data is collected from the actual vehicle as follows.

$$\text{Weight of vehicle} = 150 \text{ kg}$$

$$\text{Weight of the driver} = 60 \text{ kg}$$

$$\text{Total weight} = 210 \text{ kg}$$

A. CALCULATION OF ACTUAL AVERAGE POWER DEVELOPED BY CAV

Here, the actual power required to drive our vehicle. CAV covers 130m distance in 30 sec.

$$\therefore \text{Avg. Velocity of vehicle} = 130/30$$

$$= 4.33 \text{ m/sec}$$

$$\text{Avg. acceleration} = 4.33/30$$

$$= 0.144 \text{ m/sec}^2$$

∴ Force required to overcome the inertia of vehicle

$$F = ma$$

$$= 210 \times 0.144$$

$$= 30.24 \text{ N}$$

Work Done, $W = F \times D$

$$= 30.24 \times 130$$

$$= 3931.2 \text{ Nm}$$

Avg. power = W/T

$$= 131.04 \text{ Nm/s or Watts}$$

$$= 131 \text{ W (approx.)}$$

Amount of electricity required to fill the tank of CAV,

$$\text{Reading of energy meter} = 94 \text{ rev}$$

$$\text{Time req. to fill the tank} = 300 \text{ sec}$$

$$\text{Pressure in tank} = 14 \text{ bar}$$

$$\text{Energy consumption in Kw is} = 94/300$$

$$= 0.313 \text{ Kw hr}$$

$$= 313 \text{ Watts}$$

The actual consumption is 313 Watts.

Overall efficiency of vehicle considering that the tank is filled by electrically driven compressor.

$$\eta = (\text{Power at rear axle in watt}) / (\text{Power req. to fill the tank})$$

$$= 131/313$$

$$= 41.85 \%$$

Estimation of Actual power delivered by air motor

$$\text{Avg. air motor power} = 131 / \eta_{\text{mech}}$$

$$(\eta_{\text{mech}} = 0.85 \times 0.85 \times 0.75)$$

$$\therefore \text{Avg. air motor power} = 131 / (0.85 \times 0.85 \times 0.75)$$

$$= 241.75 \text{ watts}$$

As per specification of air motor the power calculated is 241.75 watts which is less than rated power of air motor.

As per the power of 241.75 watts as per assumed transmission efficiencies. Thus, it seems that the losses in transmission are more than expected.

Hence it is advisable to re-think on the transmission side of CAV and may be redesigned in future.

The actual efficiency of transmission system is found to be

$$= \text{avg. power} / \text{actual power}$$

$$= 241.75/600$$

$$= 40.29 \%$$

The various losses are due to not considering the following factors.

- Air resistance.
- Gradient
- Rolling resistance

- Type of road surface
- Some unexpected losses in transmission
- May be due to misalignments in transmission system

These all factors might have contributed to this loss.

VIII. APPLICATIONS

1. Family Cars
2. Vans
3. Taxies
4. Pick-ups
5. Mini-Cats

IX. ADVANTAGES

1. Major advantages of using compressed engine is that a pure compressed air vehicle produces no pollution at the tailpipe.
2. Use of renewable fuel.
3. Air, on its own, is non-flammable.
4. Low manufacture and maintenance costs as well as easy maintenance.
5. The price of filling air powered vehicles is significantly cheaper than petrol, diesel or biofuel. If electricity is cheap, then compressing air will also be relatively cheap.

X. FUTURE SCOPE

The system eliminates the need for fuel, making the environment pollution-free. The compressed air drives the air motor, which turn the vehicle's wheels. Once compressed, the air is stored in a tank. The compressed air is used when the car needs a lot of energy, such as for starting up and acceleration.

In future, we can use air vehicle with some modifications:

1. After increasing tank capacity.
 2. By using air engine and suitable pneumatic wrench.
 3. By using different composite materials of high strength, weight of the parts like chassis, storage tank etc. reduces which results in low weight of the vehicle.
 4. By providing different gear ratios in gear box.
 5. By reducing losses of air flow through nozzles, pipes, etc.
- With above some modifications it is possible to increase the performance and distance achieved by the vehicle.

XI. CONCLUSION

From the observation, it can be concluded that compressed air power car can prove to the future vehicles. This is a revolutionary engine design which is ecofriendly, pollution free, but also very economical. This redresses both the problems of fuel crises and pollution. These are zero emission vehicle. To sum it up, they are non-expensive cars that do not pollute and are easy to get around in cities. It's important to remember that while vehicles running on only compressed air might seem like a distant dream, but they still have public interest due to their environmental friendly nature. Compressed air for vehicle propulsion is already being explored and now air powered vehicles are being developed as a more fuel-efficient means of transportation. This paper explores the effective application of pneumatic power. Pneumatic vehicle will replace the battery-operated vehicles used in industries. Pneumatic powered vehicle requires very less time for refueling as compared to battery

operated vehicle. The performance can be improved by increasing inlet pressure, reducing the vehicle weight etc. However excessive research is needed to completely prove the technology for both its commercial and technical viability.

REFERENCE

- [1] "DESIGN AND DEVELOPMENT OF COMPRESSED AIR CAR"; Project Report, Rajiv Gandhi College of Engineering, Research and Technology; Year- 2010-11
- [2] Anirudh Addla & Srinivasu Gangada, "Fabrication & Testing of Compressed Air Car Viswanadha Institute of Technology and Manegment", Globle journals Inc (USA), 2013
- [3] Bilal Abdullah Baig, Hakimuddin Hussain," Design and Fabrication of compressed Air Powered Car", International journal on Resent and Innovation Trends in Computing & Communication volume: 3
- [4] Karan R. Jagtap, Swapnil A. Patil, Shripad P. Raje, Sachin R. Pawar, Prof. Vinay J. Raje; "Design and Manufacturing of Pneumatic Vehicle for Industrial Purpose"; Dept. of Mechanical Egg; JSPM NTC, Narhe Pune, India; Year-2017
- [5] www.theaircar.com
- [6] www.wikipedia.com
- [7] www.engineeringtoolbox.com

Ankit D. Giradkar, Mechanical Engineering, Rajiv Gandhi College of Engineering Research and Technology, Chandrapur, India

Prof. Narendra K. Ade, Mechanical Engineering, Rajiv Gandhi College of Engineering Research and Technology, Chandrapur, India