

Geographical Information System (GIS) Based Electrical Energy Theft Detector Device

Mathew Chukwu Udo, Joseph Elijah, Amit Mishra, Idris Rabi, Fairwater S.S

Abstract— The paper is a response to the urgency needed to checkmate commercial losses in electrical distribution system in Nigeria. Root causes of electrical commercial losses were investigated by field work carried out on sampled customers of 33kV Keteregi feeder in Minna, Niger State of Nigeria. Questioners were administered by interviewing customers. GIS coordinates of customers' building were carefully taken using GPS receiver, and other information such as customer's name, building type and meter inspection were collated. The results of the field survey revealed that most electrical energy theft is by meter bypass. A further step was taken by designing and simulating theft detector circuitry using Proteus electrical design software. The design was implemented using microcontroller for multifunction. Microcontroller checks for difference in the input and output to a prototype prepaid meter. The difference in the input and output voltage of the prototype prepaid meter indicates meter by-pass which means electrical energy theft detected. The data such as customer's names, physical address and GIS coordinates were encoded in the memory of the microcontroller. The design implementation was tested by bypassing a prototype prepaid meter. The result obtained from bypass was noticed as Short Message Sent (SMS) through the Global System of Mobile Telephoning (GSM) interfacing the microcontroller. This shows that the GIS based electrical theft detector device designed and implemented was able to detect electrical energy loss through meter bypass.

Index Terms- Electricity, GIS, theft,

I. INTRODUCTION

Reference [1] described Power System as a network that provides regions, industries and homes with electrical energy. Electricity generation, transmission and distribution are three stages of delivering electricity to consumers [1]. This power system is known as the grid and can be broadly divided into the generators that supply the power, the transmission system that carries the power from the generating centres to the load centres and the distribution system that feeds the power to nearby homes and industries. The distribution system is a part of power systems which is dedicated to delivering electrical energy to the end user. The planning and the design of electrical supply system are everyday task for engineers in the electric utilities companies. The goal of power distribution planning is to satisfy the growing and changing load demand within operational constraints and with minimal costs [2]. It is necessary for Power Distribution Company to update their customers' information that corresponds to their electrical attributes. The database contains useful information that

shows linkages with the distribution transformers, feeder and substation. It is also important to design a system that monitor the accuracy of consumption at the customer end. The design of smart system improves system reliability, hence encourages investments to the industry.

Current electrical distribution system in Nigeria requires intensive approach in order to deliver quality energy to the customer. Energy losses are the major factors hindering the delivering of electrical energy. These losses are categorized as technical and commercial losses. High technical distribution losses in the system are primarily due to inadequate investments over the years for system improvement works, which has resulted in unplanned extensions of the distribution lines, overloading of the system elements like transformers and conductors, and lack of adequate reactive power support [3]. The commercial losses are mainly due to low metering efficiency, power theft, pilferages under billing and sharp practices of distribution staffs.

Electrical Distribution system provides needed fund for sustenance and maintenance of generation, transmission and distribution therefore, revenue loss in distribution may lead to severe revenue loss. Design of an effective system that would check theft within the customer's metering system is of paramount importance. The GIS coordinates of customers' buildings obtained during the field work is used to encode memory of consumption meter in order to identify customers and locations where electrical theft occurred. The GIS information stored in the individual consumption meter are in the form of eastern (x), northern (y) coordinates, customers name and physical address. The information are retrieved from the meter's memory in the case of electrical theft and send it to the management of the distribution company for an action to be taken on the customer involved in electricity theft.

The planning process comprises several phases, and one of the most important is the optimization of electric distribution network. However, for the purpose of this research, optimization of the feeders is not considered because the actual load demanded cannot be ascertained as a result inefficient metering of which much effort would be made for improvement. Planning of electricity utility involves knowing the consumers and their locations but this cannot be completely achieved without the knowledge of geographically referenced data. In this process, it is important to have accurate data that would yield relevant information on the electrical distribution system and its assets, and possibly to have data support from other utilities. Electrical power distribution is very complex and for this reason Geographical

Engineer Mathew Chkwu Udo Huawei Technologies Co., Nig LTD.
Joseph Elijah, Department of Mathematics/Computer Science, IBB
University, Lapai, Nigeria.

Dr. Amit Mishra (PhD), Department of Mathematics/Computer
Science, IBB University, Lapai, Nigeria.



Information System (GIS) is applied by the use of related software such as Arc GIS 10.1 that can be used to create database of customers and assets of the distribution. Geographical Information Systems (GIS) technology facilitates planning of an electrical distribution network which sometimes is difficult to access for surveying like remote hilly areas. Computerization and development of various geographical information systems need new horizons for all decision-making processes as well as for manipulation and dissemination of information. The aim of this paper is to detect electricity theft through meter by-pass at consumers point and alert distribution authority of the location where theft occurred, and to use Geographical Information System (GIS) survey and data processing for database creation, which would in turn help in detecting electricity theft in a location. Finally, to design and simulate circuitry for detecting electricity theft at consumers point.

II. LITERATURE REVIEW

Electrical distribution improvement has many approaches ranging from feeder optimization, phase balancing and costing model for distribution planning. All these are ideas and efforts by many scholars in the field of electrical engineering to improve distribution. In Nigeria, the power distribution has constituted seventy per cent of electrical utility problem [4]. Due to inadequacies in planning and use of wrong solution for an identified problem, it is obvious to note that the major problem of electricity utility comes from distribution of bulk power that have been transmitted over a long distance and the reason for this is that distribution demands are not known and well managed. Against the back drop that consumers of electricity are not identified based on their location, it is impossible to estimate the accurate demand of electricity for customers in such area. Another major problem is identified as commercial losses that reduces revenue, hence discourages investment into the system [5]. The use of estimated load has also reduced the system reliability. This is a problem that cannot be solved overnight; however, with the right approach, solution is certain. Geographical Information System (GIS) can provide the solution in the management of utility by way of detecting commercial loss which is a function of electrical theft.

A. Distribution Challenges

The energy obtained in the electric generation process must be transported to the end user by conductors without large resistive power losses in the distribution process. Distribution system is associated with various challenges of which if not well managed may led to inefficiency, for example, difficulties of managing loads at injection substations is mainly as a result of overloaded feeder which tripped at will. Feeder tripping on overload is an indication that actual load designed for it is exceeded, hence unreliability of the system. Studies have also showed that the major problem facing electrical utility in Nigeria is that of distribution and its facilities [6]. These problems are mainly in the management of distribution in which the actual consumption rates are not known. In comparison, it is easier to manage generation and transmission, but the main problem has been on inadequate and neglect of distribution facilities to guarantee reliability and accessibility of power supply to the consumers [7].

Reference [8] stated that the distribution system begins either at the substation where power is delivered by overhead transmission lines and stepped down by transformers. Reference [4] noted that while telecommunication market in Nigeria has recorded advancement and stability, the electricity market in Nigeria is facing mixed challenges ranging from slow growth in generation capacity, market deregulation process interference by Government, electrical transmission lines and distribution equipment vandalism, poor maintenance of existing electrical facilities and corruption. These are indications necessitating the application of modern technology because greater percentage of these problems is caused by the inability of utility manager to identify their facilities and customers. Identification of the customer and facilities would encourage a better planning hence enhance quality service delivery and easy management of which is one of the essentials of Geographical Information System (GIS).

III. HIGHLIGHT OF GEOGRAPHIC INFORMATION SYSTEMS

Geographic Information System (GIS) come in all shapes and sizes. Some are project- specific and support a single initiative for a fixed period of time [9]. GIS is mainly used for spatial analysis which aids presentation of data in cartographic forms. Database is capable of relating large amount of information as well as spatial analysis in a system. This work concentrate on geo-database solution and it emphasise the ability of geographical information system (GIS) to combine information that is originally maintained in different environment. Modelling of electrical distribution system is also in the scope of Geographical Information System. The system is designed and implemented which is maintained by users in different locations. All information contained in the design can be accessed with proper coordinate. The information could be in the form of imagery, video, spatial and database) which can establish link through map graphic and finally traced back to the location on the earth surface. GIS is a digital tool for capturing, storing, viewing, integrating, analyzing, controlling and displaying of geographical information on a computer system. The most conspicuous attribute of GIS is its ability to display information in picture form as a picture is used for better explanations. Environmental Systems Research Institute (ESRI), as the world leader in Geographic Information System (GIS) technology, and described Geographic Information System (GIS) as an organisation of computer hardware, Software, and geographic data that user interact with to combine, analyze, and visualize data; identify relationships, patterns, and trends; and identify solutions to problems.

IV. RELEVANCE OF GIS IN ELECTRICAL DISTRIBUTION

The use of Geographical Information System (GIS) technology in Electrical utility is emerging as an efficient planning and decision making tool. Geographical Information System (GIS) for database integration operations such as query and statistical analysis make it more advantageous when compared with other information systems. Visualization and geographic analysis makes Geographical Information System (GIS) a unique tool in electrical engineering application [10]. The advantages are noted as it is

possible to manipulate and carry out tasks that are vital in management of electricity for proper and efficient results. Reference [11] noted that electric utilities are realising the benefits of Geographical Information System (GIS) technology in the management of facilities for engineering, construction operations, and maintenance and services purposes. The idea of Geographical Information System (GIS) application in utility management such as Electricity is becoming a new technology used in many advanced countries of the Globe. In India, UK, USA and many other advanced countries, Geographical Information System (GIS) application in utility management is of the Universal Transverse Mercator (UTM) priority. Reference [11] acknowledged the complexity of electrical distribution system and necessity of actuating up-to-date information of the network assets, as a reasonable intention for introducing new method of information technology. Customer's demands over time, pressurises various kinds of technologies and skills to be banked upon by utility companies in order to improve the level of services. For this reason, Geographical Information System (GIS) has become in effect, one of the tools for generating, arranging and managing geospatial information.

Reference [12] shows a transition in recent years from the ways in which utility companies which have previously been engaging Geographical Information System (GIS) as departmental solution to an enterprise solution where data is accessible by thousands of people. The study clearly indicates the capability of spatially enabled information system in the management of electricity distribution network. Spatial and attribute data of power distribution network of any part of the selected areas of interest of this study, which are presently acquired, processed, managed, stored and presented in analogue form, can be digitalised. Reference [13] noted that Geospatial Information (GI) is very essential to economic planning and national development.

V. GIS IN INFORMATION PROCESSING

Geographical Information System (GIS) is a powerful tool which enables information management by way of data acquisition, processing, storage and retrieved for specific utilization. Reference [11] defined Geographical Information System (GIS) as integrated sets of hardware, software, databases and processes designed to gather, pre-process, analyse and visualise data susceptible to be spatially located and related. Reference [10] noted that Geographical Information System (GIS) can effectively manage information on the distribution of electricity to customers and is describing the attributes of each customer such as location and electricity use.

The advantages of Geographical Information System (GIS) application to distribution network cannot be over emphasised. However good knowledge of physical assets of the utility management is necessary to make strategic and operation decisions [14]. Traditionally power distribution management required record keeping, Geographical Information System (GIS) technique implore database creation which is regularly updated. A good Geographical Information System (GIS) program is able to process geographic data from a variety of sources and integrate it into a map project.

Many countries have an abundance of geographic data for analysis, and governments often make Geographical

Information System (GIS) datasets publicly available. Map file databases often come included with GIS packages; others can be obtained from both commercial vendors and government agencies. Some data is gathered in the field by global positioning units that attach a location coordinate (latitude and longitude) to a feature such as a pump station. GIS maps are interactive, on the computer screen; map users can scan, adjust and manipulate it to fit in to the purpose. Functional attributes are attached to the map which enable user identifies feature such as gas pipe line, hospital, and other features embedded with physical addresses for easy recognition.

VI. RESEARCH APPROACH

The methods used for achieving the results of this work are GIS implementation, Circuit design, simulation and construction of theft detector device. GIS implementation involves data classification, sourcing, processing and presentation. Circuit design involves the use of electrical design software to check possibility of having a functional circuit implementation. Circuit simulation helps to describe the circuit upon implementation, while circuit construction is the actual implementation of the designed circuit.

VII. GIS IMPLEMENTATION

The first step taken was the GIS data collection and processing. Data collection is explained using the block diagram illustrated in Figure 1.

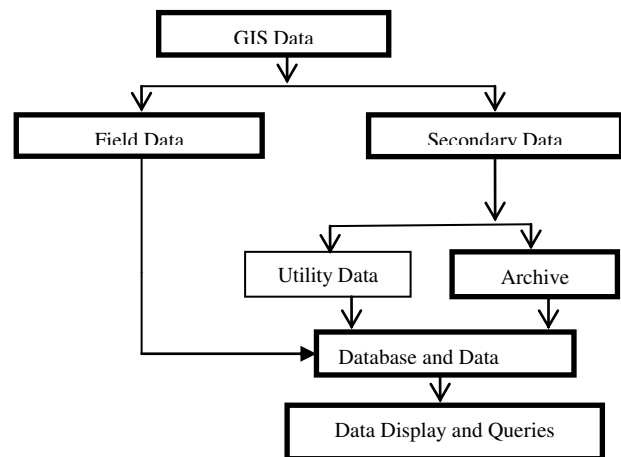

Figure 1 Block diagram of GIS data processing

VIII. DATA TYPE, SOURCES AND COLLECTION

The data obtained from field are of two kinds; primary and secondary data. The primary data are those acquired during the field survey of sampled distribution customers in Minna Niger State.

The GIS primary data were collected with the help of GPS receiver tool by name Germin Legend Etrex. This tool has the ability to receive GIS coordinates accurately from the orbital satellite. These include GPS coordinates of consumers' latitude and longitude (x and y), physical address of buildings and metering information of customer.

The secondary data were sourced from AEDC Archive in Minna office and mapping agencies. These include data from online surveys, selected reviewed literatures and also archive data from the Abuja Electricity Distribution Company

(AEDC) Minna Business Unit. The base map of the area of study was subscribed and downloaded from Google Earth website and the distribution data containing information such as address of customers and facilities were also obtained from AEDC archive.

Ikonos Satellite Imagery of 0.6mimage resolution got from authorised reseller and Google Earth Imagery captured through online from Google Earth software were secondary data used. Global Positioning System (GPS) receiver and Camera data are tools for primary data for acquiring coordinates and pictures respectively while writing materials were used for recording addresses and other observation. The GPS receivers were powered on to receive satellite signal for positioning-fixing at various location whose spatial information are required such as customer houses. The displayed coordinates were recorded when the GPS mode changes to static mode and snapshot of important scene were taken. The field survey was accompanied with questionnaires which were offered to respondents to ascertain their names, phone numbers and physical addresses. Physical inspections were also carried out in order identified customer involved in meter by-pass.

ID	Shape	Path	Name	POINT_X	POINT_Y	POINT_Z	customers	Address_1	Suspected	Building_T	Meter_Status
1	Point ZM	2 C:\Users\GPSA-00002\pg...	8.5301	9.58898	229	KONIA SCHOOL	KPAKINGU	NO	UPSTAR	DK	
1	Point ZM	3 C:\Users\GPSA-00003\pg...	8.53075	9.58924	0	CENTRE FOR ISLAMIC	KPAKINGU	NO	BUNGALOV	DK	
2	Point ZM	4 C:\Users\GPSA-00004\pg...	8.53079	9.58906	206.5	MAL WISA DALURIA	KPAKINGU	YES	BUNGALOV	NO METER	
3	Point ZM	6 C:\Users\GPSA-00006\pg...	8.531	9.58919	210.8	BSAHM SAM	KPAKINGU	YES	BUNGALOV	NO METER	
4	Point ZM	7 C:\Users\GPSA-00007\pg...	8.53091	9.58942	211.9	KPAKINGU POLICE STA	KPAKINGU	NO	BUNGALOV	NO METER	
5	Point ZM	8 C:\Users\GPSA-00008\pg...	8.53122	9.58928	213.8	KPAKINGU GARAGE	KPAKINGU	YES	SINGLE SHOPS	NO METER	
6	Point ZM	1 C:\Users\GPSA-00014\pg...	8.53122	9.58919	213.7	PHON BUILDING	KPAKINGU JUNCTION	NO	UPSTAR	DK	
7	Point ZM	1 C:\Users\GPSA-00014\pg...	8.51263	9.58919	214.7	ADAMU NEAR ISLAMIC	NEEDO AREA	YES	BUNGALOV	NO METER	
8	Point ZM	1 C:\Users\GPSA-00015\pg...	8.50424	9.57981	224.7	TALBA ESTATE	BIDA ROAD	NO	FLATS	DK	
9	Point ZM	1 C:\Users\GPSA-00016\pg...	8.49891	9.57433	223.5	NEEDO	NEEDO AVENUE	NO	ORGANISATION	DK	
10	Point ZM	1 C:\Users\GPSA-00018\pg...	8.49526	9.58985	224.9	HASSAN	NEAR NEEDO	YES	LOCAL	NO METER	
11	Point ZM	1 C:\Users\GPSA-00019\pg...	8.49526	9.58982	223.3	UMARU YAVIA	GEBAN WANGORO	YES	WOOD HOUSE	NO METER	
12	Point ZM	2 C:\Users\GPSA-00020\pg...	8.49538	9.58933	231.1	ADAMU USEN	GEBAN WANGORO	YES	LOCAL HOUSE	NO METER	
13	Point ZM	2 C:\Users\GPSA-00025\pg...	8.49538	9.58928	236.6	PUBLIC SCHOOL	GEBAN WANGORO	YES	BUNGALOV	NO METER	
14	Point ZM	2 C:\Users\GPSA-00026\pg...	8.49314	9.58928	237.9	HEALTH CENTRE	GEBAN WANGORO	NO	BUNGALOV	NO METER	
15	Point ZM	2 C:\Users\GPSA-00027\pg...	8.49314	9.58934	235.2	BULLI SHOP	GEBAN WANGORO	YES	SINGLE SHOPS	NO METER	
16	Point ZM	3 C:\Users\GPSA-00031\pg...	8.51263	9.58987	0	ICC BUILDING	BIDA ROAD	NO	BUNGALOV	DK	
17	Point ZM	3 C:\Users\GPSA-00032\pg...	8.50494	9.58922	218.7	NAFAT	BIDA ROAD	NO	RELIGIOUS	DK	
18	Point ZM	3 C:\Users\GPSA-00033\pg...	8.50728	9.58932	231.2	SANIDA WOOD SCHOOL	BIDA ROAD	NO	UPSTAR	DK	
19	Point ZM	3 C:\Users\GPSA-00036\pg...	8.52942	9.58974	238.5	FLAGS	BIDA ROAD	NO	UPSTAR	DK	

Figure 2: Sampled data base of customers with geographical coordinates in green

IX. DESIGN AND SIMULATION OF THEFT DETECTOR DEVICE

The design and simulation of theft detector device is a step further taken in achieving the results of this work. The block diagrams in Figure 3 and Figure 4 are used for expressing the circuitry of the theft detector circuit.

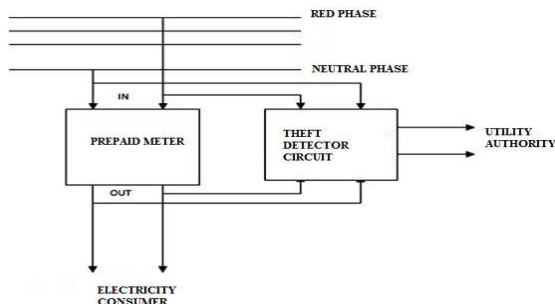

Figure 3: Block diagram of the overall system

The block diagram comprises of two segments; the first segment is the prepaid metering unit and the second is the theft detector unit. For the scope of this paper, the detector

circuit is considered and is further subdivided in the block diagram of Figure 4.

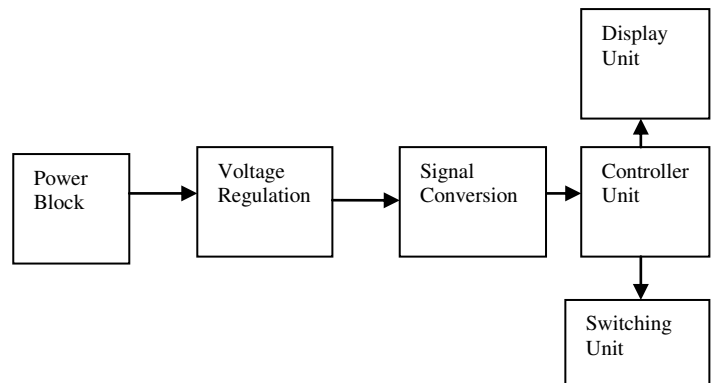

Figure 4: Block diagram of theft detector circuitry

The circuitry for the block diagram in Figure 4 has the following components: Relay, Microcontroller; AT89c52, ADC0804, Voltage Regulator; 7805, A Card Reader, 9V power transformer, Bridge Rectifier, PNP transistor, Capacitor, Voltage transformer and resistors.

For the design of theft detector circuit, the library tools of an electrical design software Proteus is used to pick the listed component. Placement of the component was done using drag and drop tool. Connection of component was done using drag and drop tools as follows;

The AT89c52 controller pin 1port (0-7) latches the pin 11 to 18 of the ADC0804, the Analogue to Digital Converter (ADC) server as a memory to the controller without any interfacing logics. The Liquid Crystal Display (LCD) pot 0 to 7 are connected to the controller pot 0, pin 1 to 7. The 9V transformer is connected to a bridge rectifier and a filtering capacitor is connected the bridge rectifier and voltage regulator 7805. The voltage regulator is connected to the following; ADC through pin 20, the 4x16 LCD through pin 3.5, the GSM interface through pin3, and the PNP transistor through its emitter. The transistor is connected to pot 2 pin 4 of the microcontroller. The relay is connected to the collector of the transistor. The voltage transformer primary used for voltage sensing was connected to the life of the mains supply while the secondary is connected to through a variable resistor to ground. Tracing tools of the software is used to check for broken contacts. Programming of 89c52 controller was done and hex files of the programme was generated and saved. The program was simulated and errors from the programme were debugged. Design simulation was done. It was found that the design is practically achievable. The design simulation was tested using graphic tools of Proteus design software and it was observed that a digital system can give only two state of High and Low. A heater was picked from library tools of Proteus of software for test and was observed to energise at High stage and energised at Low stage. The two stages are confirmed, which is an indication that the design is practically achievable. For a better graphic illustration, Op-Amp in non-inverting mode is used to demonstrate the comparative function, which is the attribute used in the programming of the microcontroller.

X. DESIGN CALCULATIONS

i. Power unit

This unit consists of power from mains and the power regulator that provides the regulated voltage. The function of the regulator: 7805 is to convert 230V voltage to 5V DC needed for the normal operation of ADC and microcontroller. The circuit is as shown in Figure 5.

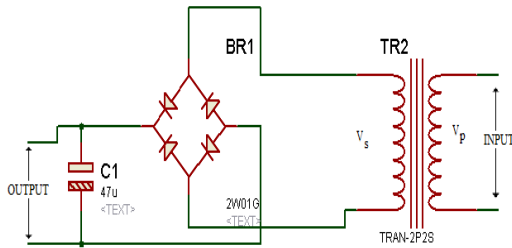

Figure 5: Power supply unit of the circuit diagram

$$V_{dc} = \frac{2V_{RMS}}{\pi} \quad (1)$$

$$V_s = 9V$$

$$V_{dc} = \frac{2V_s\sqrt{2}}{\pi} \quad (2)$$

$$= \frac{2 \times 9\sqrt{2}}{\pi}$$

$$= 3.142$$

$$V_{dc} = 8.1V.$$

Where V_{dc} is the DC Voltage after rectification, V_s is the Voltage at the secondary of the transformer.

Filtering Capacitor of $470\mu f$ is used to filter the voltage ripples, $0.01\mu f$ capacitor is used as surge. 7805 Voltage

Regulator regulates 8.1V to 5V. 5V is used to feed GSM interface, ADC0804, Micro-controller, LCD and PNP Transistor used as switch.

ii. ADC0804 Switching Time

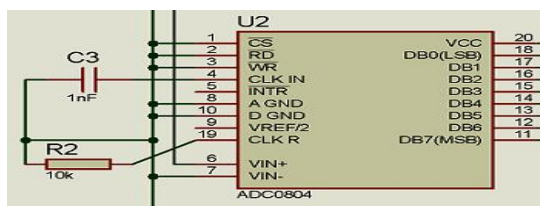

Figure 6: Expression of Switching Property of ADC0804

Figure 6 is a sectional diagram of an Analogue to Digital Converter (ADC). For ADC0804, the switching Time is determined by careful selection of resistor and capacitor, hence the calculation of their value.

$$F_{clk} = \frac{1}{1.1RC} \quad (3)$$

Where F_{clk} is the clocking frequency.

$$T = \frac{1}{F} \quad (4)$$

$$T = 1.1RC$$

$$T \approx 1.1 \times 1 \times 10^3 \times 10^{-9}$$

$$T = 11\mu s.$$

The switching time calculated is suitable for fast switching and conversion of analogue voltage to its digital equivalent.

iii. PNP Transistor as a Switch

A1015silicon PNP transistor is used for circuit switching implementation. Resistor used at the base of the transistor is used for limiting current entering the base against break over hence need for determining an accurate base resistor's value.

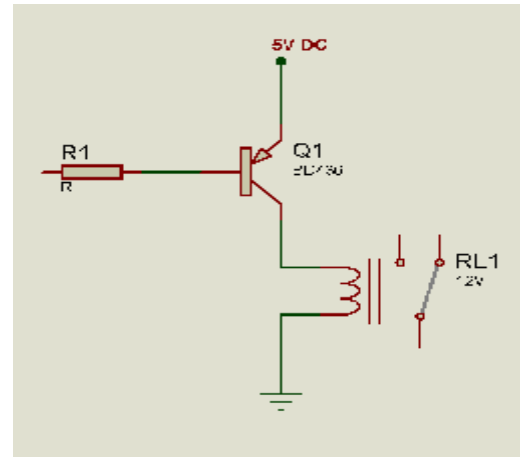

Figure 7: Transistor as a Switch

Maximum base current ($I_{b,max}$) = 50mA and Minimum base current ($I_{b,min}$) = 10μA

$$R_{B,min} = \frac{V_B - V_{BE}}{I_{b,max}} \quad (5)$$

$$R_{B,min} = \frac{5 - 0.7}{0.05} = \frac{4.3}{0.05} = 86\Omega, (R_{B,min} \text{ is the minimum base resistor, } V_B \text{ is the biasing voltage and } V_{BE} \text{ is voltage at emitter base junction})$$

$$R_{B,max} = \frac{V_B - V_{BE}}{I_{b,min}} \quad (6)$$

$$R_{B,max} = \frac{5 - 0.7}{10\mu A} = \frac{4.3}{0.00001} = 430K\Omega, (R_{B,max} \text{ is the maximum base resistor})$$

This implies that the range of resistor to use is from 86Ω to 430KΩ. 10KΩ resistor is used to allow 43 mA current to flow.

iv. Bypass sensing Circuitry

The Current transformer is used for sensing bypass sensor. Figure 8 is a circuitry of half wave rectifier, used to determine bypass Preset Variable Resistor of 10 kilo ohms is used to determine the DC voltage that is sensed in the case theft.

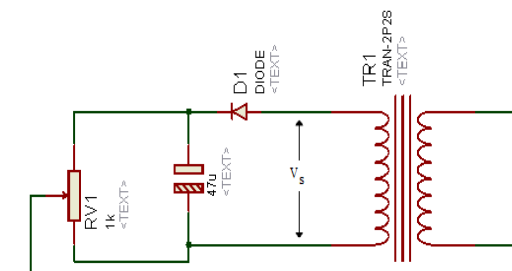

Figure 8: Bypass sensing Circuitry

$$V_{dc} = \frac{V_{RMS}}{\pi} \quad (7)$$

$$V_s = 20V$$

$$V_{dc} = \frac{V_s \sqrt{2}}{\pi} \quad (8)$$

$$V_{dc} = \frac{20\sqrt{2}}{3.142}$$

$$V_{dc} = 9V.$$

Where V_{dc} is the DC Voltage is after rectification, V_s the Voltage at the secondary of the transformer. The Preset Variable Resistor was adjusted to yield 5V from 9V needed to operate the circuit in the case of by-pass.

XI. RESULT AND DISCUSSION

A. SOFTWARE SIMULATION RESULTS

The design of a theft detector device is achieved by the use of Proteus electrical design software for design and simulation, thereby yielding results obtained at different working conditions of a comparator. Micro Controller AT89c52 programmed as comparator can only define two states of High and Low, and hence cannot be suitable for graphical illustration for result presentation, Operational Amplifier is used for simulation analysis. LM741 integrated circuit(IC) is the Operational Amplifier (Op-Amp) used as comparator in non-inverting mode. The comparator is used for comparing the two-voltage input to the Op-Am. Simulation is done by varying the two inputs to obtain an output at theft or no theft conditions.

B. No Theft Condition

This is the condition where there is no meter by-pass. In this case, there would not be potential difference between the two supply inputs, hence as a result there signal generated at the output would not exceed the preset signal value of the comparator circuit as presented in Table 1 the corresponding graph from the simulation is as shown in Figure 9.

Table 1: Equal voltage inputs and constant output voltage

"TIME"	"VO"	"V2"	"V1"
0	3.88109	-0.001	-0.0006
1.33E-05	3.88154	0.01977	0.02012
4.43E-05	3.88157	0.0679	0.06824
7.95E-05	3.8816	0.12266	0.123
0.000149925	3.88166	0.23212	0.23246
0.000290791	3.88179	0.45066	0.451
0.000572524	3.88204	0.88466	0.885
0.00113599	3.88254	1.72852	1.72886
0.001802657	3.88292	2.65514	2.65547
0.002469324	3.8833	3.46567	3.46601
0.00313599	3.88369	4.1247	4.12504
0.003802657	3.88374	4.60341	4.60375
0.004469324	3.8838	4.8809	4.88123
0.00513599	3.88386	4.94502	4.94536
0.005802657	3.88358	4.79298	4.79331
0.006469324	3.8833	4.43142	4.43176
0.00713599	3.88302	3.87614	3.87648
0.007802657	3.88245	3.15142	3.15176

The two voltage inputs V_1 and V_2 are fed to the comparator, both input voltages are at the same potential, hence there is no potential difference as shown that V_1 and V_2 overlapped each other from the graph in Figure 9. Therefore V_0 is constant with preset voltage value and no pulse is generated at the output in order to trigger communication circuit. Digital Oscilloscope is used to measure potential at different instances

C. Theft Condition

This is the condition where there is by-pass. In this case, there

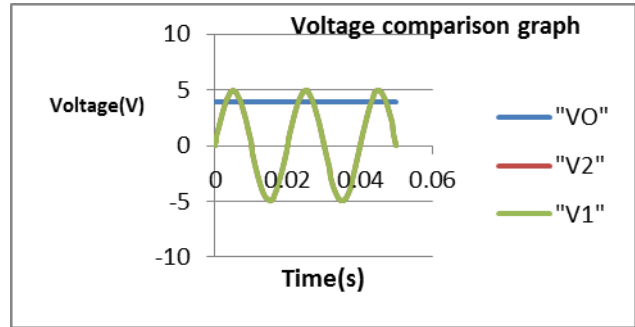

would be potential difference between the supplied voltages inputs of the comparator and as a result, there would be voltage signal generated at the comparator's output. The inputs and output voltage values are shown in the Table 2 and corresponding graph of the comparator circuit is also shown in Figure 10. The input voltages V_1 and V_2 varies as a result of meter bypass which resulted to output voltage V_0 as seen from the voltages displayed on the graph of Figure 10.

Table 2: Different voltage inputs and output voltage comparator

"TIME"	"VO"	"V2"	"V1"
0	3.88109	-0.001	-0.0006
6.67E-06	3.54121	0.01114	0.00179
8.42E-06	3.42477	0.01433	0.00243
1.19E-05	3.12925	0.02071	0.00369
1.90E-05	2.2607	0.03348	0.00621
3.30E-05	-0.3681	0.05908	0.01119
4.53E-05	-3.3953	0.08161	0.01549
5.18E-05	-3.969	0.09349	0.01773
5.95E-05	-3.9773	0.10766	0.02039
6.60E-05	-3.974	0.11953	0.02261
7.42E-05	-3.9743	0.13447	0.0254
9.05E-05	-3.9748	0.16438	0.03096
0.000123039	-3.9749	0.22418	0.04206
0.000168805	-3.975	0.30815	0.05764
0.000238966	-3.9751	0.43666	0.08158
0.000379289	-3.9751	0.66395	0.15836
0.000659935	-3.9751	0.99094	0.43411

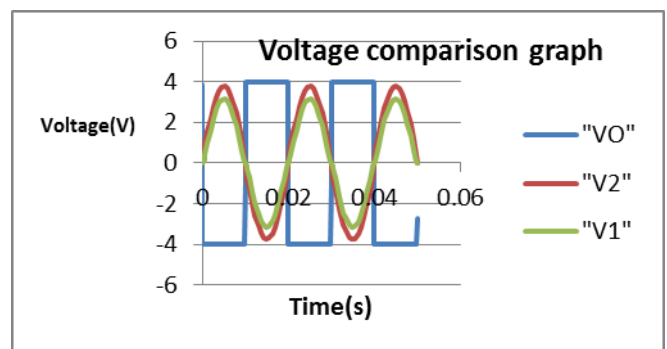

Figure 10: A simulated graph of voltage difference of inputs: V_1 and V_2 and output V_0 to the comparator. The Table 2 is an extract of table obtained from the simulation.

XII. CONCLUSION

The set objectives of this work were achieved by carrying out GIS implementation, which involves data acquisition, classification processing and presentation as demonstrated in Figure 2. Circuit was designed and analysed under two conditions of theft and no theft. In conclusion, data querying was done in the case of meter bypass, and the result of the query showed the customer's name, geographical coordinated and physical address.

However challenges encountered includes difficulties in data sourcing through device use, software functionality and understanding, questionnaire attendance reliability and difficulties in acquiring components needed for the design.

XIII. RECOMMENDATION

This research work cut across other disciplines such as geosciences and computer science and other area of improvement includes:

- Having detected the customers involved in electricity theft, further research should be made in order to remotely control supply to customers involved.
- Design of interactive comparative system that would be installed at an electrical pole in an area that supplies several customers' premises is recommended. The system is expected to synchronise with the already designed electrical theft detection system in order to detect discrepancies.
- Microcontroller instructs the communication circuit to send out instant messages at a time when meter is bypassed, but does not estimates the duration electricity theft last. This can be improved on, so as to acquire interval update report on theft.

REFERENCES

- [1]. Sule, H. A. (2010). Major Factors Affecting Electricity Generation., *International Journal of Engineering and Mathematical Intelligence*, 1(1&3), 159.
- [2]. Sharma, J. D., Priyanka, D.& Singhal, M. K. (2008). GIS and GPS Based Preliminary Distribution System Planning. *National Conference on Emerging trends and advances in Electrical Engineering and Renewable Energy (NCEEERE)*. India: Sikkim Manipal Institute of Technology.
- [3]. Thakur, T., Deshmukh, S. G., Kaushik, S. C.& Kulshrestha, M. (2004). Impact assessment of the Electricity Act 2003 on the Indian power sector. *Elsevier*, 1-12.
- [4]. Titus, O. K., Jumah, A.-G. A.& Phillips, D. A. (2013). The current and future challenges of electricity market in Nigeria in the face of deregulation process. *African Journal of Engineering Research*, 1(2), 33-39.
- [5]. Damian, O. D., Uchechukwu, A. O., Euphemia, C. N.& Blessing, C. D. (2015). Minimizing Household Electricity Theft in Nigeria Using GSM Based Prepaid Meter. *American Journal of Engineering Research (AJER)*, 59-69.
- [6]. Sambo, A. S. (2008). *Matching Electricity Supply with Demand in Nigeria*. Abuja, Nigeria: Federal Ministry of Energy (Power Sector).
- [7]. Olivia Phillip International Consulting Limited (2013). *Electric Power Sector Report 2013*. Nigeria: The West African Transformer Market by Frost & Sullivan.
- [8]. Theraja, B.& Theraja, A. K. (2005). *A TextBook on Electrical Technology*. India: S.C Chand.
- [9]. Smith, P. H. (2005). *Electrical Distribution Modeling: An Integration of Engineering Analysis and Geographic Information Systems*. Thesis submitted to the Faculty of the Virginia Polytechnic Institute and State University, Blacksburg, Virginia.
- [10]. Yadav, S. K. (2013). GIS in Power Sector Management. *International Journal of Engineering Research and Technology*, 759-766.
- [11]. Damilola, D. A. (2013). Geospatial modeling of electricity distribution network. *Geospatial World Weekly* .

- [12]. Sipes, J. L. (2007). *GIS for the Utilities Industry*. Retrieved on April 21, 2015 from: <http://www.cadalyst.com/gis/gis-utilities-industry-spatial-tech-column-9178>
- [13]. Ayeni, O. O., Saka, D. N.& Ikwuemesi, G. (2003). Development a Multimedia Database for Tourism Industry in Nigeria. *Journal of Photogrammetry and Remote Sensing*, 1-5.
- [14]. Emengini, J. E.& Idhoko, K. (2013). GIS in Management of Water Distribution Network of Onitsha-North L.G.A., Anambra State, Nigeria. *International Science Research Journal*, 35-41.

Engineer Mathew Chkwu Udo (M. Eng) is a graduate of Electrical/Computer engineering, option in Power Engineering, his research interest is in power system, and he is a member of council of registration of engineers in Nigeria.

Mr. Joseph Elijah (M. Eng) is a lecturer in the Department of Mathematics/Computer Science, IBB University, Lapai, Nigeria. His current research interests include: Image processing, Modelling and Simulation, intelligent systems and Computer networks. He is a member of International association of Engineers (IAENG) with membership number: 126514.

Dr. Amit Mishra (PhD) is a lecturer in the Department of Mathematics/Computer Science, IBB University, Lapai, Nigeria. His current research interests include: Network security, Cryptology, Machine learning, Software Engineering, Reverse Engineering. He has been publishing in the above-mentioned fields in various national and international journals. He is also Microsoft Certified professional in Win2K and Exchange Server.

Mr. Idris Rabi (M.Sc.) is a lecturer in the Department of Mathematics/Computer Science, IBB University, Lapai, Nigeria. His research interests include: Performance modelling and analysis of computer and communication systems, systemic routing schemes in data Communication, Wireless/Mobile systems, Computer Networks and Network Security.

Professor S.S Farinwata (MFR) is the Head of Department Mechatronic and System Engineering. Abubakar Tafawa Balewa University, Bauchi Nigeria.