

Controller Energy management for hybrid renewable energy system

Mokhtar Said El-Negamy, Abeer Galal, G.M. El-Bayoumi

Abstract— A new modified configuration for the stand-alone photovoltaic- wind – diesel generator system with and without battery to electrify a remote area household load in Egypt is presented. The displaying, reenactment, and operational control technique for the framework is produced. The created control intends to enhance the energy flow inside the framework, with the end goal that the heap is fulfilled autonomous on the varieties in insolation, the temperature and the wind speed. Additionally, it means to ensure the battery against overcharging or excessive discharging. Also, it means to secure the worldwide framework against the unpredictable excess or deficit of the available energy.

Index Terms— Remote area electrification, PV array, Wind turbine, Storage battery, Diesel generator, ON-OFF control, Energy management.

I. INTRODUCTION

Renewable vitality sources are considered as option vitality sources to customary fossil fuel energy sources because of ecological contamination and an Earth-wide temperature boost issues [1]. One of these, most critical, sources is the photovoltaic (PV) modules and wind turbine, which might be outfitted with capacity batteries to supply electrical energy to remote areas overall [2-6].

The arrangement of power to remote ranges determines critical social and monetary advantages to remote groups all through the world. The regular design of PV frameworks that is typically utilized for this reason for existing is the remain solitary sort [6, 7]. Where, stand-alone photovoltaic-wind – diesel generator framework with and without battery can be considered as dependable and conservative wellsprings of power in remote regions, which are a long way from the matrix control supply [5, 8-14].

The power supplied by a PV cluster relies on the insolation level and cell temperature. Battery shapes a vital component of stand-alone photovoltaic-wind – diesel generator framework, as a result of the fluctuating way of the yield conveyed by the PV exhibits and the wind turbine. Both the battery voltage and the PV cluster voltage change amid operation because of the charging condition of the battery and the climatic conditions [7, 8, 15].

Mokhtar Said El-Negamy, Electrical Engineering Department, faculty of engineering Fayoum University, Fayoum, Egypt.

Abeer Galal, Electrical Engineering Department, faculty of engineering Fayoum University, Fayoum, Egypt.

G.M. El-Bayoumi, Aerospace Engineering Department, faculty of engineering, Cairo University, Giza, Egypt.

In this paper another adjusted setup for the remain solitary photovoltaic-wind – diesel generator framework with and without battery, which incorporates a capacity battery, is introduced to jolt a remote region family unit stack in Red Sea city of Egypt. Additionally, the finish demonstrating and control of this framework is created and reproduced; to show the capacity of the created control methodology in controlling and ensuring the altered design of the remain solitary photovoltaic-wind – diesel generator framework with and without battery.

II. MODELING OF HYBRID RENEWABLE ENERGY SYSTEM COMPONENTS.

To build up a general power administration procedure for the proposed hybrid framework and to examine the framework execution, numerical displaying of the parts has been produced. One model for PV-Wind-Diesel generator hybrid framework is clarified in figure1. Second model for PV-Wind-Diesel generator hybrid system with battery storage is explained in figure2. A brief depiction for displaying of PV-Wind-Diesel generator hybrid system and PV-Wind-Diesel generator hybrid system with battery storage is prepared for feeding any load in any site.

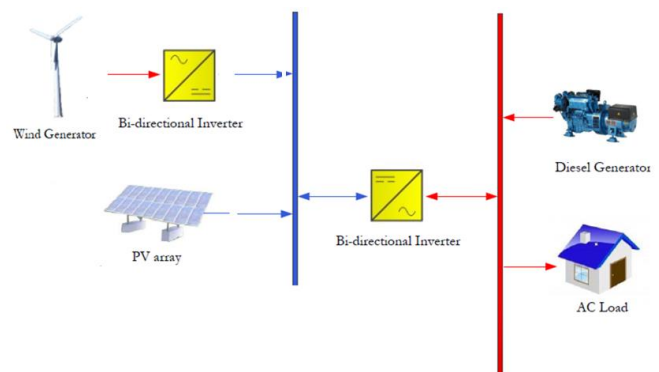

Figure1. Configuration of PV-Wind-Diesel generator hybrid system

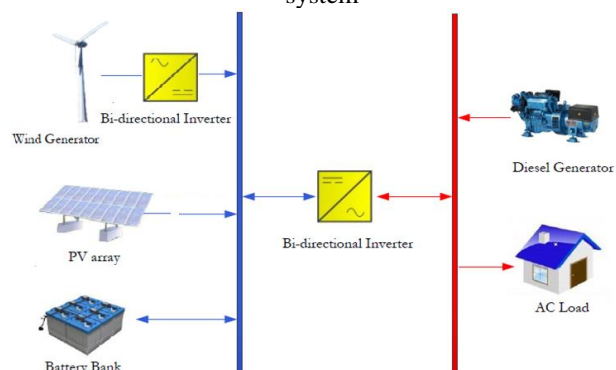

Figure2. Configuration of PV-Wind-Diesel generator hybrid system with battery storage

A. PV Module Performance Model

A PV module comprises of various sun based cells associated in series and parallel to get the craved voltage and current yield levels. Each sun based cell is fundamentally a p-n diode. As daylight strikes a sun oriented cell, the occurrence energy is changed over straightforwardly into electrical energy with no mechanical effort. Transmitted light is acclimatized inside the semiconductor, by utilizing this light energy to energize free electrons from a low energy status to an empty higher energy level. At the point when a sun powered cell is lit up, overabundance electron-opening sets are created all through the material; consequently the p-n intersection is electrically shorted and current streams. Single-diode mathematic model is applicable to simulate silicon photovoltaic cells, which consists of a photocurrent source I_{ph} , a nonlinear diode, and internal resistances R_s and R_{sh} , as shown in Figure 3 [16-17].

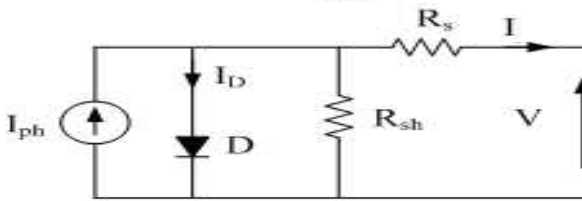

Figure3. Equivalent circuit of a solar panel.

Applying Kirchoff current law, the output current (I) of the PV module can be obtained as:

$$I = I_{ph} - I_D - I_{sh} \quad (1)$$

Where, I_{sh} is the shunt-resistance current and is given by:

$$I_{sh} = \frac{V + IR_s}{R_{sh}} \quad (2)$$

Where V is the terminal voltage of the PV module

Also I_D is the diode current and is given by:

$$I_D = I_o \left[e^{\frac{V + IR_s}{aV_T}} - 1 \right] \quad (3)$$

Where I_o is the reverse saturation current,

a is an empirical non-ideality factor for the diode

V_T is the junction thermal voltage and is given by:

$$V_T = \frac{N_s K T_c}{q} \quad (4)$$

Where N_s is the series-connected solar cells per module,

q is the electron charge = $1.60217646 \times 10^{-19}$ C,

k is Boltzmann constant = $1.3806503 \times 10^{-23}$ J/K,

T_c is the absolute cell temperature in Kelvin.

Substituting the shunt resistance current and diode current values in equation (1), then

$$I = I_{ph} - I_o \left[e^{\frac{V + IR_s}{aV_T}} - 1 \right] - \frac{V + IR_s}{R_{sh}} \quad (5)$$

The power output of the photovoltaic array at time t is:-

$$P_{pv} = I \times V \quad (6)$$

$$P_{pv} = \left(I_{ph} - I_o \left[e^{\frac{V + IR_s}{aV_T}} - 1 \right] - \frac{V + IR_s}{R_{sh}} \right) \times V \quad (7)$$

Generally, the manufacturers of PV modules provide information at certain points on the PV characteristic; such as the short-circuit current (I_{sc}), open-circuit voltage (V_{oc}), and the maximum power point current (I_{mp}) and voltage (V_{mp}),

which are called remarkable points. Moreover, the temperature coefficients for I_{sc} and V_{oc} are also provided in the manufacturer sheet as K_i and K_v respectively. Always K_i is positive temperature coefficient, but K_v is negative temperature coefficient. Also the number of series-connected cells per module (N_s) is provided.

B. Wind Turbine Performance Model.

The WTG produces power P_w when the wind speed V is higher than the cut-in speed V_{ci} and is shut-down when V is higher than the cut-out speed V_{co} [18-19]:

$$P_w = \begin{cases} P_r \left(\frac{V^3 - V_{ci}^3}{V_r^3 - V_{ci}^3} \right) & V_{ci} \leq V \leq V_r \\ P_r & V_r \leq V \leq V_{co} \\ 0 & V_{co} \leq V \text{ or } V_r \leq V_{ci} \end{cases} \quad (8)$$

C. Meteorological data and Load Profile.

The proposed method is to optimally size a PV-wind hybrid energy system to electrify a residential remote area household near Red Sea city of Egypt. The considered site has latitude is $27^\circ 17'$ and longitude is $33^\circ 46'$. Figures 4 show these data (i.e., the global solar insolation) during the 12 months of a typical year.

Figure 5 illustrates the considered residential remote area load profile, during the 12 months of the year.

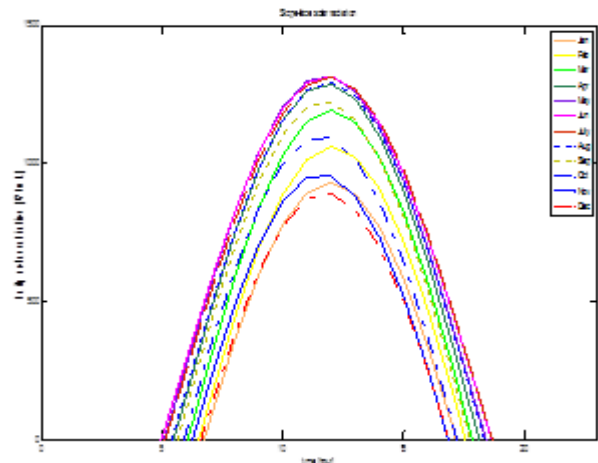

Figure4. Variation of Solar radiation over the year

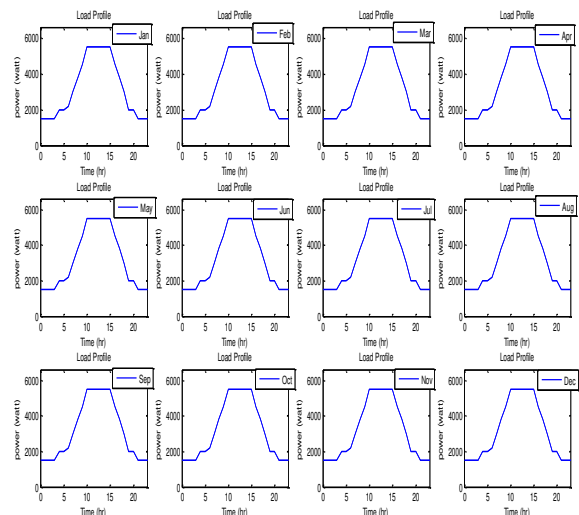

Figure5. Variation of Load over the year

III. MODES OF OPERATION

The hybrid renewable energy system has several modes of operation. These modes are dependent on the variation of the metrological data. Figure6. Shows that, The mode-1 operation of the hybrid renewable energy system. In this mode the sources of energy are photovoltaic module, diesel engine generator and battery storage.

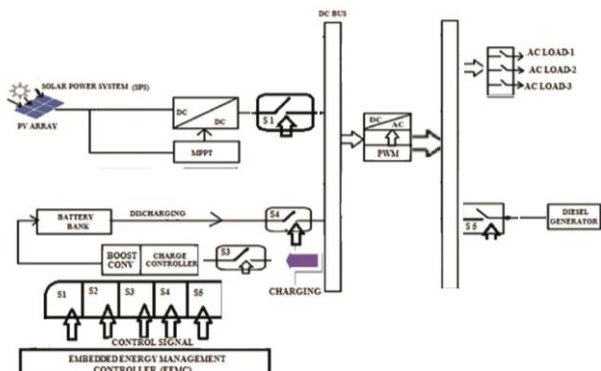

Fig6. Block diagram of mode 1

Figure7. shows, the mode-2 operation of the hybrid renewable energy system. In this mode the sources of energy are photovoltaic module and battery storage.

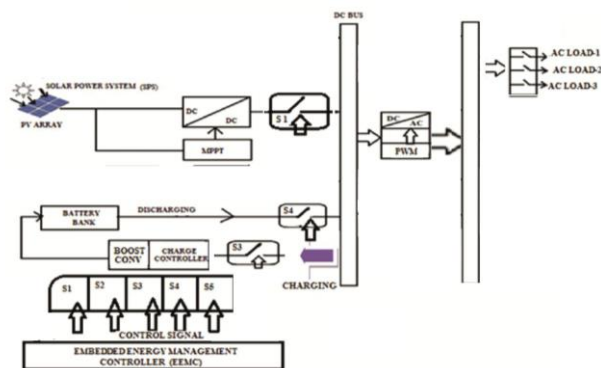

Fig7. Block diagram of mode 2

Figure8. shows, the mode-3 operation of the hybrid renewable energy system. In this mode the sources of energy are Wind turbine, diesel engine generator, and battery storage.

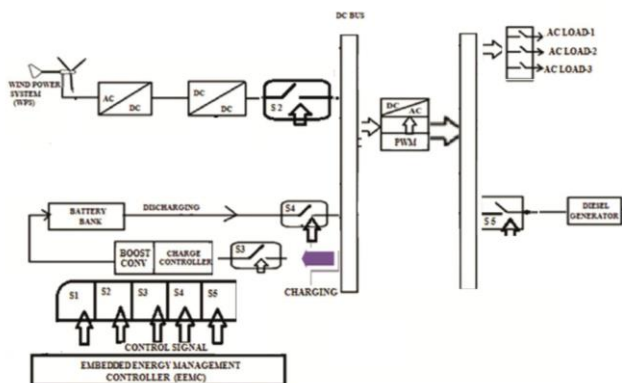

Fig8. Block diagram of mode 3

Figure9. shows, the mode-4 operation of the hybrid renewable energy system. In this mode the sources of energy are Wind turbine and battery storage.

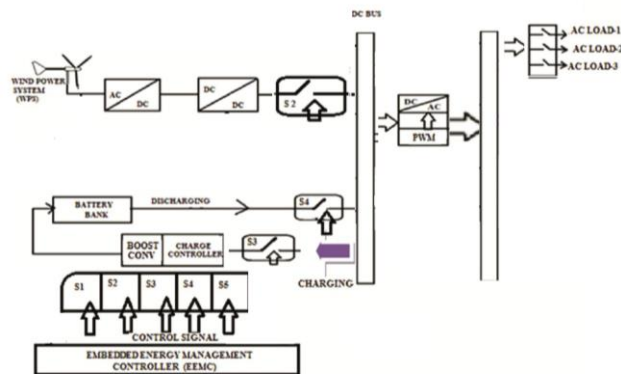

Fig9. Block diagram of mode 4

Figure10. shows, the mode-5 operation of the hybrid renewable energy system. In this mode the sources of energy are photovoltaic module, wind turbine, diesel engine generator, and battery storage.

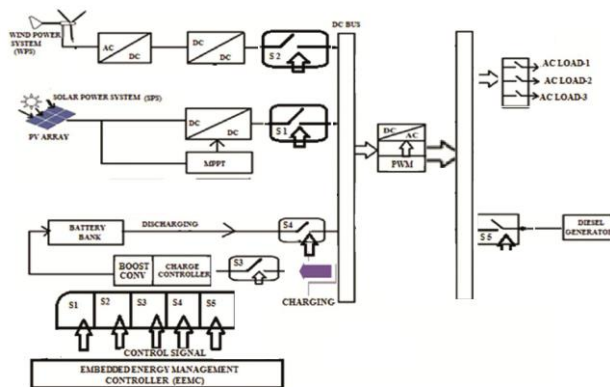

Figure10. Block diagram of mode 5

Figure11. shows, the mode-6 operation of the hybrid renewable energy system. In this mode the sources of energy are photovoltaic module, wind turbine and battery storage.

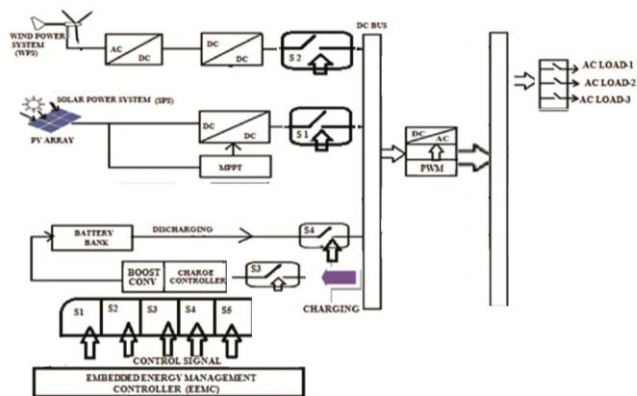

Figure11. Block diagram of mode 6.

IV. RESULTS

Stand-alone PV-wind-diesel generator frameworks for remote region family unit zap must be absolutely independent in creating, putting away and supplying power to the family unit electrical load. These frameworks are subjected upstream to the flighty varieties in sunlight based insolation and/or surrounding temperature and downstream to the family unit

electrical load. In this way, these frameworks must require certain control system to ideally deal with the energy flow inside them. Where, in this work, the composed control procedure can decide the present condition of the framework and thusly can issue the proper requests or orders went for enhancing the energy exchange work inside the framework, to satisfy the specialized necessities of the framework. The primary motivations behind the composed control technique are to fulfill the family unit electrical load and to discharge or charge the capacity battery at whatever point conceivable. In addition, the planned control methodology can shield the capacity battery from unreasonable discharge and overcharge, and in the meantime it can shield the worldwide framework from the capricious abundance or shortage of the accessible vitality. The planned control procedure, as appeared in the flowchart of Figure12, depends on the IF-THEN standards; with the end goal that the IF-part of a run speaks to the present condition of the framework, while the THEN-part speaks to the appropriate issued-control order of the framework. For each mode, the time at which each component is operated to feed the load must be identified to the energy management controller. This duration of operation for each component is determined according to the flowchart in figure12 using m-file code in matlab.

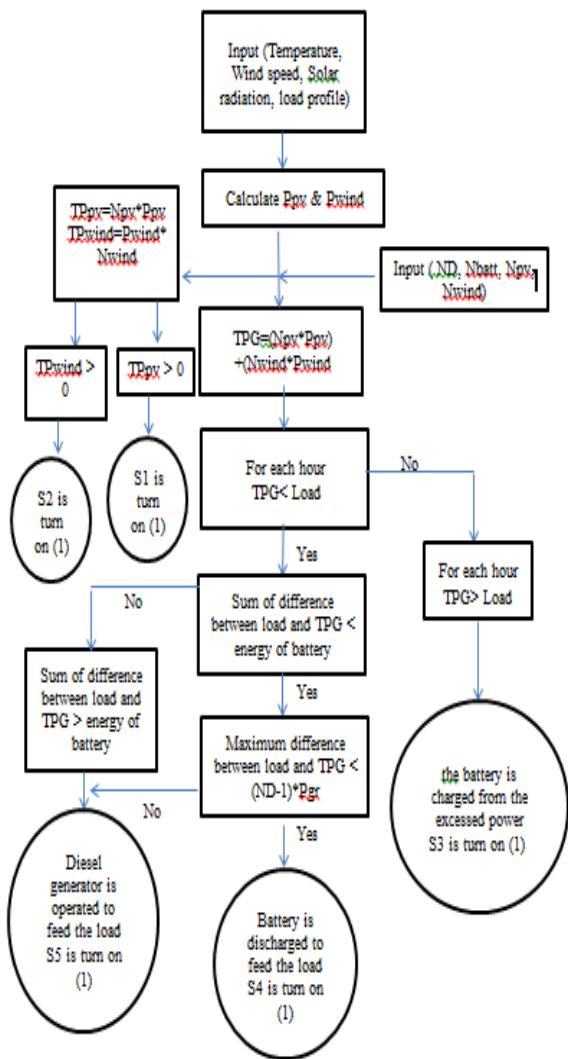

Figure12. flowchart for controller energy management.

Mode1: The optimum sizing of the (photovoltaic module – wind turbine) HRES is stand-alone photovoltaic with battery storage (28 module of PV, 3KW diesel generator, and 2 battery storage of 250 Ah). This system gives LPSP=0.0191. After applying this case to the program, the operation period for each component in the system is obtained as shown in figure13.

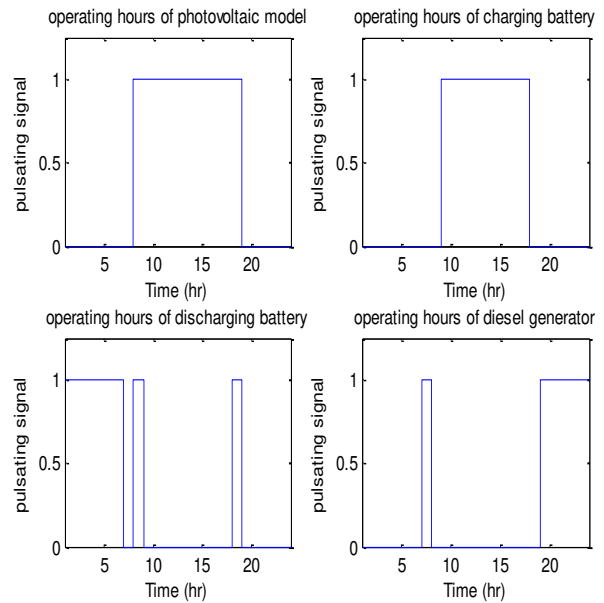

Figure13. The operating hours for each switch in mode1.

Mode2:- The optimum sizing of the (photovoltaic module – wind turbine) HRES is stand-alone photovoltaic with battery storage (29 module of PV, and 3 battery storage of 250 Ah). This system gives LPSP= -0.0159. After applying this case to the program, the operation period for each component in the system is obtained as shown in figure14.

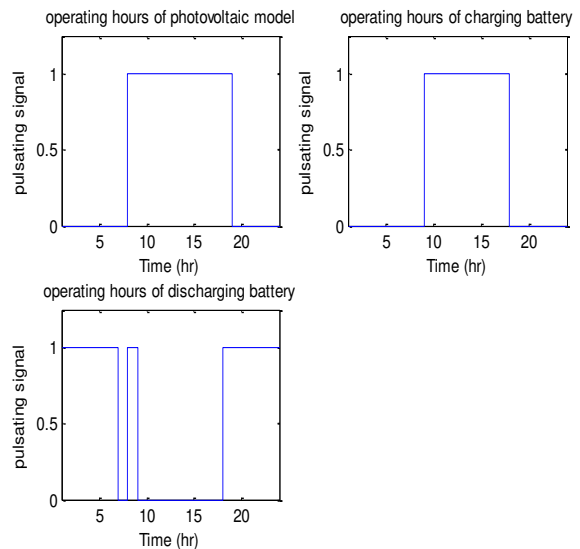

Figure14. The operating hours for each switch in mode2.

Mode3:- The optimum sizing of the (photovoltaic module – wind turbine) HRES is stand-alone wind turbine with battery storage (83 wind turbine, 2KW diesel generator, and 1 battery storage of 250 Ah). This system gives LPSP= 0.0164. After applying this case to the program, the operation period for each component in the system is obtained as shown in figure15.

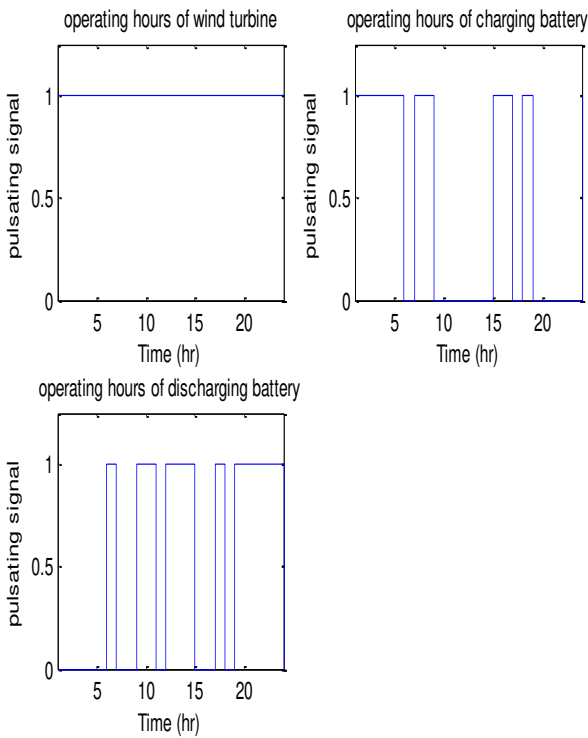

Figure 15. The operating hours for each switch in mode3.

Mode4:- The optimum sizing of the (photovoltaic module – wind turbine) HRES is stand-alone wind turbine with battery storage (85 wind turbine, and 1 battery storage of 250 Ah). This system gives LPSP=-0.0073. After applying this case to the program, the operation period for each component in the system is obtained as shown in figure16.

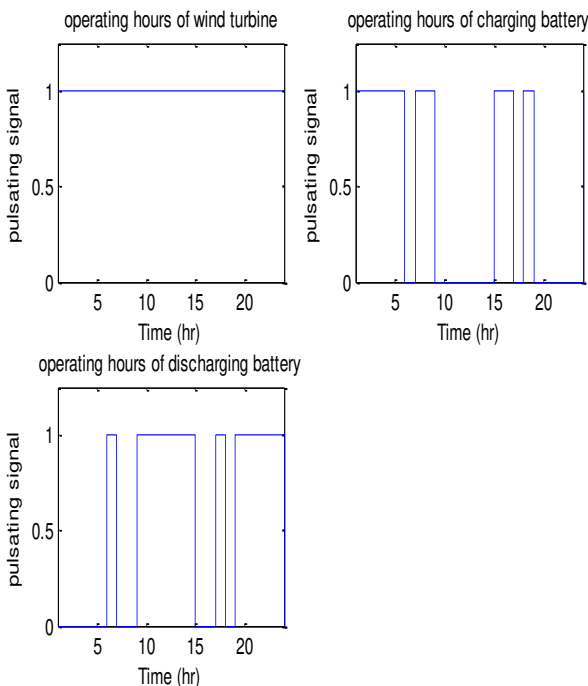

Figure 16. The operating hours for each switch in mode4.

Mode5:- The optimum sizing of HRES is (photovoltaic module – wind turbine) with battery storage (23 module of PV, 16 wind turbine, 3KW diesel generator and 2 battery storage of 250 Ah). This system gives LPSP= 0.0047. After applying this case to the program, the operation period for each component in the system is obtained as shown in table5.

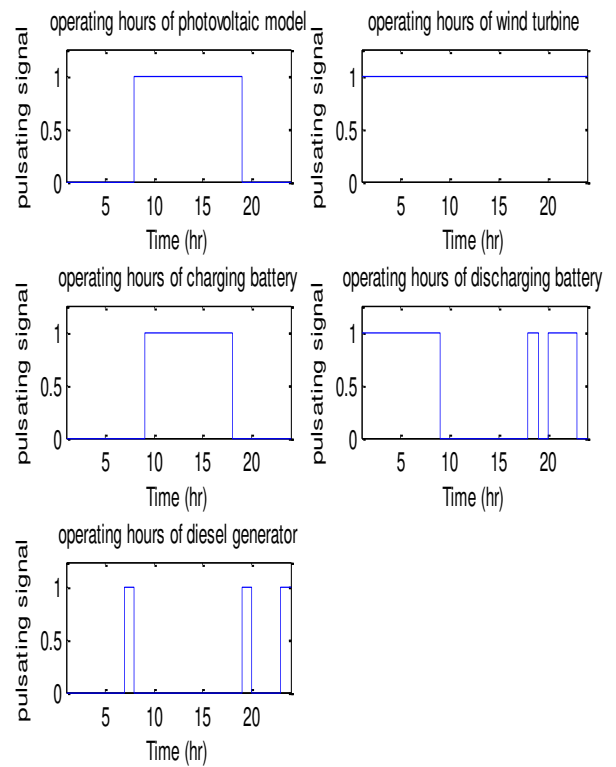

Figure 17. The operating hours for each switch in mode5.

Mode6:- The optimum sizing of HRES is (photovoltaic module – wind turbine – diesel generator) with battery storage (23 module of PV, 17 wind turbine, and 2 battery storage of 250 Ah). This system gives LPSP= -0.0072. After applying this case to the program, the operation period for each component in the system is obtained as shown in figure18.

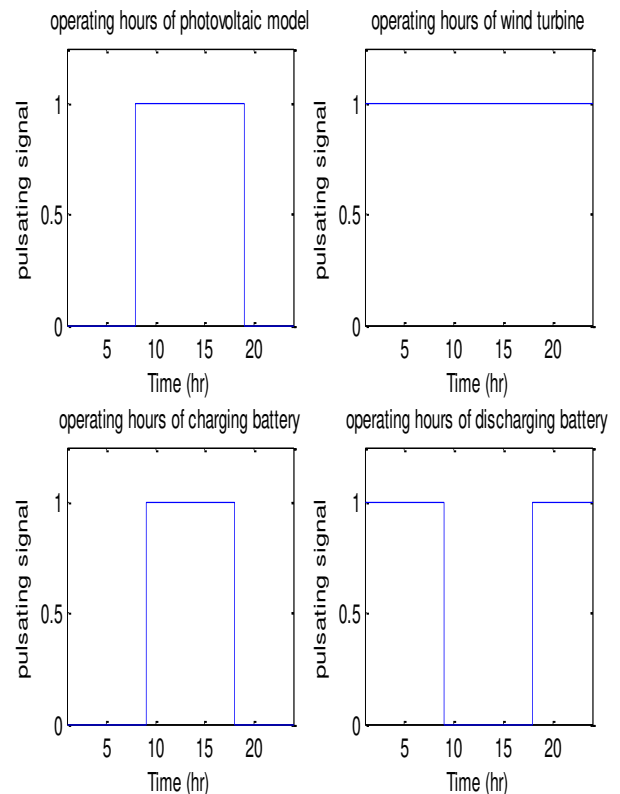

Figure 18. The operating hours for each switch in mode5.

V. CONCLUSION

The optimum solution of sizing PV-wind turbine- diesel generator hybrid energy system with and without battery storage is developed. In case of Photovoltaic- wind turbine –diesel generator hybrid energy system without battery storage, there are exceed energy produced from the photovoltaic module is unusable, the generator is used extensively and this lead to emission of gases.so that the battery is added to improvement the system.

Comparison between modes of operation is provided to explain the relation between the total generated powers and the load demands, and to indicate the state of charge and discharge of the battery.

A Control strategy between the components of the Hybrid System with and without battery storage system is developed. The system having a PV panel, WT, DG, and battery storage for continuous power flow management. The nature of renewable resources is discontinuous, so that generator is used to modify this uninterrupted energy. The power from load demand and all resources continuously are monitored and controlled by controller energy management

REFERENCES

- [1] Islam, S.; Belmans, R. *Grid Independent Fuel-Cell Hybrid System: Optimal Design and Control Strategy*, Proceeding of the 19th European Photovoltaic Solar Energy Conference, Paris, France, **2004**, Vol. 3, pp. 3311-3314.
- [2] Sanidad, L.; Parsons, R.; Baghzouz, Y. Boehm, R. *Effect of ON/OFF Charge Controller on Stand-Alone PV System Performance*, American Institute of Aeronautics and Astronautics, Inc., **2000**.
- [3] Taylor, R.; Abulfotuh, F. *Photovoltaic Electricity in Egypt*, Project Brief. <http://www.rsvp.nrel.gov> (accessed 2005).
- [4] Vankeleom, J.; Dufourd, F.; Saleh, L.A. *ELVIRA: A Software for Rural Electrification in Developing Countries - Application for the Use of Photovoltaic Energy in Egypt*, Proceedings of the 19th European Photovoltaic Solar Energy Conference, Paris, France, June **2004**, Vol. 3, pp. 3452-3455.
- [5] Nafeh, A.A. Design and economic analysis of a stand-alone pv system to electrify a remote area household in Egypt. *Open Renewable Energy J.*, **2009**, 2, 33-37.
- [6] Moseley, P.T. Energy storage in Remote Area Power Supply (RAPS) systems. *J. Power Sources*, **2006**, 155, 83-87.
- [7] Markvart, T. *Solar Electricity*. John Wiley & Sons: New York, **1994**.
- [8] Ishengoma F.M.; Norum, L.E. Design and Implementation of a Digitally Controlled Stand-Alone Photovoltaic Power Supply, *Proc. of the Nordic Workshop on Power and Industrial Electronics (NORPIE/2002)*, Stockholm, Sweden, **2002**, pp. 1-5.
- [9] Ashok, S. Optimized model for community-based hybrid energy system. *Renewable Energy*, **2007**, 32, 1155-1164.
- [10] Al-Alawi, A.; Al-Alawi, S.M.; Islam, S.M. Predictive control of an integrated pv-diesel water and power supply system using an artificial neural network. *Renewable Energy*, **2007**, 32, 1426-1439.
- [11] Shaahid, S.M.; I. El-Amin, I. Techno-economic evaluation of offgrid hybrid photovoltaic–diesel–battery power systems for rural electrification in Saudi Arabia—a way forward for sustainable development. *Renewable Sustainable Energy Rev.*, **2009**, 13, 625- 633.
- [12] Kaldellis, J.K.; Zafirakis, D.; Kaldelli, E.L.; Kavadias, K. Cost benefit analysis of a photovoltaic-energy storage electrification solution for remote Islands. *Renewable Energy*, **2009**, 34, 1299-1311.
- [13] Benganem, M. Low cost management for photovoltaic systems in isolated site with new iv characterization model proposed. *Energy Convers. Manage.*, **2009**, 50, 748-755.
- [14] Moharil, R.M.; Kulkarni, P.S. A case study of solar photovoltaic power system at sagardeep Island, India. *Renewable Sustainable Energy Rev.*, **2009**, 13, 673-681.
- [15] Prasad, A.R.; Natarajan, E. Optimization of integrated photovoltaic-wind power generation systems with battery storage. *Energy*, **2006**, 31, 1943-1954.

- [16] A.McEvoy, T.Markvart, and L. Castaner, *Practical Handbook of Photovoltaics : Fundamentals and Applications*, Academic Press, Amsterdam, The Netherlands, 2012.
- [17] Mokhtar said El-Negamy, Abeer galal, G.M.El-bayoumi, " Extraction of The unknown Parameters of a Photovoltaic Module from Manufacture Data Sheet", international journal of innovative science and modern engineering, ISSN 2319-6386, 2015, volume 3- issue 10,Page No.: 6-13, September 2015.
- [18] Borowy, B.S., and Z.M. Salameh. 1996. Methodology for optimally sizing the combination of a battery bank and PV array in a wind/PV hybrid system. *IEEE Transactions on Energy Conversion*11(2): 367–375.
- [19] Rios Rivera M (2008) Small wind/photovoltaic hybrid renewable energy system optimization. Master of Science, Electrical Engineering, Puerto Rico, Mayaguez Campus.



Mokhtar Said Ibrahim Ahmed born on September 24, 1987 in Ehnasi El-Khadra, Bani suef, Egypt. He completed his B.E. in Electrical Engineering from Faculty of Engineering, Fayoum University in 2009. He completed his M.Sc in Electrical Engineering from Faculty of Engineering, Fayoum University in 2013. He is currently pursuing his PhD in Electrical Engineering from Faculty of Engineering, Fayoum University. His field of interest is Power Systems, Renewable energy.