

Improved Enhanced Version Of Solar Photo Voltaic System

J.Joan vinith, R.M.Sekar

Abstract— The photovoltaic (PV) panel depends on irradiance, temperature and load. The power produced in this system is not optimal. Hence, maximum power is extracted from PV array. MPPT varies the electrical operating point of the PV modules which delivers maximum available power. A new model designed that uses open circuit voltage and short circuit current, sampled from a reference PV Panel. Using these measurements the maximum power is been tracked from main panel without breaking the power transferred to load. A DC-DC converter was used to transfer maximum power between source and load .

Index Terms— photovoltaic system, maximum power point tracking, buck boost converter

I. INTRODUCTION

Photovoltaic systems consists of solar cells, connection, protection, storage components. The solar cells have specific features like initial investment cost, quality and quantity. Hence, it is very important to design at best conditions and effectively. Power converters uses Maximum Power Point Tracker (MPPT). The task of MPPT is to regulate the actual operation voltage of PV panel to the voltage at MPP. MPPT adjusts the output power of DC converter which is transferred to the load. The main criteria in the selection of MPPT algorithms are as follow.

- i. Ease of Implementation
- ii. The required number of sensors. Voltage measurement is usually easier and more reliable than current. Current sensors are also often expensive and cumbersome structure
- iii. Due to a partial shading on PV, panels may affect the normal operation of the MPPT
- iv. Determination of the cost of an MPPT before implementation is important. Generally analog algorithms are cheaper than digital ones

II. MPPT ALGORITHMS

A new MPPT algorithm is designed that uses open circuit voltage and short circuit current, sampled from a reference PV Panel. Using these measurements the maximum power is been tracked from main panel without breaking the power transferred to load. The proposed algorithm was checked for its performance in local environmental condition.

A. Methodology

The output power from the PV system depends on PV cell efficiency, irradiation, cell temperature and load impedance. The Maximum Power Point Tracking (MPPT) involves

J.Joan Vinith, currently pursuing his Master of Engineering in PSNA College of Engineering and Technology, Dindigul, Tamilnadu, India

R.M.Sekar, received the M.Tech degree in Power Electronics from VIT University, India, in 2004. He is currently working as an assistant professor in PSNA College of Engineering and technology, Dindigul, Tamilnadu, India

the adjustment of output voltage and/or current of the PV system for given load, irradiation and cell temperature. Tracking maximum power not only increases the power output, but also increases the life of the system. So far, different types of MPPT methods have been developed and employed. These methods can be differentiated depends on the sensors used, convergence speed, cost, range of effectiveness, implementation hardware requirements and popularity. Based on the approach used for generation of the control signal, these methods are categorized as online method, offline method and hybrid method.

Offline method is very simple and further classified into open circuit voltage (OCV) method and short circuit current (SCC) method. Open circuit voltage (Voc) method uses approximate linear relation between OCV and maximum power point voltage (Vmpp) at different environment conditions Equation (1). Short circuit current (Isc) method also uses approximate linear relation between SCC and maximum power point current (Impp) at different environment conditions Equation 1.

$$V_{mpp} = K_1 V_{oc} \quad (1)$$

$$I_{mpp} = K_2 I_{sc} \quad (2)$$

Where k_1 and k_2 are constants depend on the solar cell characteristics. The SCC method is more accurate and efficient than the OCV method. The main demerits of the offline method is load interruption.

In online procedures, the instant values of the PV output voltage or current are used to generate the control signals. This includes perturbation and observation method (P&O). The problems associated with this method are amplitude of perturbation and rate of convergence.

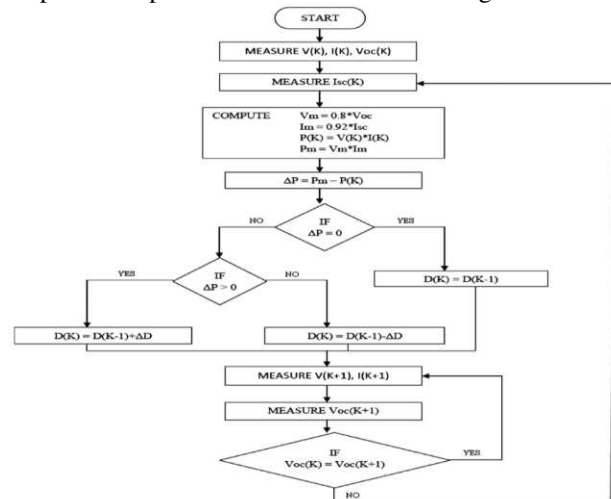

Fig.2.1 Flow chart of proposed MPPT algorithm

TABLE 2.1 DETAILS OF THE PV PANEL

Solar panel model	USL12 (Udhayaphotovoltaics)	
Panel power	12 Wp	
Maximum voltage	17.1 V	
Maximum current	0.70 A	
Open circuit voltage	21.5 A	
Short circuit current	0.79 A	

It studied and compared the work done by different researchers on hybrid MPPT system with the combination of any on offline method. Working value of various MPPT techniques are matched with each other in terms of some critical limitations like: number of variables used, complexity, accuracy, speed, hardware implementation, cost, tracking efficiency and so on.

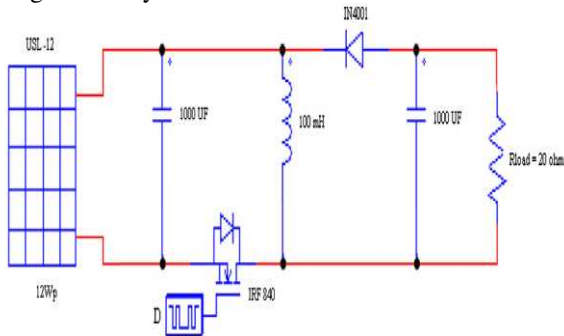

Fig. 2.2 Schematic of Buck- Boost Converter

B. System description

According to the maximum voltage produced by the PV panel is 0.8 (k1) times the open circuit voltage interrelated to that PV panel. Proposed a maximum power point algorithm based on short current and demonstrated that maximum current produced by the PV panel is 0.92 (k2) times the short circuit current of the PV panel.

$$P_{max} = V_{mpp} I_{mpp} = K_1 K_2 V_{oc} I_{sc} = 0.736 V_{oc} I_{sc} \quad (3)$$

III. PROPOSED METHOD

A. System Modelling

Current PV applications require different DC/DC converter topologies. Recently, a buck converter was chosen for DC Micro grids, distributed MPPT schemes, and stand-alone applications. Hence, in this study for the design and implementation of the proposed MPPT controller, the buck converter is considered because of its simplicity, and high efficiency. In spite of that, the same methodology described in this work can be extrapolated to another DC/DC converters, as boost, buck/boost, SEPIC, and Cúk, and it will be reported in future works. In the following, the nonlinear dynamic

model of the DC/DC converter employed in the MPPT system is presented in this section.

B. Power Converter Modelling

The power converter used in this study is presented in Fig. 3.1. This system is formed by the buck converter, and a capacitive filter C_{pv} . The average model of the system is represented by the following set of equations:

$$\begin{aligned} \dot{x}_1 &= \frac{1}{C_{pv}} x_2 u + \frac{1}{C_{pv}} i_{pv} \\ \dot{x}_2 &= -\frac{1}{L} x_3 + \frac{1}{L} x_1 u \\ \dot{x}_3 &= \frac{1}{C} x_2 - \frac{1}{C} i_o \end{aligned} \quad (4)$$

The photovoltaic current i_{pv} is generated by the PVM. The signal u is the control variable that represents the duty cycle for the switch Q_1 , and consequently, it has a limited operating range, $u \in [0, 1]$. Finally, in this model, an arbitrary load has been considered, which is characterized by its electrical properties $(v_o, i_o) = (x_4, g(x_4))$. In this case, a sector condition for the function g is only necessary in order to satisfy internal

Stability and to reject load variations, as described in detail through Proposition 1. Note that, the mathematical model shown in (2) presents nonlinear dynamics. Hence, conventional linear control techniques might result in a poor MPPT performance. Therefore, in further section, an input-output linearization technique with integral action in the tracking error, plus a feed forward action on i_{pv} is used to achieve the desired performance under sudden irradiation drops, set-point changes and load disturbances.

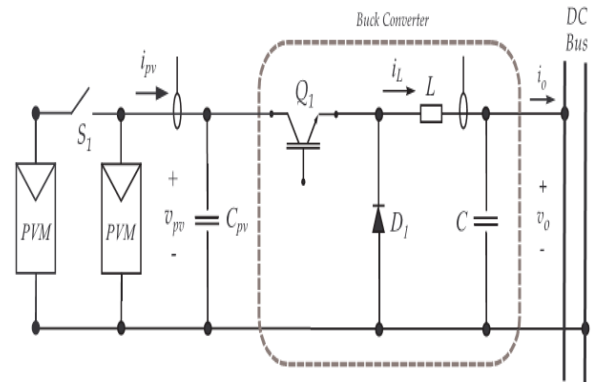

Fig 3.1 Circuit Diagram of Buck power converter as MPPT

C. MPPT Controller

In this section, the MPPT control strategy is derived based on the model of the DC/DC converter in (2) and an input-output linearized execution. Moreover, the proof of stability of the resulting zero dynamics, as one of the main results in this work, is studied in detail in this section.

Even though references almost input-output linearization (IOL) control have been offered in the literature of power electronics, only one reference about the implementation of an IOL controller for MPPT applications have been described so far. In that work, a boost converter was employed with a current oriented control perspective for MPPT applications, where the control law is dependent on the parameters of the PV array and power circuit.

D. Input-Output Linearizing State Feedback Control

If the voltage of the PVM is chosen as output $y = x_1$. The first derivative of the output is given by:

$$\dot{y} = -\frac{1}{C_{pv}} x_2 u + \frac{1}{C_{pv}} i_{pv} \quad (5)$$

Since the control signal u appears in the first derivative, this means that the nonlinear system presents an analogous degree $\rho = 1$ in \mathbb{R}^4 . As a consequence, two internal states are impalpable by the control action. However, in the following, internal stability is guaranteed for several load scenarios. Next, assuming that the state x_2 is available for feedback, it defines a linearizing control law as:

$$u = -\frac{1}{x_2} \sigma \quad (6)$$

Where σ is an auxiliary control law. The elements of the buck converter and its switching frequency must be selected in such way that it operates in a continuous-conduction mode. Thus, by substituting the control signal (3) in the first derivative (2), the following result is obtained:

$$C_{pv} \dot{y} = \sigma + i_{pv} \quad (7)$$

To provide robustness to the MPPT strategy, the auxiliary signal σ is constructed by a proportional-integral (PI) action with respect to the reference error in the PVM voltage, plus a feed forward term that cancels the input current i_{pv}

$$\sigma = C_{pv} \dot{y}^* + K_p (y^* - y) + K_i \int (y^* - y) dt - i_{pv} \quad (8)$$

Where y^* denotes the voltage reference. As a result, y^* will be chosen to guarantee the MPP in the PVM. By substituting (5) in (4), the tracking error dynamics are obtained.

$$\ddot{e} + \frac{K_p}{C_{pv}} \dot{e} + \frac{K_i}{C_{pv}} e = 0 \quad (9)$$

Where $e = y^* - y$. The Eq. (6) satisfies the following characteristic equation:

$$\lambda^2 + \frac{K_p}{C_{pv}} \lambda + \frac{K_i}{C_{pv}} = 0 \quad (10)$$

In this way, to guarantee the asymptotic convergence to the voltage reference $y \rightarrow y^*$, the error dynamics in (6) are assigned to the standard system.

$$\lambda^2 + 2\xi \omega_n \lambda + \omega_n^2 = 0 \quad (11)$$

Where ξ represents the damping factor, and ω_n the undamped natural frequency. Therefore, to ensure asymptotic stability, it is enough to choose two positive gains K_p and K_i , that achieve the desired transient response. Nevertheless, K_p and K_i have been defined such that the step response of the system behaves like a slightly under damped system, in order to remove transient oscillations in the PVM voltage (x_1) due to changing environmental conditions. For this purpose, the damping factor is chosen as $\xi = \frac{1}{\sqrt{2}}$, and the settling time (t_s) is considered equal to $t_s = 10T_{sw}$, where T_{sw} is the switching period. Thus, the PI controller's gains are chosen as:

$$K_p = \frac{4}{\omega_n} C_{pv} f_{sw} \quad \text{and} \quad K_i = \frac{\omega_n^2}{25} C_{pv} f_{sw}^2 \quad (12)$$

Where $f_{sw} = 1/T_{sw}$ represents the switching frequency. Now, by taking into account the voltage reference generation stage described in further section, for the controller implementation, it is assumed that the voltage reference is constant or gradually time-varying, i.e. $\dot{y}^* \approx 0$. In this way, from (5), the following auxiliary control law σ is considered in the experimental evaluation:

$$\sigma = K_p (y^* - y) + K_i \int (y^* - y) dt - i_{pv} \quad (13)$$

Hence, departing from (3) and (10), the resulting control algorithm does not depend on the parameters of the DC/DC converter or PV array parameters. Only K_p and K_i are determined as functions of the capacitor C_{pv} and frequency f_{sw} . In spite of that, during the implementation, only C_{pv} could have a parametric variation since f_{sw} is fixed. To evaluate the robustness, in the experimental results section, the effect on the closed-loop dynamic response under parametric uncertainty of the capacitor C_{pv} , is illustrated for all the experiments. Thus, by using (3) and (10), a voltage oriented controller insensitive to parametric uncertainty is obtained by this control strategy. A block diagram of this control strategy is presented in Fig. 3.2.

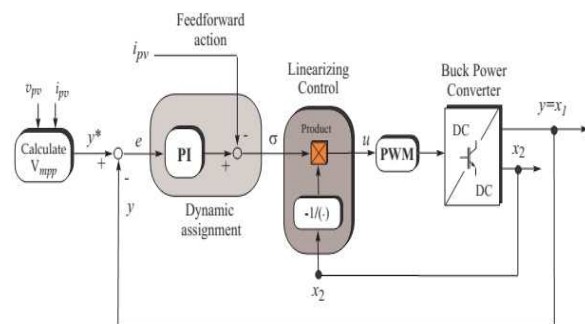

Fig 3.2 MPPT Control Strategy

Hence, the robustness to model parameters and DC bus voltage variations, is achieved at the price of three measurements for control. Voltage and current (v_{pv} , i_{pv}), and inductor current i_L . In addition, the MPPT is also independent from the rating power of the DC/DC converter, that mainly depends on the semiconductor and passive elements sizing and heat dissipation capabilities but not on the control philosophy. Finally, the MPPT control technique proposed in this paper is able to transfer the maximum energy to an unknown load by ensuring internal stability, as described.

E. Zero Dynamics

In this section, one of the main contributions of this paper is described, where the load of the DC/DC converter is extended further from a simple resistor or constant voltage source. In this way, an unknown load is considered. Nevertheless, internal stability for the unobservable dynamics is guaranteed for several loads conditions. With this aim, in order to characterize the zero dynamics, the state vector x is restricted to:

$$Z = \{x \in \mathbb{R}^3 \mid x_1 = 0\} \quad (14)$$

With $u = 0$, which leads to the following autonomous system for the DC/DC converter model in (2)

$$\begin{aligned} \dot{x}_2 &= -\frac{1}{L}x_2 \\ \dot{x}_3 &= \frac{1}{C}x_2 - \frac{1}{C}i_o \end{aligned} \quad (15)$$

By assuming that the load current i_o is a function of the state x_4 , i.e, $i_o = g(x_4)$, then the zero dynamics given by:

This result guarantees that the state variables x_2 and x_4 are bounded in spite of DC bus voltage variations; meanwhile the state variable x_1 follows asymptotically its voltage reference. Proposition 1

The dynamical system η has the origin as a unique and asymptotically stable equilibrium point if

$$g(0)=0; \mathbf{x}_2 g(\mathbf{x}_2) > 0; \quad (16)$$

Proof of Proposition:

First, by the property in (14), (0, 0) is the only equilibrium point of η , and the following quadratic energy function is proposed:

$$V(\mathbf{x}_2, \mathbf{x}_3) = \frac{1}{2} Lx_2^2 + \frac{1}{2} Cx_3^2 \quad (17)$$

By taking its derivative along the trajectories of the system, and by using the dynamic equations of η , it is obtained:

$$\dot{V}(\mathbf{x}_2, \mathbf{x}_3) = -x_2 g(\mathbf{x}_2) < 0 \quad (18)$$

Hence, the time derivative \dot{V} is negative definite $\forall x_4 \neq 0$, but other than that of x_2 . However, by LaSalle's Theorem, it can be concluded that the dynamical system η has an asymptotically stable equilibrium point (0, 0), because

$$x_2 = 0 \Rightarrow x_3 = 0$$

Therefore, the system η is minimum phase.

F. Voltage Reference Generation

Finally, to obtain the reference voltage y^* , different existing techniques can be considered. Recently, some techniques to lighten the reaction of partial shading. However, even if it could be possible to identify the global MPP, each module cannot be operated at its own MPP. Hence, distributed MPPT schemes are being proposed as solutions to partial shading and mismatching conditions, where the buck converter is suitable for series connection. However, the contribution of this paper is not directed towards a method to calculate the MPP. In fact, the control algorithm in this work is independent from the technique used to calculate the MPP. Hence, the simplest technique to calculate the voltage associated to the MPP is known as Fractional Method.

This technique is adopted here for its simplicity, which is based on the fact that the MPP voltage is a percentage of the open-circuit voltage V_{oc} , i.e.,

$$y^* \approx 0.8V_{oc} \quad (19)$$

Finally, note that the open-circuit voltage is periodically updated in our implementation, and maintained as a constant value after each measurement.

IV. SIMULATION AND RESULTS

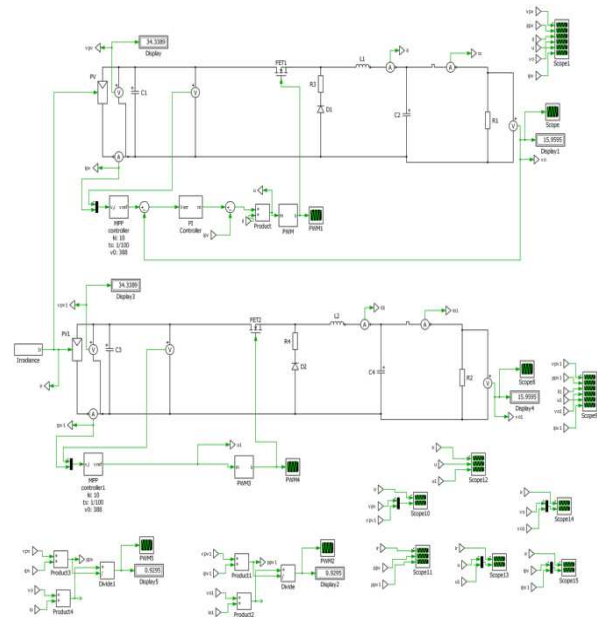

Fig 4.1 Simulation Diagram of the Proposed Converter

With the aim of verify the robustness of the proposed converter a validation pattern is proposed which has a change in solar irradiance at an interval of time, the experiment was validated with the uniform irradiance to the traditional converters with the purpose of authenticate the act of the proposed voltage linearizer a modified approach in regulating the voltage response of the traditional MPPT systems a simulation model of the system is designed using plexim, the results of the linearizer and the traditional mode is compared to prove the internal stability. The estimation and the experimental study is done to identify the variations of the controller when the irradiation variation happens, the following results in this chapter shows the stability of the converter under various loading and irradiation conditions.

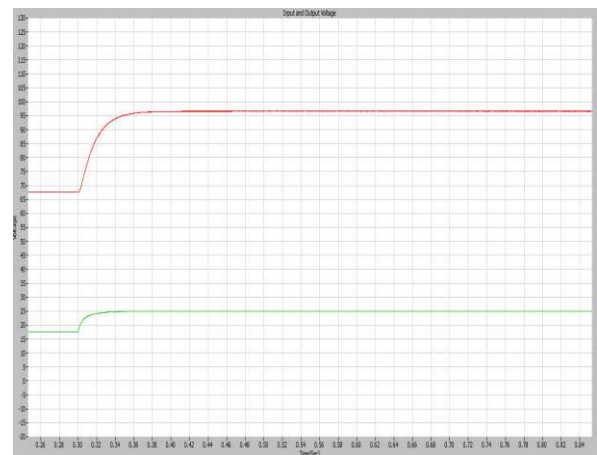

Fig. 4.2 Input and Output Voltages

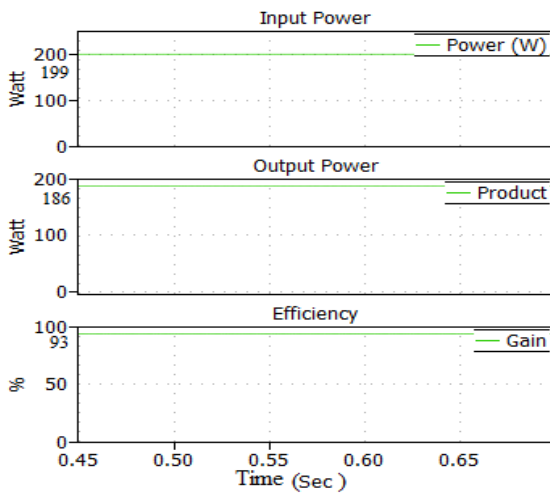

Fig. 4.3 Input, Output Power and Efficiency

V. CONCLUSION

Subsequently MPPT algorithms used in PV systems are one of the most important factors distressing the electrical efficiency of system, since to maintain the efficiency of the under various environmental conditions, this project brings a robust input-output linearization controller as maximum power point tracking (MPPT) technique in a photovoltaic (PV) buck DC-DC converter. Due to the simpler control structure that brings a cascaded control which integrates the traditional MPPT systems with the closed loop control which is able to track irradiance changes. For the meantime, the internal stability of the overall closed loop system is assured for different load setups. The MPPT control system is validated through experimental results, where the closed-loop performance is evaluated under abrupt irradiance and set-point changes. The experimental results shows the MPPT system has a better stability and robustness over voltage control, that maintains the efficiency which makes the controller suitable for various DC applications that demand high efficiency.

systems which is used along with the existing MPPT strategies that reduces the voltage transitions during the sudden change of the solar power. The stability of the proposed system is better as compared to the traditional systems, as the solar panels exhibit a non-linear relationship between the voltage and the irradiance. Since a machine learning method would be an optimal choice which provides a better and enhanced reliability, the extension of this work can be done through the non-linearity approach through soft switching techniques that brings a better stability and reliability over voltage control under various solar operating conditions.

REFERENCES

[1] Abdelsalam AK, Massoud AM, Ahmed S, EnjetiPN(2011). High-performance adaptive perturb and observe MPPT technique for photovoltaic based microgrids. *IEEE Trans Power Electron*;4:26.
[2] Aganah KA, LeedyAW(2011).A constant voltage maximum power point tracking method for solar powered systems. In: *Proceedings of the IEEE 43rd south eastern symposium on system theory (SSST)*;pp. 125–30.

[3] Bazzi AM, KreinPT(2011). Concerning maximum power point tracking for photovoltaic optimization using ripple-based extremum seeking control. *IEEE Trans Power Electron*;26(6):1611–2.
[4] Bianconi E, Calvente J, Giral R, Mamarelis E, Petrone G, Ramos-Paja CA(2013), et al.Perturb andobserve MPPT algorithm with a current controller based on the sliding mode. *Int J Electr Power Energy Syst*;44(1):346–56.
[5] Brunton SL, Rowley CW, Kulkarni SR, Clarkson C(2010). Maximum power point tracking for photovoltaic optimization using ripple-based extremum seeking control. *IEEE Trans Power Electron*;25(10):2531–40.
[6] Coelho RF, Concer FM, Martins DC(2010). A simplified analysis of DC–DC converters applied as maximum power point tracker in photovoltaic systems. In: *2ndIEEE international symposium on power electronics for distributed generation systems*;, pp. 29–4.
[7] Enslin JHR, Wolf MS, Snyman DB, SwiegersW(1997). Integrated photovoltaic maximum power point tracking converter. *IEEE Trans Industr Electron*;44:769–73.
[8] EramT,Chapman PL(2007).Comparison of photovoltaic array maximum powerpoint tracking techniques. *IEEE Trans Energy Convers*;22:2.
[9] Hua C, Lin J, ShenC(1998), Implementation of a DSP-controlled photovoltaic system with peak power tracking. *IEEE Trans Industr Electron*;45(1):99–107.



J. Joan Vinith, currently pursuing his Master of Engineering in PSNA College of Engineering and Technology, Dindigul, Tamilnadu, India. He received the B.E degree in electrical engineering from the M.Kumarasamy College of Engineering, Karur in 2015..



R.M.Sekar, received the M.Tech degree in Power Electronics from VIT University, India, in 2004. He is currently working as an assistant professor in PSNA College of Engineering and technology, Dindigul, Tamilnadu, India in the Department of Electrical and Electronics Engineering. His research interests include multilevel inverters, alternative energy sources, energy conversion, power quality, active harmonic analysis and Facts devices analysis and control.