

Design and Development of Self-Governing Robotic Cart for Universal Applications

Dr.M.Karthik, K.Sudharshan, D.Subramani, S.Nivethitha

Abstract— In this paper, we describe a concept of designing a robot capable of pursuing a specific person with carrying person's luggage. The proposed system involves robotic cart which is able to track and follow the target in unstructured environments. This reduces the human efforts in domestic and industrial applications. A person following robot is desired in many applications. It uses a control system which can carry luggage as well as follow the target person. The follower robotic cart is proposed by interfacing the microcontroller with an ultrasonic sensor. Ultrasonic sensors are used to identify and follow the target person. The system is designed to provide a contactless transport along with the target person. The distance between the person and the robot is measured and the movement of the robot is decided by the inputs given to microcontroller by ultrasonic sensors mounted on servo motor which helps to drive the robot.

Index Terms— Carrying luggage, Microcontroller, Ultrasonic sensor.

I. INTRODUCTION

Conventional luggage carrying system or following system is both time consuming and labor intensive. At the same time it is an expensive process and slow. The proposed Automated System for luggage carrying system can provide those features needed to overcome the problems. The proposed system reduces the man power requirements by automatic systems. This robot will reduce the time delay and human efforts in luggage management. In order to solve this problem, robotics has better solutions. Robot assistance is proved to be always helpful for us. It is desired in many applications that the robot be able to track and follow the person. The robot should be able to track the movements of the person and follow him. The methods of following target person require ceaseless analysis of distance between the target person and the robot. The follower robot implemented using cameras has a problem in background/foreground separation. This slows operation of the robot. These systems are slow in analyzing complex situations. These sensors detect the path and follow it. Line follower robot needs a predefined path and thus it cannot be used in day to day life. These systems are unable to avoid the obstacles. To order to eliminate this problem, we decided to implement the system using ultrasonic sensor. Data received from ultrasonic sensor is processed by microcontroller and thus the movement of the cart is decided.

Dr.M.Karthik, Assistant Professor (Senior Grade), Department of Electrical and Electronics Engineering, Kongu Engineering College, Erode, Tamilnadu, India

Sudharshan K, Subramani D, Nivethitha S, Scholars, Department of Electrical and Electronics Engineering, Kongu Engineering College, Erode, Tamilnadu, India

II. PROPOSED METHODOLOGY AND MATERIALS

In Autonomous follower, the ultrasonic sensor module is the key element in target detection. The ultrasonic module consisting of a transmitter and receiver sections will detect the human presence. The robot will move forward, right or left in accordance with the detected human presence. Ultrasonic transmitter emitted an ultrasonic wave in one direction, and starts timing when it launched. Ultrasonic spread in the air, and would return immediately when it is hit by obstacles on the way. At last, the ultrasonic receiver would stop timing when it received the reflected wave. As Ultrasonic spread velocity is 340m / s in the air, based on the timer record t , we can calculate the distance (s) between the obstacle and transmitter, namely:

$$s = 340t / 2 \quad (1)$$

This is so-called time difference distance measurement principle the principle of ultrasonic distance measurement used the already-known air spreading velocity, measuring the time from launch to reflection when it encountered obstacle, and then calculate the distance between the transmitter and the obstacle according to the time and the velocity

Distance Measurement formula is expressed as:

$$L = CXT \quad (2)$$

In the formula, L is the measured distance, and C is the ultrasonic spreading velocity in air, also, T represents time (T is half the time value from transmitting to receiving). Thus, the principle of ultrasonic distance measurement is the same with radar. Here we used two ultrasonic sensor mounted on servo motor. We drive Servo motor to specific angular position based on motion of target or object. Angular position for servo motor is determined using two distances measured from both left and right ultrasonic mounted on servo motor. Then motors are triggered using motor driver module to follow the motion of target or object in the environment.

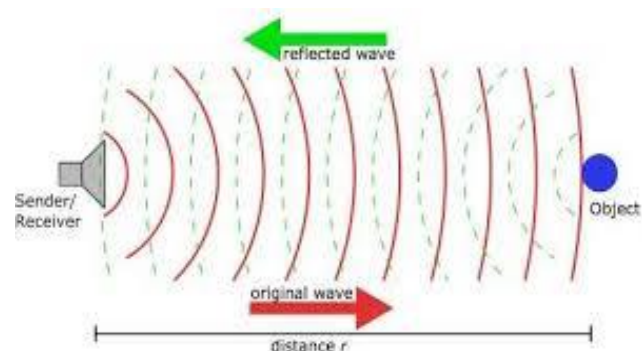

Fig.1.Ultrasonic Wave Propagation

A. Architecture

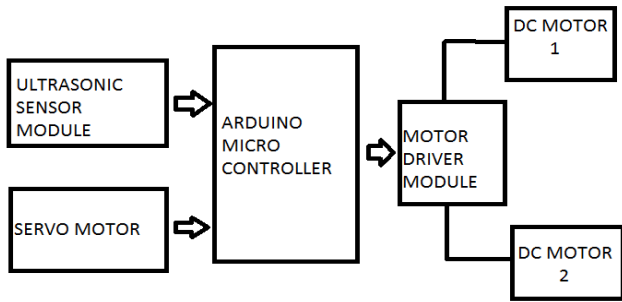

Fig.2.Architecture

System consists of couple of ultrasonic sensors at front, which is used to track target and avoid the collisions. These sensors are mounted on servomotor which is connected to Arduino Uno microcontroller via general purpose input output pins. System also comprises of motor driver which drives motors for locomotion of robot according to sensor value and angular position of servomotor. Refer Fig.2.

B. Process Flow

The flowchart of the overall system operation is as given below in fig.3. As soon as the system starts, initialize the hardware, servo motor is moved to preset threshold angular position. Initialization is a process of assigning the variables to the threshold distance value to be compared for movement of robot. After initialization assign echo and trigger pins for ultrasonic sensor. Activate the trigger for at least 20 milliseconds for all two ultrasonic sensors mounted on servomotor. Read Echo pin using timer and increment the counter value. Calculate or convert the obtained value in centimeter using a function. If left distance and right distance from both ultrasonic sensor is compared with threshold preset distance, then following condition are checked. If left distance greater than right distance, angle is incremented and if right distance greater than left distance, angle is decremented .so with this angle target tracking is done with appropriate firing of motor driver. If angle is less than 60 and not equal to 0, turns right. If angle is greater than 100 and not equal to 160, turns left .If angle is greater than 60 and less than 100, moves forward. So this process is repeated in loop for continuous operation of robot.

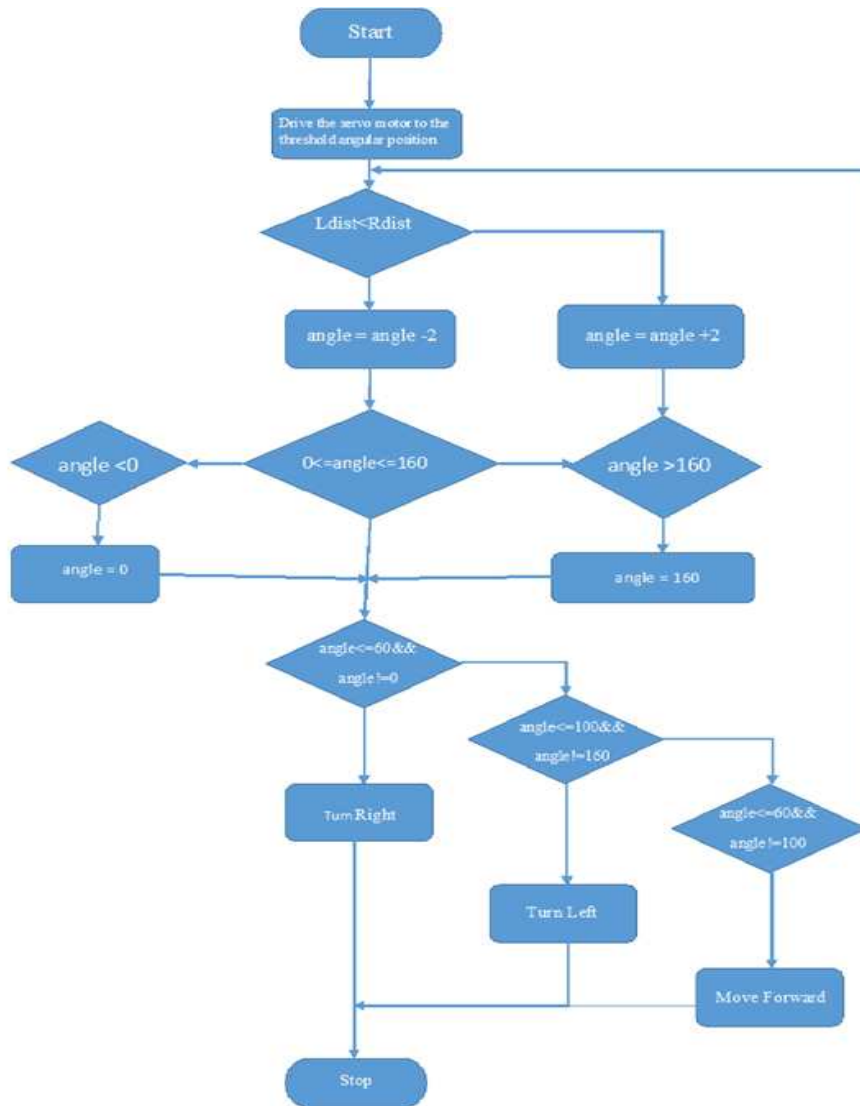

Fig.3. Flowchart of the proposed system operation

C. Sensor Platform

HCSR04 is used as ultrasonic ranging module. It has ranging distance of 2cm to 500cm. Its quiescent current is less than 2mA and its operates on 5V DC. Its effective angle is 15 degree. Ultrasonic sensor works on the principle of reflection. A short ultrasonic pulse is transmitted at one time pulse. The sensor receives the signal reflected by the object. The next pulse is not transmitted until the echo of previous pulse fades away. The cycle is less than 50ms. It is mainly used for distance measurement. The resolution of the ultrasonic sensor is 0.3cm. Therefore, ultrasonic sensor can be used to measure distance. HC-SR04 ultrasonic sensor consists of a transmitter, a receiver and a control module.



Fig.4.Ultrasonic Sensor

D. Motor Driver

The L298N Motor Driver module can be used with a variety of robot controllers. It is a powerful motor driver module with a heavy duty heat sink. It can drive motors from 5-35V at up to 2A peak. An on board 5V regulator can be used to power other robot's circuitry such as an Arduino microcontroller. It is a powerful *driver* capable of accepting standard TTL(Transistor Transistor Logic) logic levels and drive DC and stepping *motors*. Two enable inputs are used to enable or disable the device independently of the input signals. Inputs are given to IN1 and IN2 for motor 1, IN3 and IN4 for motor 2 and ENA, ENB are enable pins of motors. Two DC motors can be driven simultaneously in forward and reverse direction. The motor operation is controlled by logic inputs. Logic 01 and 10 will rotate the motor in clockwise and anticlockwise directions. The L293N basically drives two DC motors which are responsible for the movement of the cart in forward and reverse direction. The left and right direction movement is achieved by changing the speed of one motor. The cart turns in right direction if left motor speed in greater than right motor. Similarly, the cart turns in left direction if the right motor speed is greater than left motor

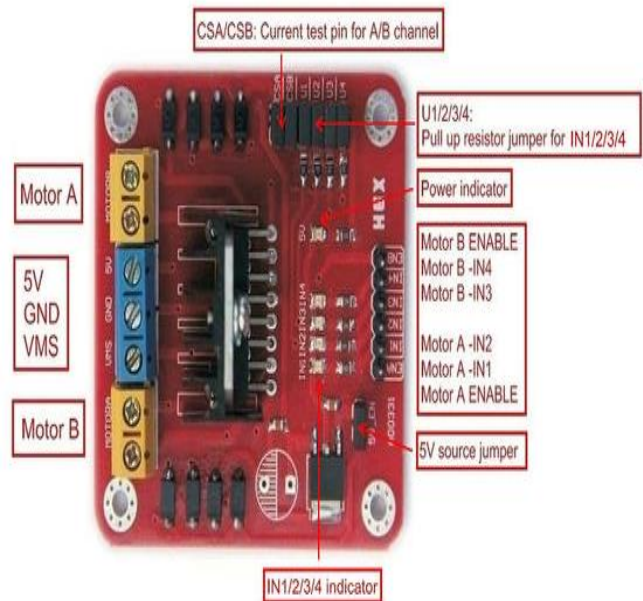

Fig.5. Motor Driver



Fig.6. Arduino UNO Microcontroller

Table. I L298N Motor Driver Truth Table

E. Arduino UNO Microcontroller

For this project Arduino UNO microcontroller, an Arduino component is used and it is shown in above Fig.6. Arduino is an open source computer tool that comes with both hardware and software platform. There are various components of Arduino in the market. The main purpose of the Arduino is to connect different electronic devices that can communicate with each other and perform various operations in the real world. The Arduino platform has a build-in integrated development environment called IDE. It helps to program any project with various other devices connected to it. It supports C and C++ programming language which are the basis of all other programming languages. We have selected this board because of the open source software that is related to the board and its flexibility for programming. It has 10 bit ADC which is essential to accept inputs from the sensors. As sensors provide the data in analog form. The data is converted into digital form using ADC. The operating frequency is high and the power consumption is less.

III. RESULT AND CONCLUSION

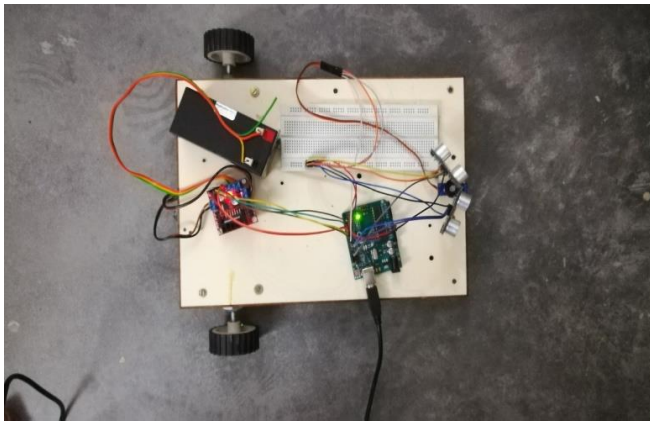

Fig.7. Final Prototype

The prototype developed almost had all the features of the proposed system. It has a target detection capability of around 1 meter and obstacle sensing power of around 30cm. The ultrasonic sensor uses a frequency of 40 kHz for its operation. Autonomous follower finds very useful applications in present day life. There are several chances for future enhancements and it can be successfully implemented at several places to reduce man power requirements, and to reduce time delay. The system provides a new approach in the field of robotics. This cart would be helpful in reducing work while performing certain task. The follower robotic cart has better scope in the near future

REFERENCES

- [1]Kwan-Hoon Kim; Jun-UkChu; Yun-Jung Lee “Steering-by-Tether and Modular Architecture for Human-Following Robot” SICE-ICASE, 2006. International Joint Conference Digital Object Identifier: 10.1109/SICE.2006.315704 Publication Year: 2006 , Page(s): 340 – 343
- [2]Woojin Chung ; Hoyeon Kim ; YoonkyuYoo ;Chang-bae Moon ; Jooyoung Park, Industrial Electronics, IEEE Transactions on Volume: 59 , Issue: 8 Digital Object Identifier : 10.1109/TIE.2011.2170389 Publication Year : 2012, Page(s) :3156 – 3166
- [3]Boris Sofman, Ellie Lin Ratliff, J. Andrew (Drew) Bagnell, John Cole, Nicolas Vandapel and Anthony (Tony) Stentz " Improving Robot Navigation Through Self-Supervised Online Learning," Journal of Field Robotics, Vol. 23, No. 12, December, 2006.
- [4]OnofrioGigliotta, Massimiliano Caretti, SolaimanShokur, Stefano Nolfi, “Toward a Person-Follower Robot”, IEEE Robotics and Automation Letters Vol. 2, Issue: 1, October, 2011.
- [5]Guanglong Du, Ping Zhang, Xin Liu “Marker less Human– Manipulator Interface Using Leap Motion with Interval Kalman Filter and Improved Particle Filter” IEEE Transactions on Industrial Informatics Vol. 12, Issue: 2, November, 2016.
- [6]Thomas Fulhammer, RareşAmbruş, Chris Burbridge “Autonomous Learning of Object Models on a Mobile Robot” IEEE Robotics and Automation Letters Vol 2, Issue: 1, Jan. 2017.
- [7]Mustafa Engin, DilsadEngin “Path Planning of Line follower Robot” Education and Research Conference, 2012.

Dr.M.Karthik, Assistant Professor (Senior Grade) Department of Electrical and Electronics Engineering Kongu Engineering College, Erode, Tamil Nadu, India

Sudharshan K, Scholars, Department of Electrical and Electronics EngineeringKongu Engineering College, Erode, Tamil Nadu, India

Subramani D, Scholars, Department of Electrical and Electronics Engineering Kongu Engineering College, Erode, Tamil Nadu, India

Nivethitha S, Scholars, Department of Electrical and Electronics EngineeringKongu Engineering College, Erode, Tamil Nadu, India