

# Design of Electric Vehicle

Kusum<sup>1</sup>, Chetan Parveer<sup>2</sup>

<sup>1</sup>Department of EE, CBS Group of Institution, Jhajjar, Haryana, India

<sup>2</sup>Assistant Professor, Department of EE, CBS Group of Institution, Jhajjar, Haryana, India

**Abstract**— The aim of this thesis work 'Design of electric vehicle including different power train components' is to design an energy model of electric vehicle including different power train components with the application of a design and simulation tool, which in this thesis work would be MATLAB Simulink software. With this design and simulation, we expect to find the energy consumption by a vehicle by virtue of different types of forces acting on vehicle when subjected to different standard driving cycles. This work also includes a survey of different vehicles which runs on electric propulsion either only or in assisted mode in the present market.

**Keywords**— Design, Simulation, Electric Vehicles, Dynamics, Electrochemical cell, Vehicle Energy Modelling, MATAB, Simulink, Driving Cycles, State of Charge, Energy, Voltage, Power, Lithium Ion Batteries, Aerodynamic Drag, C-Rate.

## I. INTRODUCTION

The nature of the fossil fuel, as the name indicate, 'Fossil',

which takes millions of years to get replenished in abundance. Natural phenomenon such as volcanic aerosol and anthropogenic economic activities has been seen as significant contributors to temperature rise over past years, apparently leading to temperature rise leading to glacier meltdown. (1) (2). The rate of consumption of the fuel is just making its way higher than the rate of productions, which inevitably will reach on a point where it will be absolutely exhausted with no more fossil fuels to satire the demand. Imagine life with mobile phones, but without any electricity to charge it, seems like dark ages, not a pretty picture to imagine. Other prominent concern related to the exhaustible use of fossil fuel is environmental issues. Impact of carbon di oxide gas (CO<sub>2</sub>) on the environment is not new to be known. It has been first theorized by noble prize laureate Svante Arrhenius back in 1896. However, the emission of the CO<sub>2</sub> can be divided majorly into two causes: Natural Phenomena and Anthropogenic.

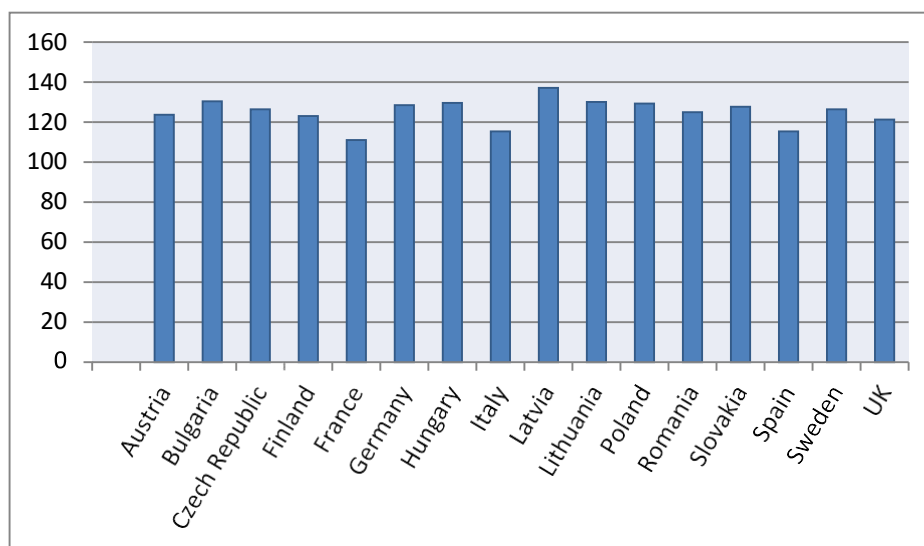

Fig.1: CO<sub>2</sub> emission in 2015

The problems just do not persist with the exhaustible nature of the hydrocarbons and environment. 'Oil' in this contemporary world scenario is not just an energy resource but also heavily influence the international politics and policies of nations. Different war conflicts and wars are waged to acquire the oil. New family of storage devices advanced electronic drives, fabrication of sophisticated

semiconductor materials, fabrication material, ultra-capacitors have played their major part in bringing back the trend of EVs with much more economy introduced in it. (1)With the current trend and peer pressure from the perspective of Environment, limited resource, and political interventions, vigorous researches are done through which lead to the advancement of existing technology. Intense

research and development is being carried out in order to develop new concepts, low cost, more reliability of hybrid power trains. As it can be seen as future of transportation, almost all major automobile manufacturers from all across the world are jumped into the market of EV, HEV and

FCEV . ‘Prius’ from Toyota, to name few available models. This competition has led to the creation of such cars which are economically viable and are being used now. Although, there are a lot of scope in the improvement of storage technology, which will open new doors for EVs.

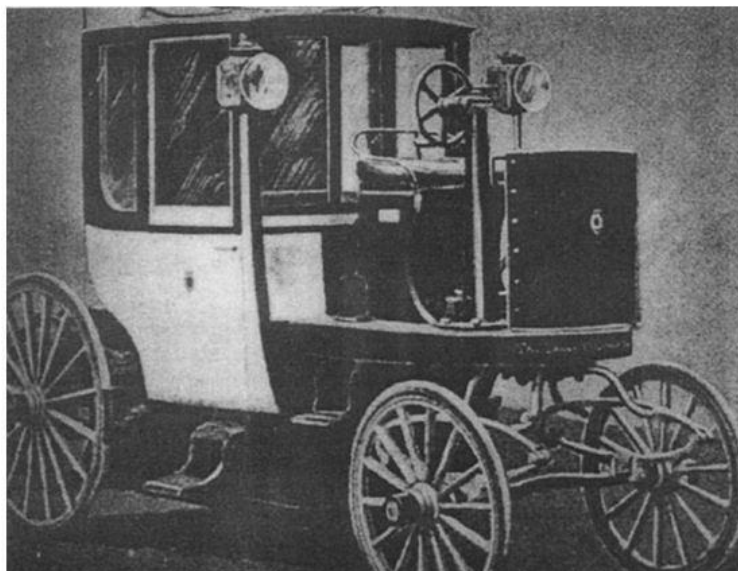
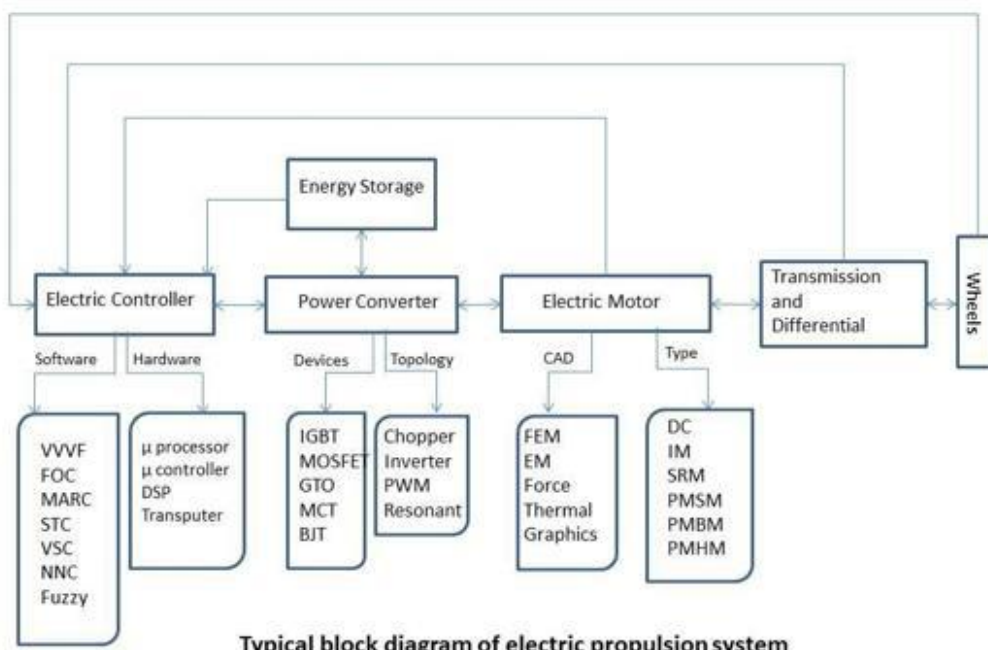

Fig.2: London electric cab company's taxi

Since BEV's is now being totally dependent of the electrical storage technology and will improve as storage and energy density will improve. Nowadays, Hybrid Electric vehicles are in trend. Hybrid vehicles. As per proposed by the Technical Committee 69 (Electric Road Vehicles), International Electro technical

Commission. "A hybrid road vehicle is one in which propulsion energy, during specified operational missions, is available from two or more kinds or types of energy stores, sources, or converter. Electric Propulsion



Typical block diagram of electric propulsion system

Fig.3: Representation of electric propulsion systems (4)

Electrical machines can be classified mainly into two

groups depending upon nature of electricity employed, DC

machine and AC machine. Both family of machines have their pros and cons, and found their application according to the load requirement. DC machines were incorporated in the 1980's decade due to its torque to load characteristics and controllability. In spite of such fine traits, DC machine are no longer being preferred due its size and maintenance requirement. Now a day, latest vehicles manufacturers are employing AC and brushless motors, including Induction Motors, Switched Reluctance Motor and Permanent Magnet Motors. This chapter aims to render a brief overview of electrical machines.

**DC Machine:** The electrical machine which uses the direct current as power input (motoring mode) and generating direct current (generation mode) are termed as DC machine. DC machines consists of two set of windings, on the rotor (rotating body mounted on shaft) and stator (stationary part which holds current carrying conductive wiring in order to cause the interaction between two field fluxes, resulting in torque generation producing necessary torque to overcome the inertia and friction. Simply put, force (F) experienced by any current carrying conductor of length (L) in the magnetic field density (B) is,

$$F = B \times I \times L \tag{1.1}$$

And when the current carrying conductor is in coil shape then, Torque (T) produced will be,

$$T = B \times I \times L \times \cos(\alpha) \tag{1.2}$$

$\alpha$  is angle between the coil plane and magnetic field (B).  
(4)

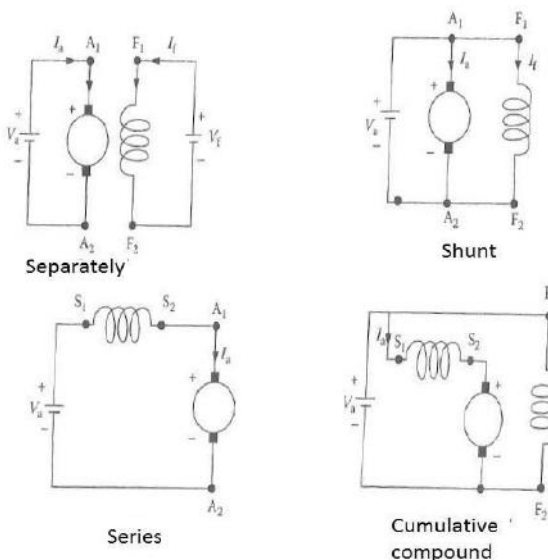
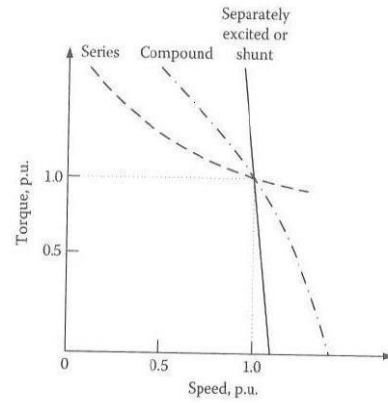

Fig.4: Different Schemes of stator field Winding



Torque vs. Speed Characteristics of different excitations

Fig.5: Torque vs Speed characteristics for DC machine

As it goes without saying all the topologies have its own advantage and drawbacks, and their application depends upon the load requirement as well. Typical torque- speed characteristics of the DC machines are mentioned as following.

In separately excited DC machine, it is easy to control field and armature voltage independently. Whereas, in shunt winding, which has same speed torque characteristics as separately excited machine, controlling is possible only when using inserting resistance in the circuit. However, it is an inefficient method due to the presence of the resistance in the circuit. But, if we replace the mentioned resistance in circuit by the power electronic devices (DC-DC converter) we can actively control production of proper armature and field voltage. (4)

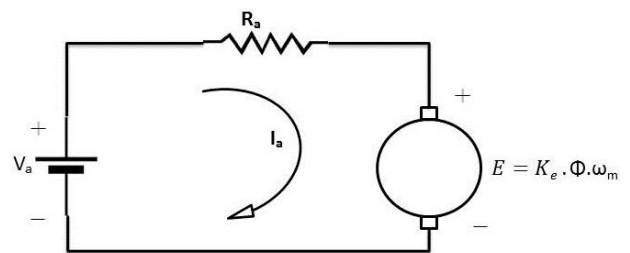

Equivalent circuit of the armature circuit DC motor

Fig.6: Equivalent DC Armature circuit

Basic equations of DC machines are as follows;

$$V_a = E + R_a \cdot I_a \tag{1.3}$$

$$E = K_e \cdot \Phi \cdot \omega_m \tag{1.4}$$

$$T = K_e \cdot \Phi \cdot I_a \tag{1.5}$$

Where,

$V_a$  = DC supply voltage (volts);  $\phi$  = flux per pole (webers);

$E$  = emf(volts),

$T$  = torque (N m);  $R_a$  = armature resistance(ohms);  $I_a$  = armature current(amps);

$\omega_m$  = armature speed (rad/s);  $K_e$  = constant.

The PM machines now a days are being preferred in the hybrid and electrical vehicles by the manufacturers since it has significant advantages over the conventional machines such as IM and DC machine, or Synchronous machines. Since, we already know that using excitation winding in machine always comes with the *excitation penalty* (8). The initial cost of the PM machines can be high but when we talk about the small motors for vehicular application, using of excitation winding can be complex and undergo losses. In addition to this, the field winding's current will lead to the deterioration of the winding which means increase of maintenance cost. Also, absence of excitation winding facilitates compact arrangement of the PM machines in the vehicle. On the other hand for the heavier machines excitation penalty is more economical as compared to the initial cost of PM machine. (8)

Discussion of PM machines is incomplete without discussing permanent magnets incorporated in PM machines. The main purpose of permanent magnet is to provide constant *mmf*, as a constant current source (8). The magnetic flux density remains constant as long as operating point is under the linear region, but as soon as operating point goes beyond, *knee-point* ( $B_d$ ) of the characteristics, some of the characteristic is lost permanently. When the demagnetizing field is removed beyond the limit, new characteristic will exist but lesser than last characteristics. But most PMs are designed to withstand considerable magnitude of current (up to 2-4 times the rated current). Some of the permanent magnets are enlisted and discussed below;

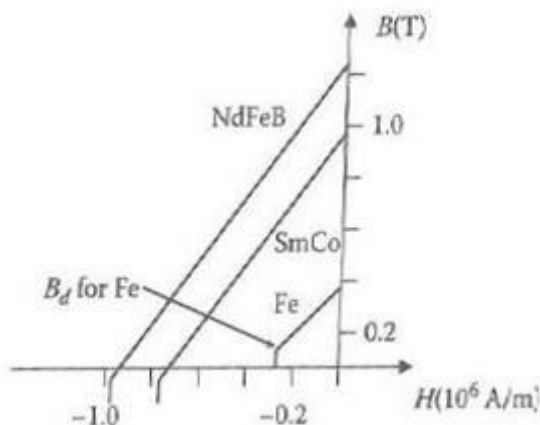

Characteristics of discussed permanent magnets

Fig.7: BH curve of permanent magnets

Simply put, PM synchronous motor is a synchronous motor which produces sinusoidal *mmf*, voltage and current provided by the permanent magnets. PMs used in PMSM motor ensure high flux density in air gap consequently increasing power density and torque to inertia ratio. Due to PMSM's fast response, high power density, and high efficiency it found its application in high performance

control application such as robotics and aerospace applications. The PMSM is fed from supply via power electronic converters with its smooth torque operation depends upon the shaping of current waveform. Field weakening mode is possible in PMSM by applying stator flux opposite to rotor flux. The speed is limited because of current rating, back-emf and maximum output of inverter. Although, PMSM and IM have good torque response but slip speed calculation makes IM more complex than that of PMSM. According to construction, PMSM has lower inertia due to absence of heavy rotor cage as in IM. Both IM and PMSM have limited field weakening range, a limitation.

PMSM has a higher temperature and load sensitivity which is the major drawback of PMSM, therefore, PMSMs are typically limited to low or medium power applications, however some of the high-power applications are employing PMSM.

PMSM has two main sections, rotor and stator, like in all rotating machines. Stator is incorporated with three phase sinusoidally distributed copper winding similar to AC machines winding. On the other hand, Rotor, does not have any winding but permanent magnets are settled over the rotor instead. The three phase balanced supply is provided to the stator winding which in turn establishes a rotating *mmf* of constant amplitude in the air gap. The stator current is regulated by the position feedback of rotor in order to maintain the frequency in synchronism to the rotor. The interaction of these stator and rotor fields results in the torque development on the rotor. (8)

The PMSMs can be classified on the position and shape of the magnets on/in rotor. Illustrative figure of the PMSM types are provided below;

a) Face Mounted      b) Inset      c) Interior

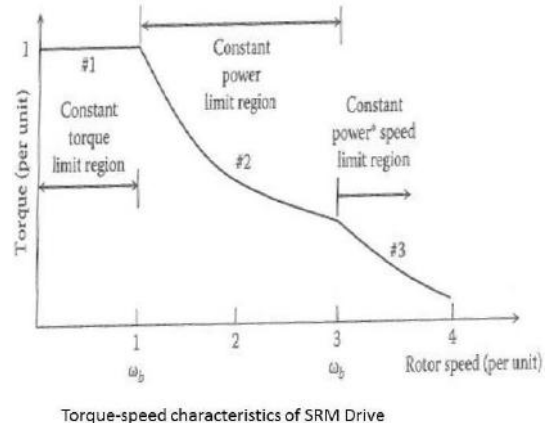

Fig.8:

Face mounted, and insets are also called surface-mount PMSMs. In inset the magnets are inside the rotor surface but exposed to air gap whereas in face mounted magnets

are protruding. The magnets are attached to rotor by the help of epoxy glue. It implies that the ability to perform surface- mount PMSM during operation depends upon the adhesiveness of epoxy glue. But these types of PMSMs are easier and simpler to construct. In contrast to them, in interior PMSM, magnets are actually buried inside the rotor, thus mechanical strength is higher as compared to the previous ones. However this technology is costly and complicated. (8)

## II. VEHICLE DYNAMICS

Vehicle design’s fundamentals are a direct implementation of Newton’s second law of motion, which relates force and acceleration. The acceleration of vehicle is caused by the fact of presence of non-zero resultant force. This force to move the vehicle forward comes from the propulsion unit overcoming the resisting force imposed by gravity, and air and tire resistance. The road and aerodynamic condition along with power available from traction unit determines the acceleration and speed of the vehicle. In this chapter we will get into basic governing factors affecting the design of the vehicle focusing on electric.

The force from the propulsion unit is known as the tractive force. Once the force required is known, energy and power consumption can be calculated.

### Centre of Gravity

According to newton’s second law of motion,

$$\sum F_i = m \times a; \tag{4.1}$$

Where,  $F_i$  = net force,  $m$  = mass,  $a$  = acceleration.  
 As a complex conjunction of subsystems, there exist different individual masses at several points of contact of the vehicle with reference to outside world leading to be a bit complex task to analyze and calculate forces at each point of mass’ contacts. Thus, in order to simplify this problem, we consider one location where all these points will merge and net force due to gravity can be realized. This location is known as *Centre of gravity* (COG) of the vehicle. For the calculation purpose, we shall consider vehicle to be a particle mass concentrated at the COG.

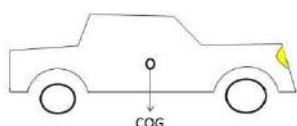

Fig.9: Center of Gravity

The motion of particle is defined by *acceleration* and *velocity* characteristics. let  $x$ , be the distance travelled by the particle and  $v$  be the velocity and  $a$  be the acceleration of the particle then the mathematical relation in these quantities are as follows,

$$\vec{v} = \vec{dx}/dt \tag{4.2}$$

$$\vec{a} = d\vec{v}/dt \tag{4.3}$$

The input power  $P$  for the force  $F$ , to the particle mass is,

$$P = \vec{F} \cdot \vec{v} = |\vec{F}| |\vec{v}| \cos\theta \tag{4.4}$$

Where,  $\theta$  is angle between  $F$  and  $v$ .

Torque  $T$  on the rigid body rotating about a fixed axis,

$$T = J \alpha; \tag{4.5}$$

Where,  $J$  = polar moment of inertia of the rigid body

$\alpha$  = angular acceleration (rad/  $s^2$ )

$$\text{Also, } \alpha = d \omega /dt \tag{4.6}$$

$$\omega = d\theta/dt \tag{4.7}$$

Where,  $\omega$  = angular speed (rad / sec)

$\theta$  = angular displacement.

The relation between power input and torque input is important and is given below,

$$P = T \times \omega \tag{4.8}$$

### Vehicle kinetics

The propulsion unit generates and exerts the *traction force* to the wheels to provide motion to the vehicle. In order to move vehicle, tractive force must overcome the opposing force acting on the vehicle. This opposing force is known as *road load force*,  $F_{RL} = F_{GxT} + F_{ROLL} + F_{AD}$ ; (4.9)

Where,  $F_{GxT}$  = Gravitational force,

$F_{ROLL}$  = Rolling resistance,

$F_{AD}$  = Aerodynamic drag force,

$xT$  is tangential direction on the roadway.

We will discuss these terms and, their cause and effect on the vehicle motion.

### Force due to gravity

The force on vehicle due to gravity is a function of slope of the road, the mathematical relation is given as follows,  $F_{GxT} = m g \sin \beta$ ;

Where,

$m$  = mass of the vehicle,

$g$  = acceleration due to gravity,

$\beta$  = slope angle (grade angle) with respect to horizon.

## III. MODELLING AND SIMULATION

In this chapter we will discuss and present the *Simulink* modelling of the electric vehicle with different powertrain.

For modelling of simulation vehicle MATLAB and *Simulink*<sup>TM</sup> (*Simscape*) from MATLAB is being used, due to its wide presence and easy to understand modelling technique. The model being discussed below consists of

three major components: Power Sources, Electromechanical device and loads by the virtue of vehicle motion in an open environment. The modelling does have assumptions in order to keep work easy and not complicated to understand for a layman. Due to assumptions, the accuracy of the model is affected, but it will provide base to idea being discussed in this thesis work.

The following assumptions are being taken under consideration

- Vehicle is moving with certain velocity according to standard drive cycle.
- Vehicle’s operation weather is constant at all instants during simulation.
- Batteries initially have finite state of charge.
- Using predefined standard drive cycles to assess the results.

With the start of the simulation, we will define some inputs in the *MATLAB Editor*. These values are being considered in accordance to *Nissan Leaf*. This model also allows us to observe range and power it can be taken out of any other vehicle model, once all the parameters are known. Following is the screenshot of the *MATLAB* editor, with the details mention as the comment in the editor itself due as it is convenient.

The study of the model is in accordance to variation in *velocity-time* profile (drive cycles) and *slope/s*. During drive cycles, the vehicle undergoes transiency due to start, stop, acceleration, braking. Thus, with drawing power and energy

from the battery packs in order to overcome the resistance offered by the vehicle. In addition to it, different power electronic converters such as DC/DC bidirectional inverter and DC/AC converters are used in series with electric machine. All these above mentioned converter components come with their own efficiencies. Due to these efficiencies, extra energies have to be extracted from the batteries in addition to required energy to overcome vehicle road load. These efficiencies are also being modelled in this chapter. Overall energy model of the electric vehicle:

With respect to following screenshot given below, the energy consumption of the vehicle from each of the individual energy consumption mentioned previous in the chapter is being added in order to give a output in the terms of the power required by the vehicle to complete different driving cycles our vehicle would be subjected to. Please note that this power consumption is just the result of the vehicle dynamics and not include *auxiliary* power consumptions, such as heating, air conditioning, and other amenities.

**Efficiency Modelling:**

This section of current chapter will bring some light on the modelling of different components incorporated in the drive train. These components facilitate power flow from the source, i.e. Electro-chemical batteries to the load, i.e. due to vehicle dynamics and auxiliary power consumptions.

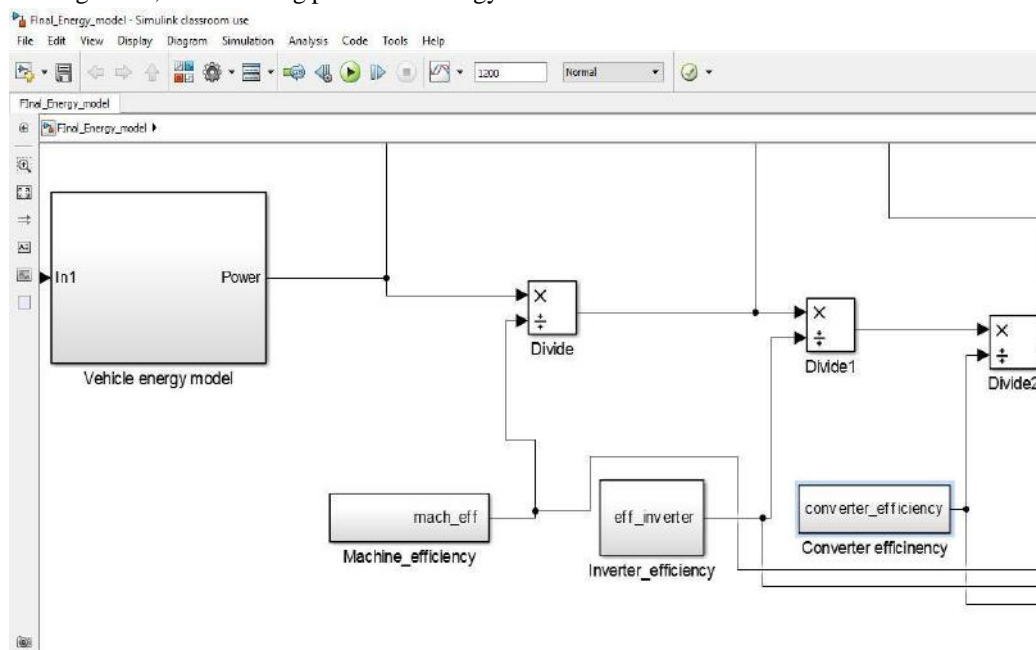

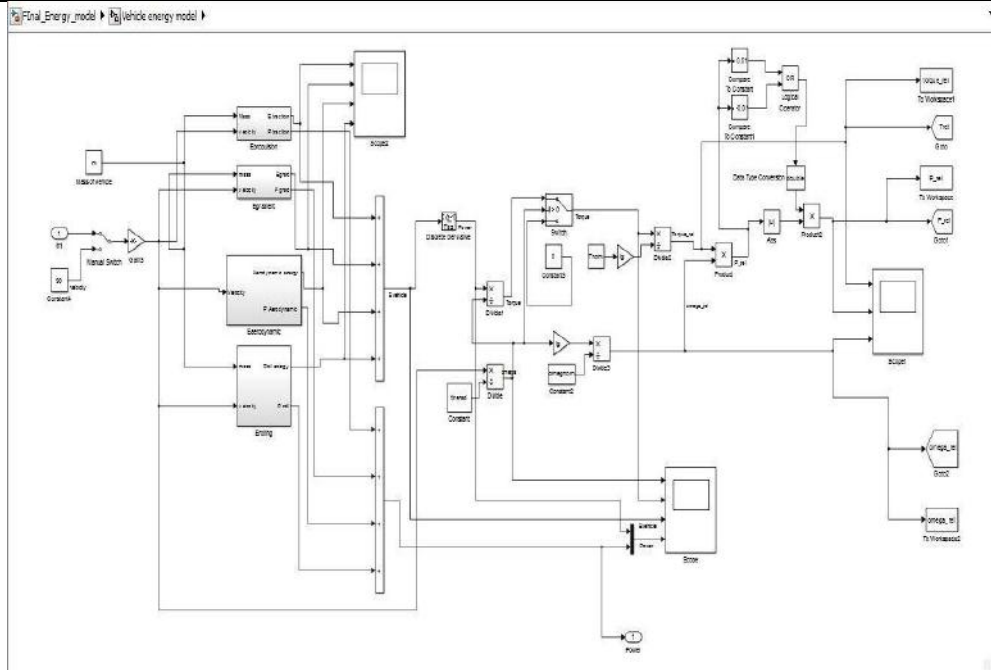

Fig.11: Model to estimate aggregate energy required

**Machine Efficiency**

Machines are electromechanical device, which are meant to provide interface between mechanical and electrical parameters. Mechanical input can be torque, force, speed and the output can be current, power, and vice versa. Ideally

machines have no losses, but in real case, there are different power losses due to different factors such as mechanical and electrical. Thus this loss can be measured by the mathematical relation in between machine’s output over input. (37)

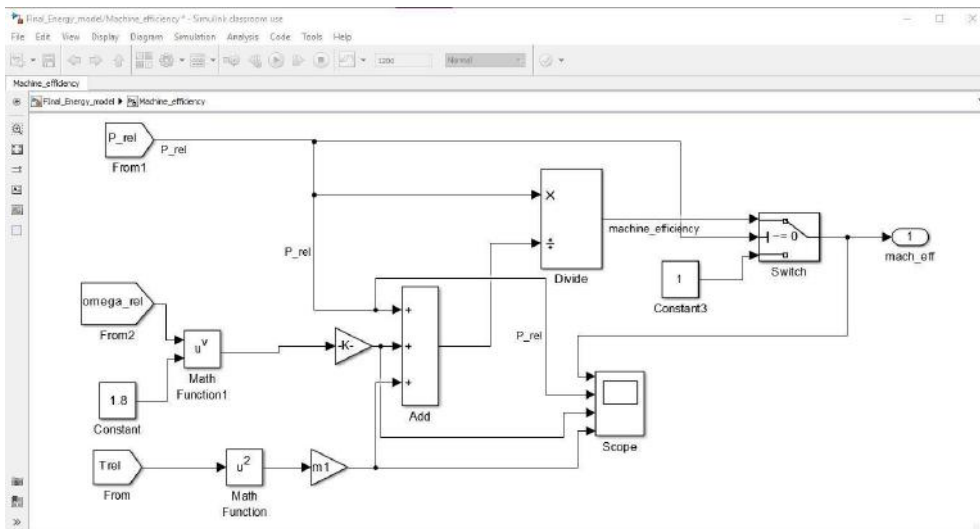

Fig.12: Machine's efficiency model

**Inverter Efficiency:**

One of two primary types of power electronic device’s application used in this model is inverter. Inverters are the devices which are responsible for conversion of direct current supply to three phase currents or vice versa by the means of intelligent switching of power electronic devices. There are different topologies and different scheme of switching schemes of inverters. Topologies and switching schemes are vast and requires whole

discussion over that, thus we are limiting the work to calculate the efficiency of the inverters being used, in general. Since, this modelling is to demonstrate energy consumption and comparison for different parametric changes in the vehicle loads, therefore, I am using a general mathematical relation for efficiency being mentioned during lectures. It greatly simplifies the model itself and easy to understand. (37)

$$\eta_{inverter} = \frac{P_{rel}}{i_1 * P_{rel} + i_2}$$

Where,  
 $\eta_{inve}$  = Efficiency of inverter,

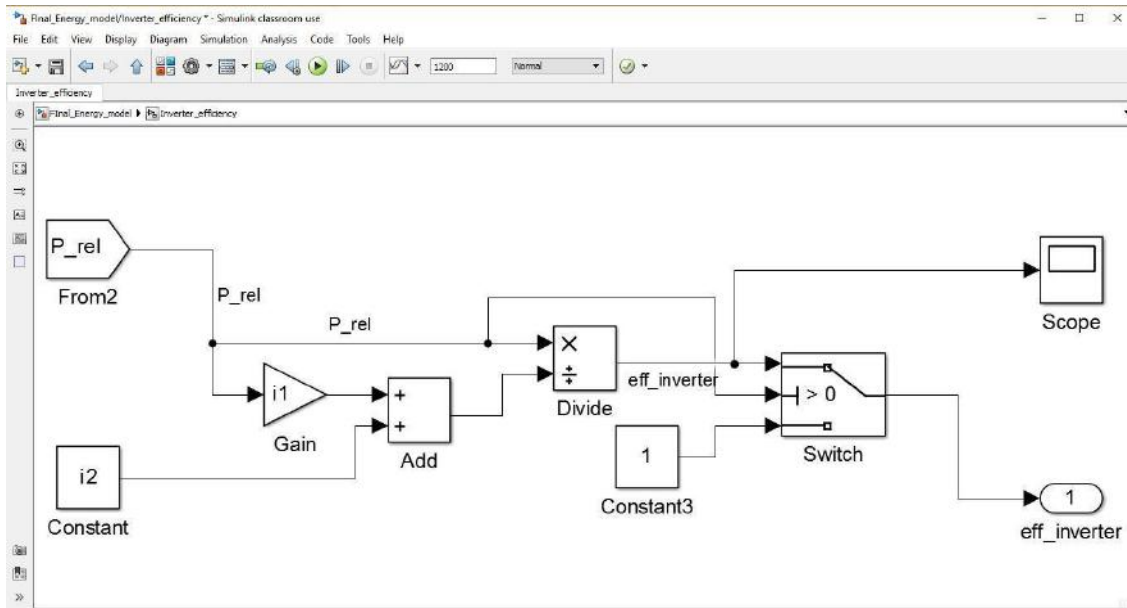

Fig.13: Inverter's efficiency model

**Converter efficiency:**

Converter or DC/DC converter is a device which alters the voltage level into different output. Usually rated voltage of electrical machine is different from that of battery terminal voltage. Also, ideal battery source experiences drop of voltage, depending on different parameters such as Battery's State of Health (SOH), lifetime, SOC, etc. (37)These effects have already been discussed during previous chapters in this work.

The mathematical model used for the *Simulink* model is as follows,

Where, = efficiency of DC/DC converter

$C_1 = 1.02$  (empirical value)

$C_2 = 0.005$  (empirical value) (37)

$$\eta_{converter} = \frac{P_{rel}}{c_1 * P_{rel} + c_2}$$

(6.4)

Once we get the efficiency from each component as above, we can calculate the actual energy (current) withdrawn from the battery source and thus we can know the actual SOC of the vehicle model.

**SIMSCAPE (Battery and controlled current source)**

In this chapter, a model has been worked out which includes the electrochemical battery source block from the *Simpowersystem*. We can choose any battery predefined in the block, such as Lead Acid, Ni-based batteries, Lithium-ion batteries (38). In this model, I have considered Lithium-ion battery model (used in Chevrolet Leaf), due to its scope in modern applications in terms of energy density, lifetime and flat profile of discharge. The *controlled current source* block is being used here to account the variation of load. This is being controlled by the current input. In this case, our input current is the result of the varying power requirement by the vehicle during different driving cycles. The screenshot of the *Simscape* model is mentioned down below,

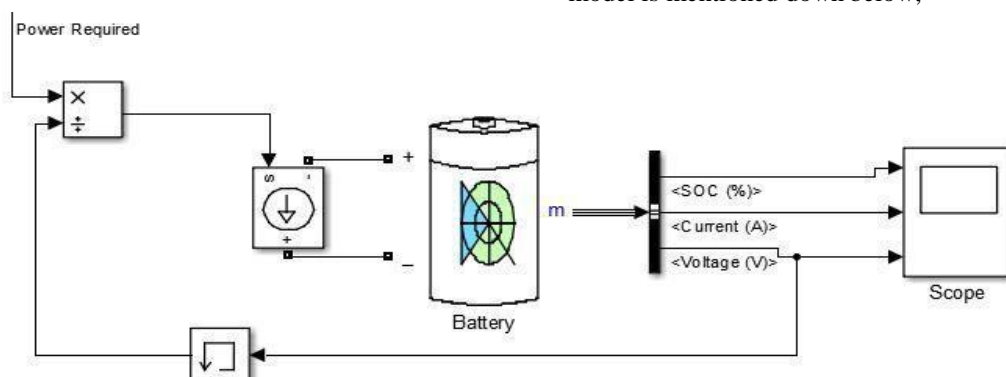

Fig.14: SIMSCAPE battery and Controlled Current source block



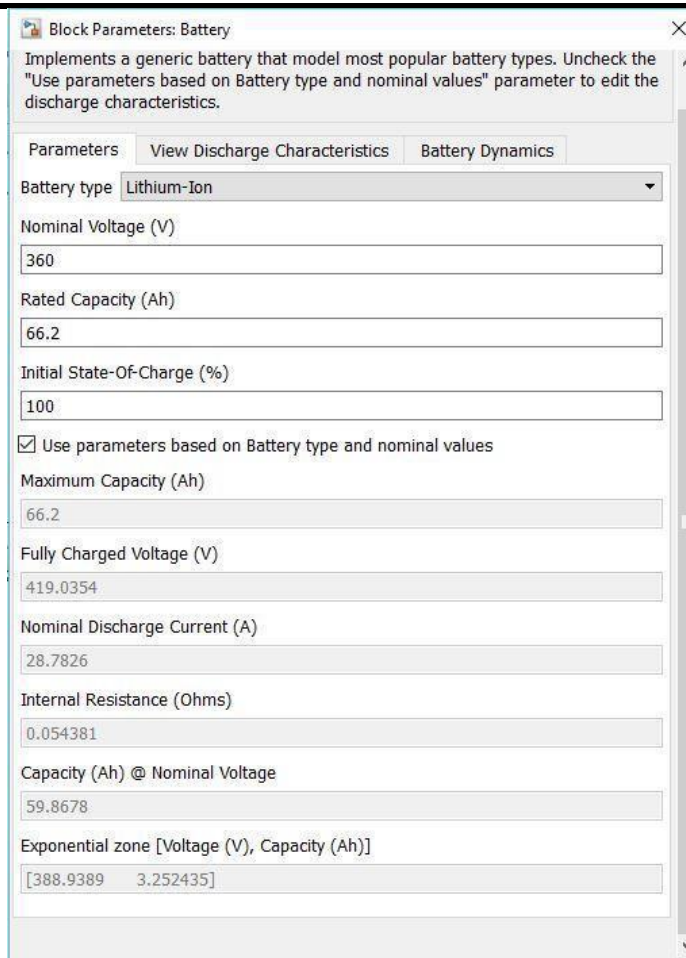

Fig.15: Battery parameters in accordance to light electric vehicle (Leaf)

**Observations**

In this section we will observe, energy consumed by the vehicle, State of Charge (SOC) remaining, and their comparison. With these observations we can observe how energy requirement varies with different profile of driving cycle along with the slope variation. We can also observe depletion of the battery during the standard and custom driving cycles, in the terms of SOC remaining at the end of

each driving cycle.

**IV. TOTAL ENERGY CONSUMED**

The scope’s graphs shown below are the total energy consumed by the vehicle model during the different driving cycles. We can notice different curves in graphs, they belong to different subjected slopes on the vehicle.

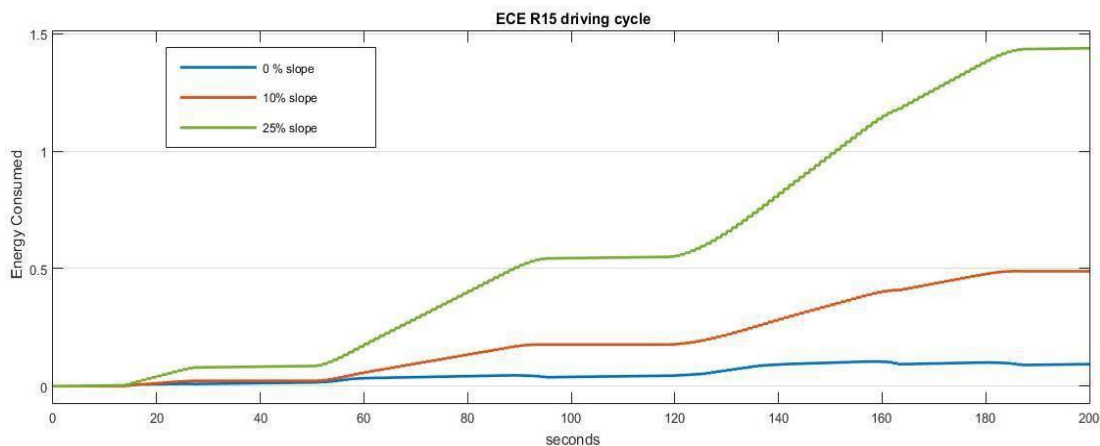

Fig.16: Energy consumed during ECE R15

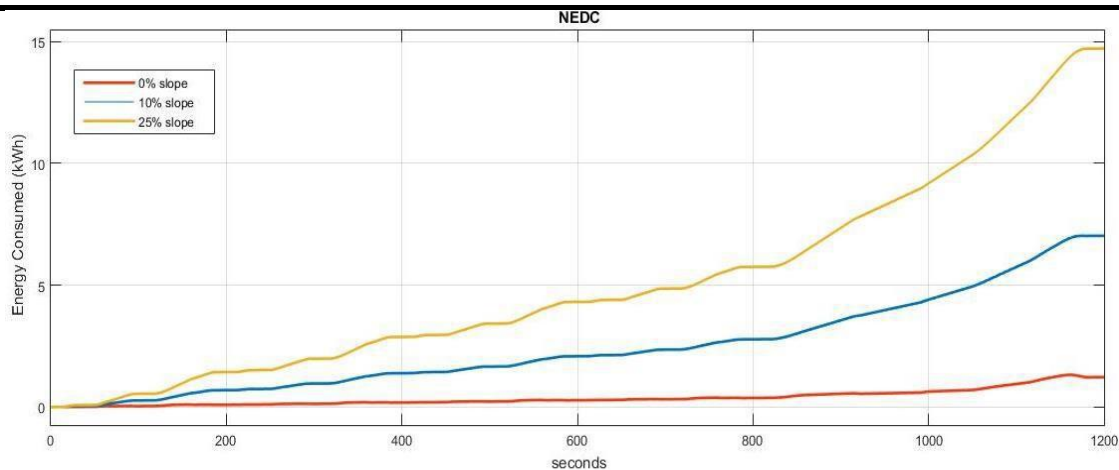

Fig.17: Energy consumed during EUDC

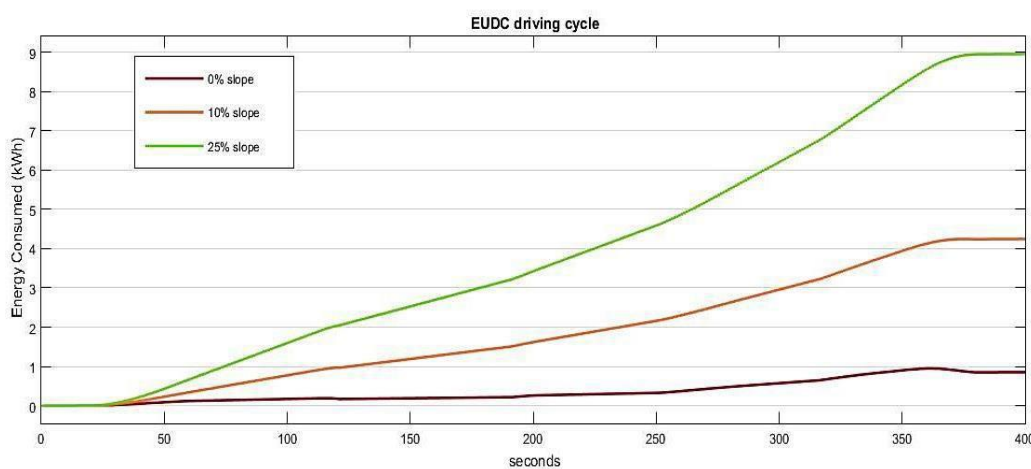

Fig.18: Energy consumed during

**State of Charges (SOCs) for different drive cycle for different slopes**

In this section we can see, SOC's left after each standard driving cycle and custom cycle. Each graph contains three different curves, which represents as different slopes. We can observe with the help of these graphs, we can conclude that slopes and velocity profile plays a major role in the variation of SOC of the electrochemical source.

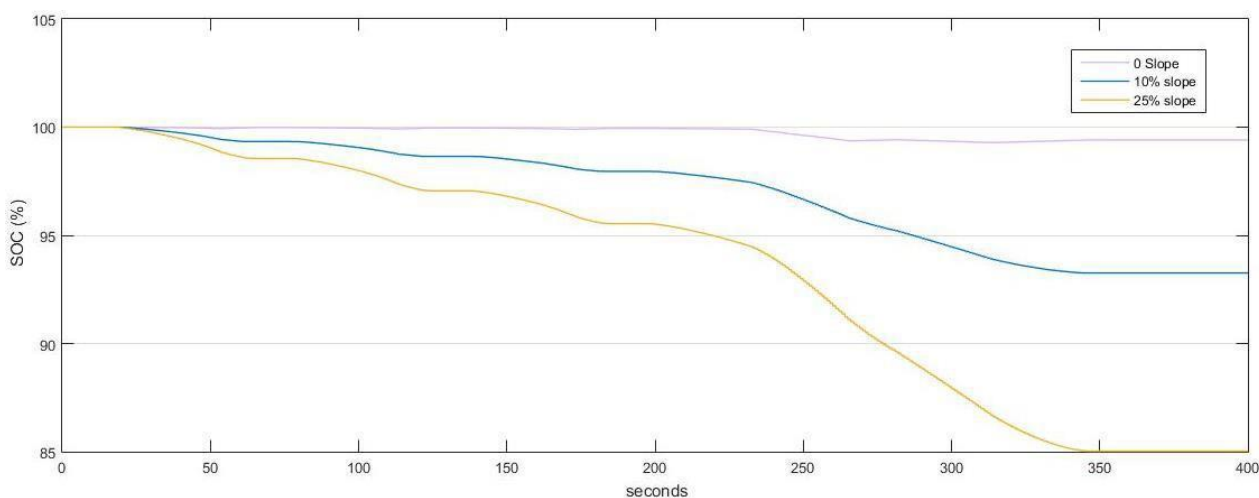

Fig.19: SOC's for SFUDS Driving Cycle

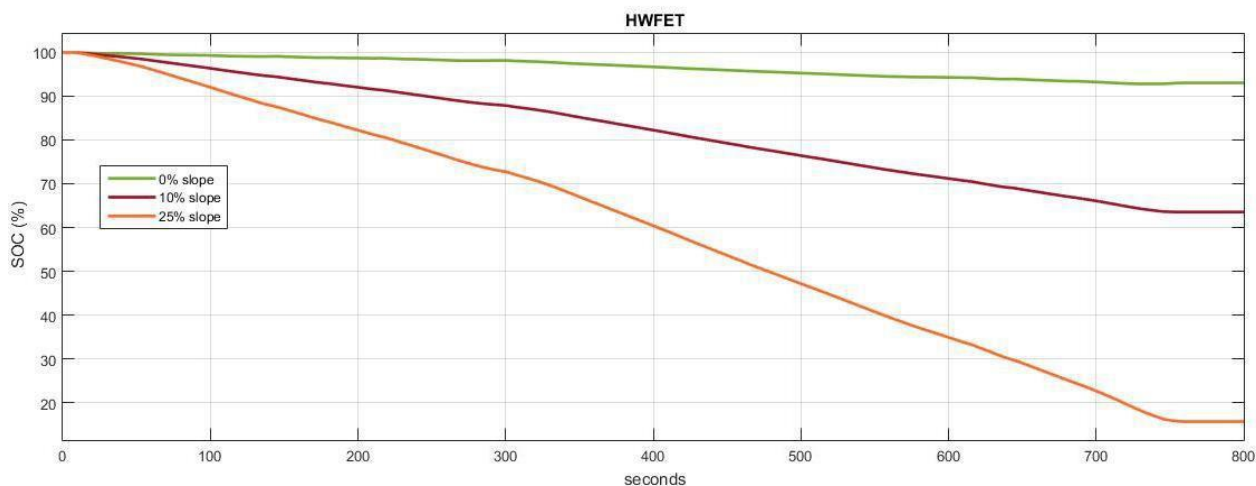

Fig.20: SOC's for HWFET Driving Cycle

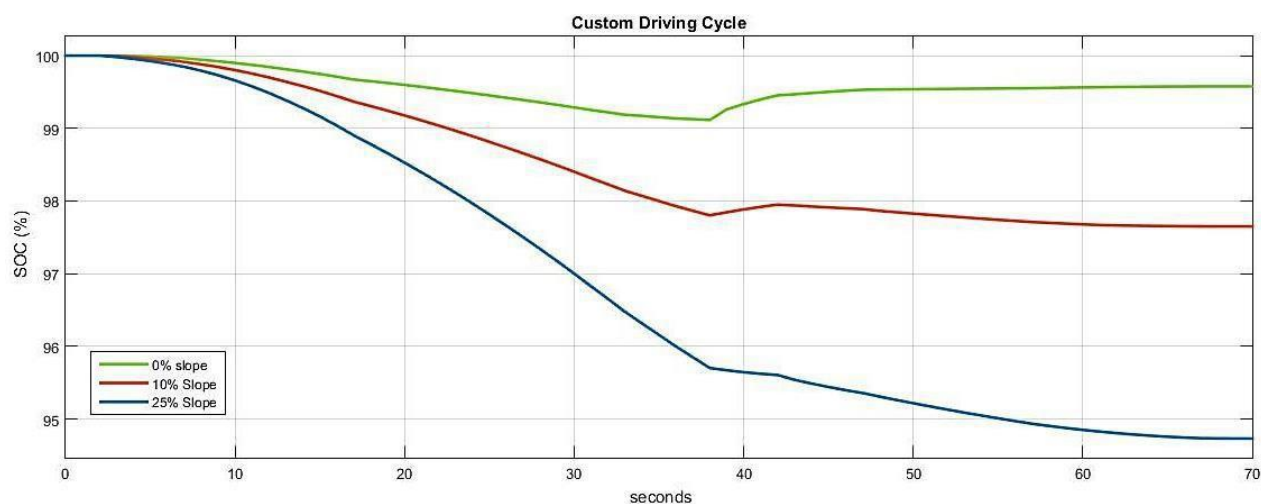

Fig.21: SOC at different slopes for Custom Driving Cycle

Table.4: Power and SOC at the end of driving cycles

Driving Cycle	Distance	Avg. Speed	Avg. Power (kW)	Time(s)	Max. Power	Slope pu	Auxiliary (kWh)	Final SOC (%)
NEDC	11.84	35.53	2.689	1200	26.06	0	0	96.64
NEDC	11.84	35.53	3.689	1200	26.06	0	1	69.64
NEDC	11.84	35.53	44.12	1200	143.43	0.25	1	40.80
NEDC	11.84	35.53	21.8	1200	71.73	0.1	1	73.58
ECE 15	1.12	20.27	12.51	200	24.20	0.1	1	97.61
ECE 15	1.12	20.27	1.686	200	6.17	0	1	99.87
ECE 15	1.12	20.27	25.89	200	54.22	0.25	1	94.66
EUDC	7.37	66.04	7.695	400	26.06	0	1	97.19
EUDC	7.37	66.04	38.21	400	71.73	0.1	1	83.60
EUDC	7.37	66.04	80.6	400	143.43	0.25	1	63.40

Table.5: Power and SOC at the end of driving cycles

Driving Cycle	Distance	Avg. Speed	Avg. Power (kW)	Time(s)	Max. Power	Slope	Auxiliary (kWh)	Final SOC (%)
Artemis(Urban)	4.46	16.06	1.68	1000	22.16	0	1	99.43
Artemis(Urban)	4.46	16.06	10	1000	41.74	0.1	1	90.30
Artemis(Urban)	4.46	16.06	21.19	1000	71.05	0.25	1	77.90
Artemis(Rural)	16.02	55.5	5.12	1100	30.93	0	1	95.30
Artemis(Rural)	16.02	55.5	31.58	1100	76.16	0.1	1	63.01
Artemis(Rural)	16.02	55.5	67.41	1100	143.36	0.25	1	14.60
SUFD	3.08	27.72	2.47	400	14.75	0	1	99.41
SUFD	3.08	27.72	16.70	400	45.55	0.1	1	93.30
SUFD	3.08	27.72	34.82	400	102.42	0.25	1	85.00
HWFET	16.52	74.36	9.20	800	18.80	0	1	93.00
HWFET	16.52	74.36	42.25	800	52.75	0.1	1	63.50
HWFET	16.52	74.36	89.86	800	110.71	0.25	1	15.60
Custom	1.07	54.92	6.808	70	33.38	0	1	99.58
Custom	1.07	54.92	32.68	70	74.58	0.1	1	97.60
Custom	1.07	54.92	68.87	70	145.49	0.25	1	94.73

## V. CONCLUSION

In this design and analysis work, I have covered introductory information of Electric Vehicles, with market survey. In addition to it, one can find sufficient information of the resistive forces acting on the vehicle while subject to different driving conditions, which in this work is being represented by standard and custom driving cycles.

The model created in this work is quite simple to understand and gives a fine idea of different forces acting on the vehicle while in motion, and against the slope (gravitational pull). When going through observations obtained via simulations at different slope and at different driving cycles, we can see that battery's state of charge depends on speed, acceleration, deceleration and slope on which vehicle is subjected. The variations of slope although is quite prominent and also plays a significant role in determining the SOC of battery, therefore range of the vehicle.

## REFERENCES

- [1] Abu-Rub, H., Iqbal, A., & Guzinski, J. (2012). *High Performance Control of AC Drives with Matlab*. Hoboken: John Wiley & Sons.
- [2] (2018). Retrieved from <http://mocha-java.uccs.edu/ECE5710/ECE5710-Notes02.pdf>
- [3] (2018). Retrieved from [http://web.mit.edu/evt/summary\\_battery\\_specifications.pdf](http://web.mit.edu/evt/summary_battery_specifications.pdf)
- [4] Batteries for Electric Vehicles: Materials and Electrochemistry Helena Berg. (2016). *MRS Bulletin*, 41(11), 919. doi: 10.1557/mrs.2016.262
- [5] Blog | Tesla Europe. (2018). Retrieved from [https://www.tesla.com/en\\_EU/blog/induction-versus-dc-brushless-motors](https://www.tesla.com/en_EU/blog/induction-versus-dc-brushless-motors).
- [6] Ehsani, M. *Modern electric, hybrid electric, and fuel cell vehicles*.
- [7] Electric and Hybrid Vehicles, Design Fundamentals [Book Review]. (2005). *IEEE Circuits And Devices Magazine*, 21(5), 26-27. doi: 10.1109/mcd.2005.1517392
- [8] Forcehimes, A., Bogenschutz, M., Sharma, G., Wilson, K., & Moyers, T. (2015). Fidelity monitoring model for an MI based brief intervention. *Drug And Alcohol Dependence*, 156, e72. doi: 10.1016/j.drugalcdep.2015.07.1115
- [9] Höök, M., & Tang, X. (2013). Depletion of fossil fuels and anthropogenic climate change—A review. *Energy Policy*, 52, 797-809. doi: 10.1016/j.enpol.2012.10.046
- [10] Motoring | Behind the wheel of the hydrogen Honda | Seattle Times Newspaper. (2018). Retrieved from [http://old.seattletimes.com/html/motoring/2008303425\\_hondahydrogen24.html](http://old.seattletimes.com/html/motoring/2008303425_hondahydrogen24.html)
- [11] Parra, F. (2010). *Oil politics*. London: I.B. Tauris.
- [12] Rising Internal Resistance - Battery University. (2018). Retrieved from [http://batteryuniversity.com/learn/article/rising\\_internal\\_resistance](http://batteryuniversity.com/learn/article/rising_internal_resistance)
- [13] Salih, Z., Gaeid, K., & Saghafinia, A. (2015). Sliding Mode Control of Induction Motor with Vector Control

- in Field Weakening. *Modern Applied Science*, 9(2).  
doi: 10.5539/mas.v9n2p276
- [14] Samreen N. Shaikh, Dr. S.R Patil(2016).Vehicle to Vehicle Communication System for Smart Cities. *International Journal of Advanced Engineering, Management and Science*(ISSN: 2454-1311),2(9), 1574-1578.
- [15] Scrosati, B. (2013). *Lithium batteries*. Hoboken, NJ: John Wiley & Sons, Inc.
- [16] Sun, C., Sun, F., & Moura, S. (2016). Nonlinear predictive energy management of residential buildings with photovoltaics & batteries. *Journal Of Power Sources*, 325, 723-731. doi: 10.1016/j.jpowsour.2016.06.076
- [17] Garcia-Valle, R., & Vlachogiannis, J. (2009). Letter to the Editor: Electric Vehicle Demand Model for Load Flow Studies. *Electric Power Components And Systems*, 37(5), 577-582. doi: 10.1080/15325000802599411
- [18] Sandeep Sharma, Rahul(2016).Impact of Cold Start on Vehicle Fuel Economy and Performance. *International Journal of Advanced Engineering Research and Science*(ISSN : 2349-6495(P) | 2456-1908(O)),3(7), 175-176.