

A variable gain PI to improve the performances of a unified power flow controller system

M. Sekour, M. Mankour, Kada Hartani

Laboratory of Electrotechnical Engineering, University Tahar Moulay of Saida, Algeria

Abstract— The instability problems in the electrical supply networks have had a great impact on recent research studies on modern devices. The unified power flow controller (UPFC) is one of the various FACTS (Flexible Alternative Current Transmission Systems) devices that allow the electrical supply networks to be stable with a strong effectiveness. In this paper, the performances of such a device using both a classical PI and a variable gains PI controllers are examined. For this instance, the compensator is first stabilized before trying to stabilize the network. A series of comparative simulation tests have been undertaken for both regulators and analyzed. From the obtained results it is clearly shown that when the system is equipped with the variable gain PI regulator, the performance are much better.

Keywords— Improvement, Unified power flow controller (UPFC), Variable gain PI controller

I. INTRODUCTION

The demand of efficient and high quality power is continuously growing in the world of electricity. Today's power systems are highly complex and require suitable design of new effective and reliable devices in deregulated electric power industry for flexible power flow control. In the late 1980s, the Electric Power Research Institute (EPRI) introduced a new approach to solve the problem of designing, controlling and operating power systems: the proposed concept is known as Flexible AC Transmission Systems (FACTS) [1, 2, 3, 4]. It is reckoned conceptually a target for long term development to offer new opportunities for controlling power in addition to enhance the capacity of present as well as new lines [5, 6]. in the coming decades. Its main objectives are to increase power transmission capability, voltage control, voltage stability enhancement and power system stability improvement. Its first concept was introduced by N.G.Hingorani in April 19, 1988. Since then different kind of FACTS controllers have been recommended. Controllers are based on voltage source converters and includes devices such as Static Compensators (SVC), static Synchronous Compensators (STATCOM), Thyristor Controlled Series Compensators (TCSC), Static Synchronous Series Compensators (SSSC)

and Unified Power Flow Controllers (UPFC). Among them UPFC is the most versatile and efficient device which was introduced in 1991. In , the transmitted power can be controlled by changing three parameters namely transmission magnitude voltage, impedance and phase angle. Unified Power Flow Controller (UPFC) is the most promising version of FACTS devices as it serves to control simultaneously all three parameters (voltage, impedance and phase angle) at the same time. Therefore it is chosen as the focus of investigation. For the last few years, the focus of research in the FACTS area is mainly on UPFC. Many researchers have proposed different approaches of installing UPFC in power systems [3, 4, 8, 11]. The concepts of characteristics have been broadly reported in the literature [5, 12].

II. OPERATING PRINCIPLE OF UPFC

The UPFC is connected in a simplified transmission system as shown in Fig 1. It's installed at the end of the transmission line to which it's connected through the two transformers T1 and T2 [6]. In Fig.1, the voltages and represent respectively the sources of three-phase sinusoidal voltage of the transmission line departure and arrival. The UPFC consists of two inverters controlled PWM (Pulse Width Modulation) placed back-to-back and connected to a capacitor [8, 9]. The series inverter provides the compensation voltage across the transformer series, while the parallel or shunt inverter provides or absorbs reactive power and active power demanded by the series inverter and regulates the voltage at the capacitor level. The active and reactive power are generated and absorbed independently by each inverter [11].

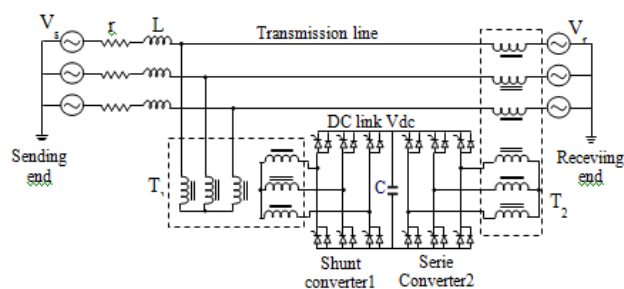

Fig. 1: Basic Circuit Arrangement of UPFC

III. MATHEMATICAL MODELING OF UPFC

The modeling process has enabled us to obtain equations for the various parameters of the different parts of the system and allowed us to have according to park a suitable model, where we can show the parameters of such an appropriate setting. The simplified circuit of the control system and UPFC compensation is shown in Fig.2.

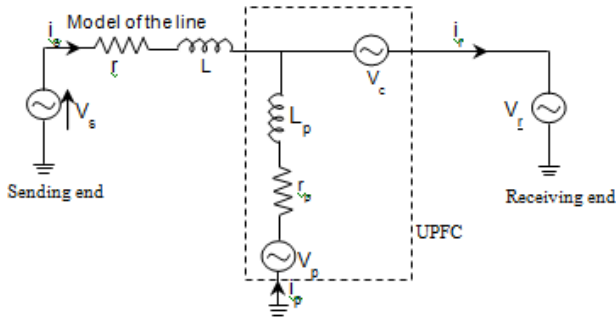

Fig.2: Equivalent circuit of the UPFC

The dynamic equations of the UPFC are divided into three systems of equations: equations of the series branch, equations of the parallel branch and those of the circuit of DC current.

By applying Kirchoff's laws we get the following equations for each branch.

3.1. MODELING OF SERIES BRANCH

It is supposed that the inverters series and shunt are ideal controllable voltage sources. Thus, from Fig 2, and by applying the Park transformation to the source voltages Vs and Vr we get the following equation:

$$\frac{di_{sd}}{dt} = \omega i_{sq} - \frac{r}{L} i_{sd} + \frac{1}{L} (V_{sd} - V_{cd} - V_{rd}) \quad (1)$$

$$\frac{di_{sq}}{dt} = -\omega i_{sd} - \frac{r}{L} i_{sq} + \frac{1}{L} (V_{sq} - V_{cq} - V_{rq}) \quad (2)$$

3.2. Modeling of the UPFC Continues Branch

Based on the principle of power balance and neglecting the losses of the converters, the voltage is obtained from the following equation:

$$\frac{dV_{dc}}{dt} = \frac{3}{2CV_{dc}} (V_{pd}i_{pd} + V_{pq}i_{pq} - V_{cd}i_{rd} + V_{cq}i_{rq}) \quad (3)$$

3.3. Adjustment of the UPFC

The active and reactive powers P and Q are given by the equations:

$$P = \frac{3}{2} (V_{rd}(i_{sd} + i_{pd}) + V_{rq}(i_{sq} + i_{pq})) \quad (4)$$

$$Q = \frac{3}{2} (V_{rd}(i_{sq} + i_{pq}) - V_{rq}(i_{sd} + i_{pd})) \quad (5)$$

The reference power and reactive P* and Q* of the desired real powers P and Q are used as input to the control system of UPFC. From equation (7) the reference currents i_{sd}^* and i_{sq}^* can be calculated as follows.

$$i_{sd}^* = \frac{2}{3} \left(\frac{P^* V_{sd} - Q^* V_{sq}}{V_{rd}^2 + V_{rq}^2} \right) \quad i_{sq}^* = \frac{2}{3} \left(\frac{P^* V_{sq} + Q^* V_{sd}}{V_{rd}^2 + V_{rq}^2} \right) \quad (6)$$

These reference values are then compared with actual line currents from the receiver. The outputs of the editors provide the current values of control voltages Vsd and Vsq. The goal is to have active and reactive power at the finish line (Receiving End) identical to those instructions (P*,Q*) by forcing the line currents (i_{sq}^*, i_{sd}^*) to monitor properly their references. The reference currents calculated (6) compared to the actual line currents and after a correction to the current one ends control voltages (UPFC series) and V_{cq} representing the reference voltage control circuit pulse modulation wide (PMW) of the inverter. Fig.3 represents the series UPFC control.

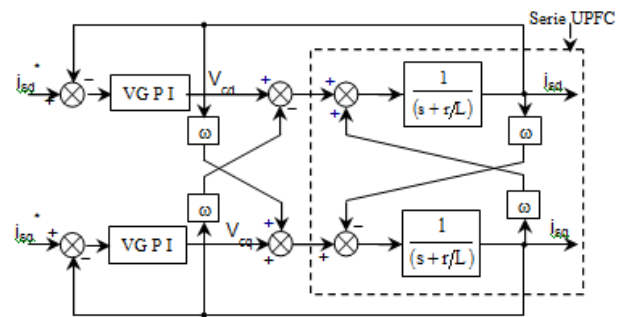

Fig.3: Block Diagram of the UPFC Control (Serie)

IV. DECOUPLED PI CONTROLLER

According to the system of equation (5) one can have the system contains a coupling between the reactive and active current. The interaction between current loops caused by the coupling term (ω) Fig.3. This explains the deviation of reactive power with respect to the reference. To reduce the interaction between the active and reactive power, a decoupling of the two current loops is needed. The function of decoupling is to remove the product ωLi_{qs} and controller along the axis and adding the product term ωLi_{ds} and the controller along the axis q. There is various adjustment techniques well suited to the PI controller [8, 9]. So according to the method of Ziegler-Nichols, the critical gain K_{pc} and the period T_c of the oscillations is measured by the choice of the table as follows:

Table.1. Ziegler–Nichols method

Control Type	K_p	T_i	T_d
PI	$0.45K_{pc}$	$0.83T_c$	0

V. VGPI CONTROLLER STRUCTURE

The use of controllers to control the UPFC is often characterized by an overshoot in tracking mode and a poor disturbance rejection. This is mainly caused by the fact that the gains of the controller cannot be set to solve the over shoot and disturbance rejection problems simultaneously [10]. Overshoot elimination setting will cause a poor disturbance rejection, and rapid disturbance rejection setting will cause important overshoot or even instability in the system. To overcome this problem, we propose the use of variable gains controllers.

A variable gain (VGPI) controller is a generalization of a classical controller where the proportional and integrator gains vary along a tuning curve as given by Fig.4 and Fig.5. Each gain of the proposed controller has four tuning parameters [9, 11]:

- Gain initial value or start up setting which allows overshoot elimination.
- Gain final value or steady state mode setting which allows rapid disturbance rejection.
- Gain transient mode function which is a polynomial curve that joins the gain initial value to the gain final value Fig .4.
- Saturation time which is the time at which the gain reaches its final value.The degree of the gain transient mode polynomial function is defined as the degree of the variable gain controller. If is the signal input to the VGPI controller then the output is given by:

$$i(t) = K_p e(t) + \int_0^t K_i e(\tau) d\tau \quad (8)$$

$$K_{pi} = \begin{cases} \left(K_{pf} - K_{pi} \left(\frac{t}{t_s} \right)^n + K_{pi} \right) & \text{if } t < t_s \\ K_{pf} & \text{if } t \geq t_s \end{cases} \quad (9)$$

$$K_i = \begin{cases} K_{if} \left(\frac{t}{t_s} \right)^n & \text{if } t < t_s \\ K_{if} & \text{if } t \geq t_s \end{cases} \quad (10)$$

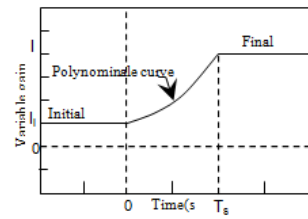

Fig .4: VGPI Tuning Curve

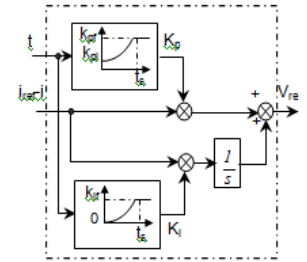

Fig .5: VGPI controller

Where K_{pi} and K_{pf} are the initial and final value of the proportional gain K_p , and K_{if} is the final value of the integrator gain K_i . The initial value of K_i is taken to be zero. It is noted that a classical PI controller is a VGPI controller of degree zero.

The VGPI unit step response is given by:

$$i(t) = \begin{cases} K_{pi} + \left(K_{pf} - K_{pi} + \frac{K_{if}}{n+1} t \right) \left(\frac{t}{t_s} \right)^n & \text{if } t < t_s \\ K_{pf} + K_{if} \left(t - \frac{n}{n+1} t_s \right) & \text{if } t \geq t_s \end{cases}$$

VI.

(11)

If $t > T_s$ (transient region), the classical PI unit step response is a linear curve beginning at K_{pf} and finishing at $K_{pf} + T_s K_{if}$, whereas the VGPI unit step response ($n \neq 0$) varies along a polynomial curve of degree $n+1$ beginning at K_{pi} and finishing at $(K_{pf} + T_s K_{if}) / (n+1)$. If $t \geq T_s$ (permanent region), the unit step responses of a PI and a VGPI controller are both linear with slope K_{if} . From these results, one can say that a VGPI controller has the same properties than a classical PI controller in the permanent region with damped step response in the transient region. A VGPI controller could then be used to replace a PI controller when we need to solve the load disturbance rejection and overshoot problems simultaneously.

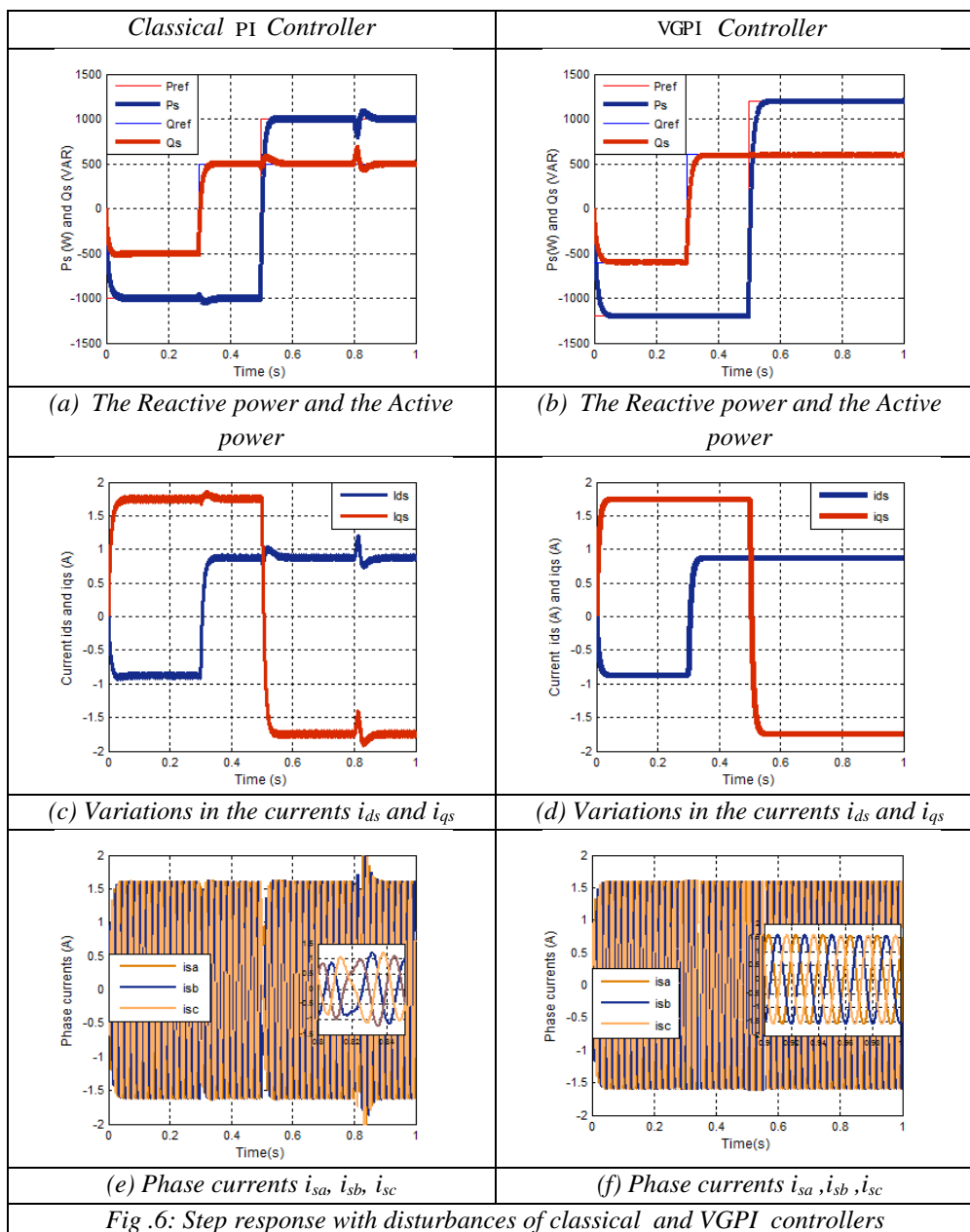

To assess the sensitivity to disturbances of the controllers we introduced at $t=0.8s$ a disturbance of amplitude equal to $\omega/5$ and a duration of $0.2s$. Fig.6 (a, c, e) illustrates the behaviour of active and reactive power and current, where we see that the control system has a fast dynamic response to the forces reach their steady states after a change in the reference values. We also note the presence of the interaction between the two components. These influences are caused by the inverter is unable to produce continuous signals needed by the decoupling, thus increasing the error in the PID controllers. The results given by fig.6 (b, d, f) show excellent performance in regulation for the VGPI controller with very good monitoring of the reference powers and currents. It can also be noted that the interaction and disturbance rejection

are excellent for the VGPI controller which also provides better performance in terms of power and time disturbance rejection.

VII. ROBUSTNESS

In order to verify the robustness of VGPI regulator under UPFC parameters variations, we have simulated the system with inductance step variation at $t=0.7s$ and resistance graduated variation between ($t=0.7s$ and $0.8s$) fig.7, fig.8. Fig.9 (b, d, f) shows the responses powers and currents in the test of robustness when the transmission line parameters are changed in a relative large range. The results indicate that the VGPI regulator is insensitive to the parameters change which results in zero influence on the power and current. An increase of

the parameters does not have any effect on the performances of the proposed controller. The VGPI

controller rejects rapidly the parameters disturbance

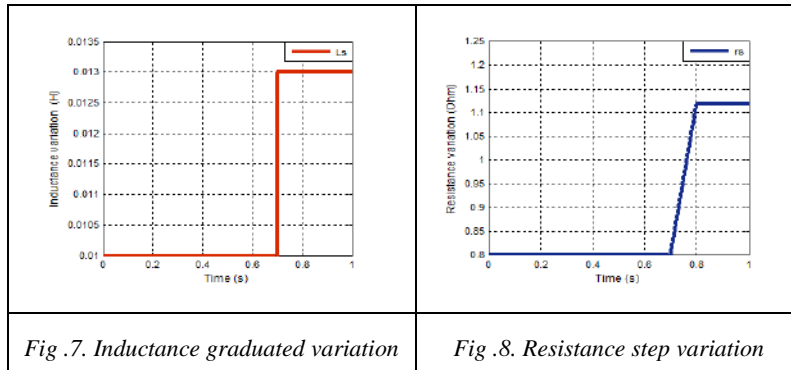
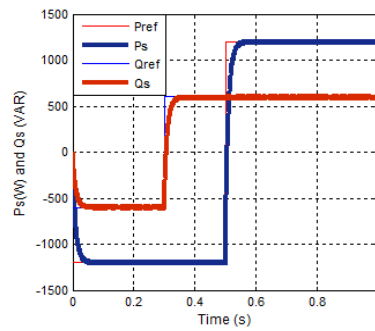
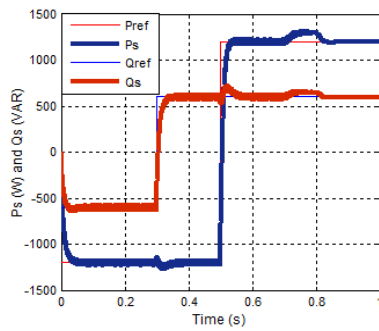

Fig .7. Inductance graduated variation

Fig .8. Resistance step variation

Classical PI Controller

VGPI Controller



(a) The Reactive power and the Active power

(b) The Reactive power and the Active power

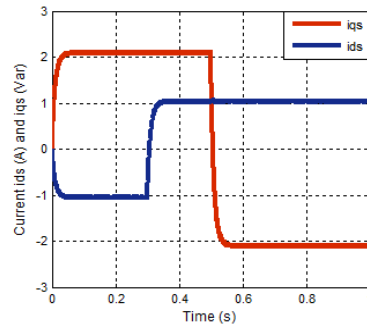
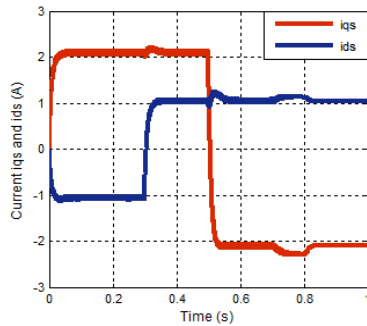

(c) Variations in the currents i_{ds} and i_{qs}

(d) Variations in the currents i_{ds} and i_{qs}

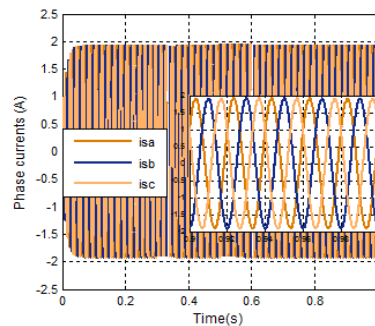
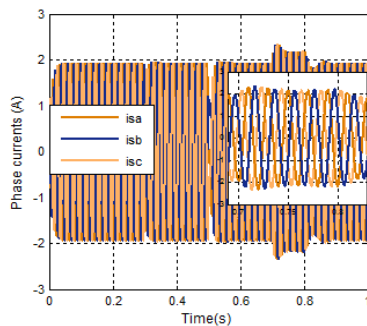

(e) Phase currents i_{sa}, i_{sb}, i_{sc}

(f) Phase currents i_{sa}, i_{sb}, i_{sc}

Fig .9 :Step response with disturbances of classical and VGPI controllers

VIII. CONCLUSION

The performance of the UPFC under classical and VGPI method control was investigated. A UPFC located at the middle of the transmission line was modelled realistically by transforming its variables into a rotating synchronous reference frame. The developed control concept shows an excellent dynamic behaviour and behaves robust to parameter changes of the power system. In conclusion it seems that classical PI controllers could be transformed to high performance robust controllers just by varying their gains. Our perspective is to develop a variable gain Fuzzy Logic controller for power control.

APPENDIX

Table.II.System parameters

Parameter name	Symbol	Value	Unit
Voltage of network	V_s	220	Volt
Voltage of loads	V_r	220	Volt
DC link voltage	V_{dc}	280	Volt
Frequency	f	50	Hz
Capacitor	C	2000	μF
Resistance of the line (serie)	r_s	0.8	Ω
Inductive reactance of the line (serie)	L_s	10	mH
Resistance of the line (shunt)	r_p	0.4	Ω
Inductive reactance of the line (shunt)	L_p	10	mH

REFERENCES

[1] K.Narendra, K. Parthasarathy *Identification and control of dynamical systems using neural networks*, IEEE Trans. Neural Networks, Vol 1, pp 4-27,(1990).[2] F-C.Chen, *Back propagation neural networks for nonlinear self-tuning adaptive control*, IEEE Control System Magazine, Special Issue on Neural Networks for control - pp 45-48,(1990).
 [3] F-C.Chen, *Adaptive control of a class of nonlinear discrete-time systems using neural networks*,IEEE Trans. Automatic Control, Vol 40, n° 7, pp 791-801, (1995).
 [4] L. Jin et al, *Adaptive control of discrete time nonlinear system using recurrent neural networks*, IEE Proc. Control Theory Applications, Vol 141, n° 3, (1994).
 [6] J. Henriques, A. Dourado,,*A Hybrid Neural-Decoupling Pole Placement Controller and its Application* , accepted for presentation in ECC99 - 5rd

European Control Conference, Karlsruhe, Germany, 31 August – 03 September 1999.
 [7] S. Zebirate, A. Chaker, *Commande hybride du système UPFC*, RS série RIGE. Volume 7- n° 1-2/, pages 75 à 104, (2004).
 [8] Sheng-Huei Lee ,Chia-Chi Chu.,*Power Flow Models of Unified Power Flow Controllers in Various Operating Modes*. IEEE Trans. Power Elect. 0-7803-8110-6/03, (2003).
 [9] H. Fujita,Y. Watanabe ,H. Akagi, *Dynamic Control and Performance of a Unified Power Flow Controller for Stabilizing an AC Transmission System*, IEEE Trans. Power Elect. 21(4): 1013-1020, (2006).
 [10] A.Miloudi, Al Radadi, A. Draou,, *A Variable Gain PI Controller Used for Speed Control of a Direct Torque Neuro Fuzzy Controlled Induction Machine Drive*, Turkish Journal of Electrical Engineering, VOL.15, NO.1, pp. 37-49, (2007).
 [11] M.Sekour,A.Chaker,M. Benyahya,S. Zeberate , *Deffect of instability in supplay network and improvementwith UPFC and VGPI*, AMSE Journal, Association for the Advancement of modeling & Simulation, USTHB, Alger Algeria july 02-05, (2007).
 [12] Arup Ratan Bhowmik,Champa Nandi, *Implementation of Unified Power Flow Controller (UPFC) for Power Quality Improvement in IEEE 14-Bus System*, International Journal of Computer Technology and Applications, Vol. 2, Issue 6, (2001).