

# Distance Cautious IP - A Systematic Approach in VANETS

B. Chandrasekaran<sup>1</sup>, C.Parthasarathy<sup>2</sup>

<sup>1</sup>Research Scholar, SCSVMV University, Enathur, Kanchipuram, Tamil Nadu, India

<sup>2</sup>Assistant Professor, Department of IT, SCSVMV University, Enathur, Kanchipuram, Tamil Nadu, India

**Abstract**— VANET is a decentralized network that allows the vehicles to communicate with each other for providing safety warning, traffic management and driver assistance systems. Vehicular IP in Wireless Access in Vehicular Environments (VIP-WAVE) has characterized the IP configuration for extended and non-extended IP services, and a mobility management scheme supported by Proxy Mobile IPv6 over WAVE. As the vehicular networks are formed even in remote areas with inadequate power source, the units have power constraints which are overcome by power control in the proposed system. The objective of the paper is to improve the quality of the network by providing internet access with transmit power control along which the distance between the RSU and on-board vehicular units (OBU) is determined i.e., power consumption is reduced when at least distance. Hence the RSU provides Distance Cautious Internet Protocol (DCIP) to the OBU for internet access. This paper analyses the WAVE standard and its support of IP based applications, and proposes Distance Cautious Internet Protocol in WAVE (DCIP-WAVE).

**Keywords**— VANET, RSSI, Internet Protocol (IP), IPv6, NS2, SUMO, TraNS.

## I. INTRODUCTION

Wireless network formed by the dynamic vehicles and the road side units to communicate among themselves is termed as Vehicular Ad-hoc networks (VANET). VANET does not have a pre-existing infrastructure and is built impulsively as devices connect. The vehicles nearby communicate among themselves (V2V) and with RSUs (V2I) to share information. The vehicles are equipped with gadgets that sense its surroundings and evaluate upcoming vehicles around it and prompt probable accidents in advance. For instance, if a prior vehicle user is about to change lanes or a subsequent vehicle is about to approach, the vehicle in the surroundings are warned about the changes. This way, the vehicle users are allowed to visualize the route using the sensed and received data. VANET is a smart communication network that promotes both safety and non-safety applications. The vehicles demand for information such as surrounding traffic situation, routes, accident prone zones

and much more. Driver assistance and car safety are considered as the most important ones of all the factors. This information includes data mainly from other cars and from roadside units. The messages include brake warning, collision warning, information about road condition and maintenance, intersection safety, emergency vehicles, speed management.

Apart from safety applications, new mercantile opportunities tend to enhance the non-safety applications to promote the technology, resulting in cost efficient systems. The vehicle users are offered with support and entertainment to make the drive more pleasant with comfort and infotainment (information + entertainment) applications. An in-vehicle infotainment system comprises of tasks such as managing and playing audio, choosing directions using navigation systems, entertainment such as movies, games, social networking, etc., listening to incoming and sending outgoing SMS text messages, making phone calls and accessing Internet-enabled content such as traffic conditions, sports scores and weather forecasts. VANET thus encourages information sharing, Cooperative driving and services like Navigation and Internet access.

## II. WAVE ARCHITECTURE

WAVE is essential to support the short-range communications in vehicular network. The communication between onboard units of vehicles or between the onboard unit of vehicles and the roadside unit relies on the band of 5.9 GHz. WAVE supports multi-hop communication for vehicles out of range. Using the system designed for OBU that is installed in the vehicle and the unit present on the road, WAVE provides the real time traffic information, to extend the safety of the transportation.

The strict latency constraint for emergency communications has resulted in the definition of the IEEE 802.11p and the Wireless Access in Vehicular Environments (WAVE), which together describe a low-latency alternative network for vehicular communications. In order to support infotainment traffic, WAVE uses IPv6 and transport protocols. By supporting IP-based communications, the

vehicular network might instantly be connected to other IP-based networks.

Two standards, IEEE 802.11p and IEEE 1609 contributes to the Wireless Access for Vehicular Environments (WAVE). The IEEE 802.11p amendment describes a technique to exchange data for the RSU and OBU which communicates only for a short period of time. The complete protocol stack of 1609 protocol family was introduced by IEEE and was named as WAVE. Each of the sub-standards of 1609 family handles different issues as different layers. 1609.3 and 1609.4 Standards define the Media Access Channel (MAC) capabilities for multichannel operation, the management and data delivery services between WAVE devices. The 1609.3 specifies the support of IPv6 link-local, global, and multicast addresses in WAVE devices. The standard signifies that link-local addresses should be derived locally for the IP configuration.

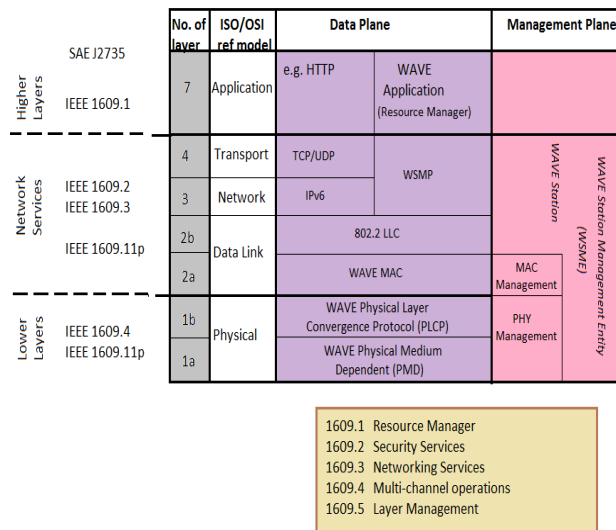

Fig.1: WAVE stack of protocols

The WAVE frequency spectrum is divided into one control channel (CCH) and six service channels (SCHs), each with 10 MHz bandwidth. In addition, each channel has its own set of access categories and its own instance of the 802.11p MAC layer. IEEE 802.11p is an approved amendment to the IEEE 802.11 standard and details the MAC Layer of the WAVE architecture.

Among the different types of frames that can be swapped in WAVE, management frames could be transmitted by either CCH or SCH. In contrary, data frames should be transmitted in SCH. Furthermore, the 802.11p radios can be single-physical layer (single-PHY) or multiple physical layer (multi-PHY). Single-PHY allows the radio module to exchange information only in one single channel at all times. As a result, a single-PHY has to constantly toggle between CCH and SCHs every certain time. The latter indicates the radio is able to monitor the CCH while at the same time it can exchange data in one or more SCHs.

WAVE uses two service sets:

- **WAVE Basic Service Set (WBSS):** It defines communication between Onboard unit and Roadside unit. It is similar to 802.11a specification which was used for communication of nodes with the access points. After receiving the beacon message, any vehicle can join the WBSS.
- **WAVE Independent Basic Service Set (WIBSS):** This service supports communication between two nodes without the participation of the roadside unit. WBSS is used for communication between the vehicles (V2V).

### III. PROPOSED SYSTEM

In the proposed system, the Distance Cautious IP has been integrated with the WAVE framework for maintaining IPv6 global addresses in WAVE devices, which is customized according to the type of user service and to support the IP mobility for seamless infrastructure-based communications.

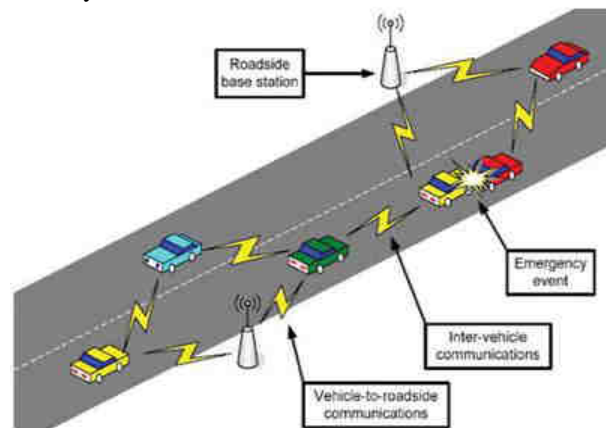

Fig.2: VANET Model

#### DCIP-WAVE Framework

The DCIP-WAVE framework addresses the limitations of power consumption in VANETs by integrating IP configuration and IP mobility in accordance with the distance based power control.

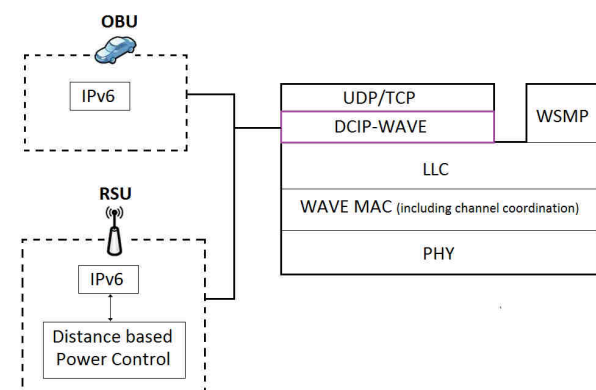

Fig.3: DCIP-WAVE Framework

The architecture of DCIP-WAVE is located in the data plane of the WAVE stack of protocols as illustrated in fig.3,

and it defines two main factors that interact with the standard IPv6 protocol:

- 1) the IP addressing and block of RSU which is responsible for allocating global IPv6 prefixes to OBUs and guaranteeing IP mobility all over the network.
- 2) Estimation of distance which acts as a key feature for power management.

Table 1 Set-Up Procedure in DCIP-WAVE

Procedure at OBU	
1:	Send beacon signal
2:	if (OBU receives IPService segment)
3:	Create and send a IPResponse segment that includes OBU's ID and IP address to RSU
4:	Associate a channeldetails segment with SCH number of active IP service
Procedure at RSU	
5:	if(Signal from OBU is received at a distance<threshold distance)
6:	Control transmit power and send IPService segment with WSA in CCH
7:	if(OBU's IP is already registered)
8:	Assign available IP, create Confirmation IP (CIP)
9:	Send CIP and add IP address to the record
10:	else
11:	Create CIP and copy the received IP (EIP) address of the OBU and Step 9

**Integration of DCIP-WAVE in vehicular networks**

The OBUs in the vehicles interact directly (one-hop) with the RSU by one hop link. Based on this one hop communication, the RSU that provides IP services calculates signal strength. The declaration of IP services takes place in the WAVE Service Advertisement (WSA) management frame. The RSU declares an IP service which includes the type of service, RSU's MAC address to identify it as the WAVE provider, and the threshold RSSI value. The Wave Service Advertisement (WSA) is transmitted in the CCH. The OBUs within one hop area from RSU observe the CCH and are capable of receiving WSA. The RSU maintains a record of active OBUs and their IP addresses to identify replicas of the IP addresses. The RSU compares the global IP address of the OBU with the active IPs and assigns a new IP on detecting a replica. If the OBU does not have a global IP address, it requests the RSU for an IP address by using RSU's MAC address as the frame destination. The RSU now sends a message including information required for an IPv6 configuration. Now that the IP address is assigned, OBU starts communicating with the RSU.

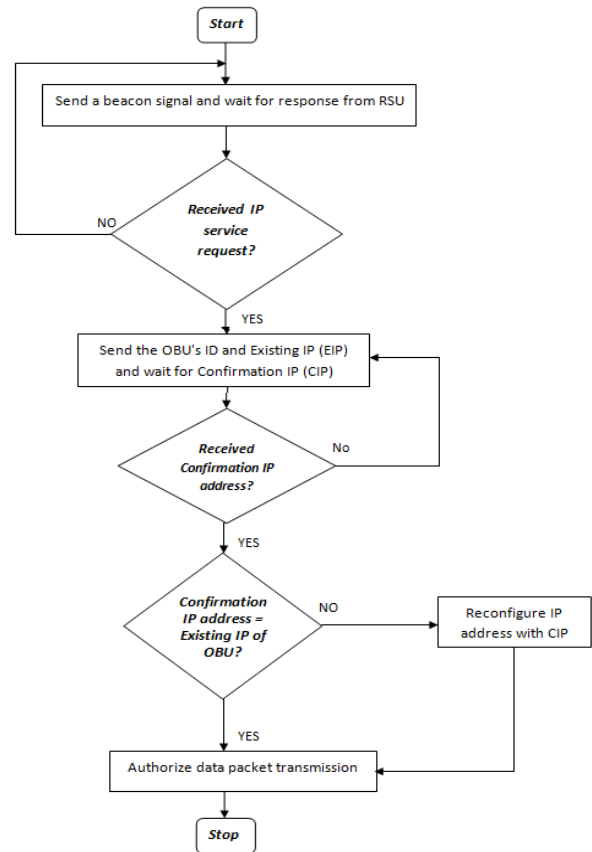

Fig.4: OBU's behaviour mechanism

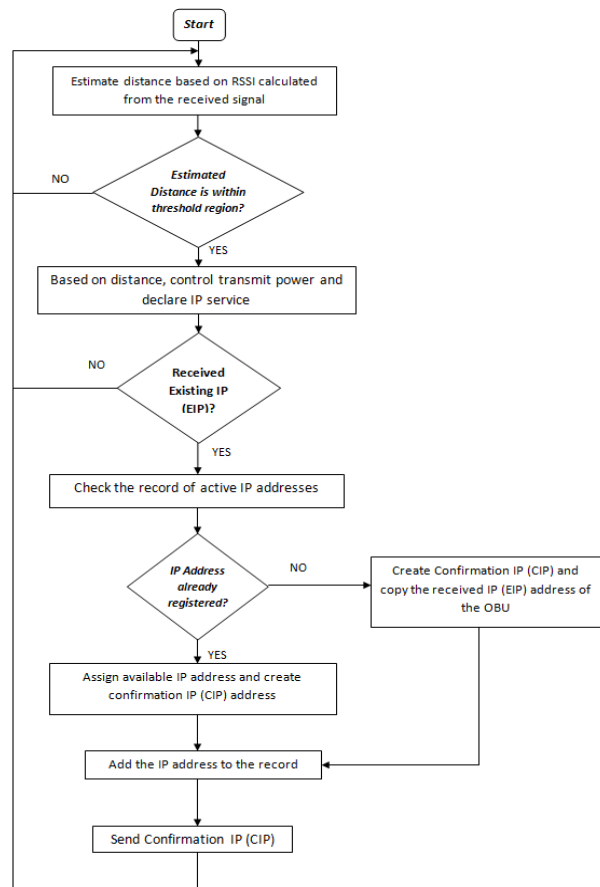

Fig.5: RSU's Behaviour Mechanism

**Distance estimation for Power Control**

Power controls the intelligent selection of transmitter power output in a communication system to achieve a better performance within the system. Better performance includes optimizing metrics such as link data rate (LDR), throughput, life of the network and network devices. Based on the distance calculated between the OBU and RSU, the transmit power is controlled. Considering in theory, the energy of a radio signal weakens with the distance from the signal's source. Hence, a OBU listening to a RSU's transmission is capable of using the strength of the received signal to estimate its distance from the RSU. The transmit power level is decreased as the distance between the RSU and OBU decrease, thereby increasing the lifetime of the modules at the RSU and throughput of the system. RSSI proposes an smart solution to the hardware ranging problem as all the OBU modules are likely to have radios which can be used to compute ranges. Received Signal Strength Indication (RSSI) is the measurement of power present in a radio signal.

Thus we integrate RSSI based distance estimation in determining connectivity. The distance above the threshold results in a detachment of communication from the vehicle to the provider RSU. The RSSI and distance relationship can be represented by using the following formula,

$$d = 10^{[(P_o - F_m - P_r - 10n \log_{10}(f) + 30n - 32.44) / 10n]}$$

- d - distance between the OBU and RSU,
- n - Path-Loss Exponent,
- Po - Signal power (dBm) at zero distance,
- Pr - Signal power (dBm) at distance d,
- f - Signal frequency in MHz
- Fm - Fade margin is the difference between the strength of the received signal at the antenna port and the minimum signal strength in dB. The higher the fade margin, the more reliable the link will be.

$$\text{Fade Margin} = \text{System gain} + \text{Antenna gain} - \text{Cable loss} - \text{Path loss}$$

- n - Path loss exponent represents the path loss whose value is normally in the range of 2 to 4 (where 2 is for propagation in free space, 4 is for relatively lossy environments).

$$L = 10n \log_{10}(d) + C$$

**IV. SIMULATION RESULTS**

The VANET scenario has been created by using the NS2, Trans and sumo simulators. The results have been verified with the real-time mapping of road traffic using SUMO simulator. These results have been tested in ns2 environment for obtaining the performance characteristics of DCIP-WAVE.

Table 2 Performance Evaluation Parameters

Parameter	Value
Transmit Power at RSU	14mW
Frequency Band	5.9 GHz
Data rate	4Mbps
RSSI Threshold	-85dBm
Speed	35 km/hr
Length	75m
Distance between RSUs	50m
Time Out (in seconds)	5

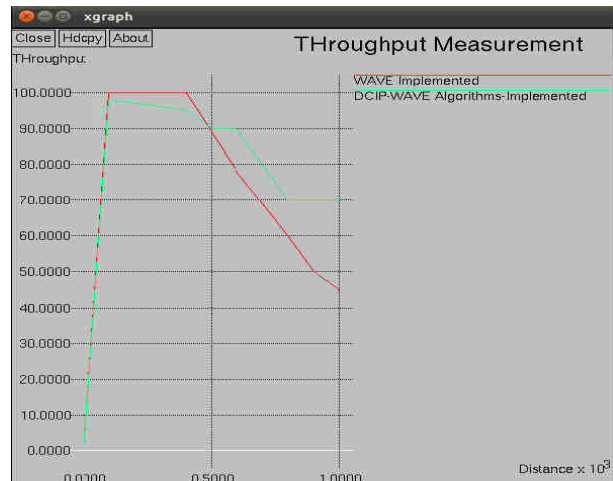

Fig.6. Throughput obtained when the vehicles are arriving at a speed of 35km/hr

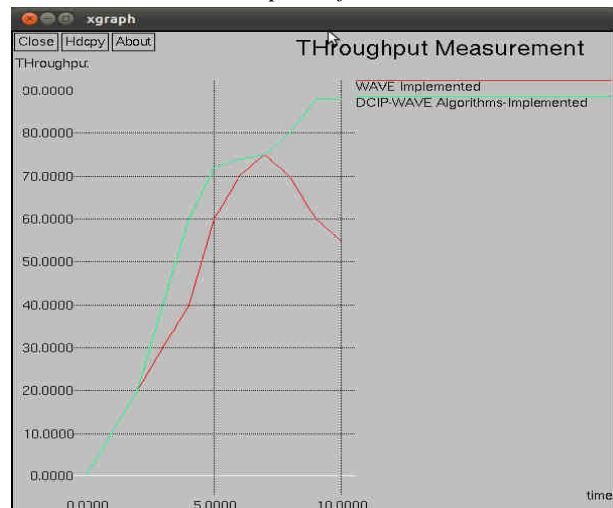

Fig.7. Overall throughput obtained with respect to time



Fig.8. Decrease of Power consumption based on Distance between RSUs

## V. CONCLUSION

Hence a mechanism proposed in DCIP-WAVE for IP addressing and one-hop communications has been designed using WAVE protocol. The refinement of the protocol has been integrated successfully with the IP service which is highly dependent on the distance and results in power control with increase of throughput and data rate.

## REFERENCES

- [1] Sandra Céspedes, Ning Lu, Xuemin Shen, "VIP-WAVE: On the Feasibility of IP Communications in 802.11p Vehicular Networks" IEEE Transactions on Intelligent Transportation Systems, Vol. 14, No. 1, March 2013
- [2] Nasreddine Lagraa, Mohamed Bachir Yagoubi and Sarah Benkouider, "Localization technique in VANets using Clustering (LVC)" IJCSI International Journal of Computer Science Issues, Vol. 7, Issue 4, No 9, July 2010
- [3] Saurabh Kumar Gaur, S.K.Tyagi, Pushpender Singh, "VANET System for Vehicular Security Application" International Journal of Soft Computing and Engineering (IJSCE), Volume-2, Issue-6, January 2013
- [4] Tajinder Kaur, A. K. Verma, "Simulation and Analysis of AODV routing protocol in VANETs" International Journal of Soft Computing and Engineering (IJSCE), Volume-2, Issue-3, July 2012
- [5] Pratap Kumar Sahu, Eric Hsiao-Kuang "DuRT: Dual RSSI Trend Based Localization for Wireless Sensor Networks" IEEE Sensors Journal, Vol. 13, No. 8, August 2013
- [6] Kittikhun Thongpull, Nattha Jindapetch, and Wiklom Teerapabkajorndet, "Wireless ESD Event

Locator Systems in Hard Disk Drive Manufacturing Environments" IEEE Transactions on Industrial Electronics, Vol. 60, No. 11, November 2013

- [7] Priya. V "Cloud Service for Best Gateway in VANET" International Journal of Advanced Research in Computer Science and Software Engineering, Volume 4, Issue 4, April 2014
- [8] "Intelligent Transport Systems (ITS); Vehicular Communications; GeoNetworking; Part 6: Internet Integration; Sub-Part 1: Transmission of IPv6 Packets Over GeoNetworking Protocols", Technical Specification, European Telecommunications Standards Institute (ETSI), vol. 1, Nov. 2011