

# Design, Modeling and Failure Analysis of Rolling Key in 10-Ton C-Type Mechanical Power Press

Prof. Amit B Solanki<sup>1</sup>, Vishal Chuahan<sup>2</sup>, Gajjar Mitesh<sup>3</sup>, Shah Darshan<sup>4</sup>

<sup>1</sup>Assistant Professor, Mechanical Engg. Dept., CCET-Wadhwan, Gujarat, India

<sup>2,3,4</sup>B.E. Students, Mechanical Engg. Dept., CCET-Wadhwan, Gujarat, India

**Abstract**— Mechanical presses (c-type) are dangerous machines and have caused major accidents over the years, these accidents are mostly occurring due to failure of different type of components in mechanical press like key (clutch pin), shaft, gears. When working with either full or part revolution out of failure of key leads, failure of other components and ultimately mechanical press system. The objective of present work is to study about causes of failure of key and by analysis to reduce failure of key due to shearing and crushing. It is found out that shearing and crushing are the major criteria for the failure of key. In this project work modeling of key by using CREO software and analysis using finite element analysis (ANSYS software) help to prevent and safe designing key of mechanical power press.

**Keywords**— Mechanical power press, rolling key.

## I. INTRODUCTION

A power press is defined in PUMER as “a press or press brake for the working of metal by means of tools, or for die proving, which is power driven and which embodies a flywheel and clutch”. A press is a sheet metal working tool with a stationary bed and a powered ram can be driven towards the bed or away from the bed to apply force or required pressure for various metal forming operations. The relative positions of bed and ram in the press are decided by the structure of its frame.

Mechanical power press is a machine that shear, punches, forms or assembles metal or other materials by means of tools or dies mounted on slides or rams. It operates in a controlled, reciprocating motion towards and away from the stationary bed containing the lower die.

Key is a component to transfer torque from the rotating shaft to rotary element of the machine. It restricts relative rotational motion and axial movement between the shaft and the machine element.

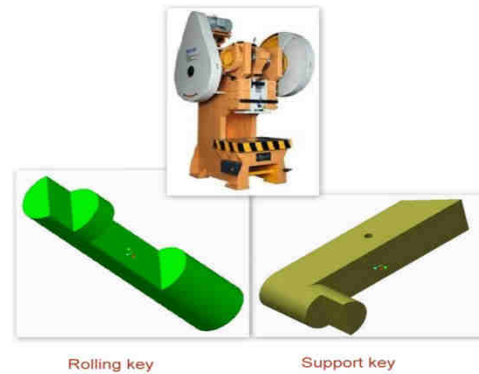

Fig.1.1: C-type Mechanical Power Press and Key

## II. POWER PRESS PARTS

1. Frame :The frame is of all steel construction fabricated from rolled steel plates with suitable cross fibbing, presses up to 30t will be supply with C.I. Leges and full steel body proper alignment of the frame ensured by machining.
1. Bending causes tensile and compressive stresses.
2. Clutch: The clutch is of rolling key-type. The clutch is rigid and well supported. The clutch gives continue stroke for mass production.
3. Crank Shaft & Bearing: Crank shaft is made of special alloy steel machined to close accuracy and fitted in bronze bushes for smooth working.
4. Flywheel: properly sized flywheel, is made of high grade cast iron. For storing and releasing adequate energy for the pressing operations and properly balanced for smooth running.
5. Gears: Gears are of steel cast. Gear teeth are generated by precision hobbing machine.
6. Rolling Key: Rolling key is made of low carbon steel. It is fitted between clutch and gear.
7. Table & Ram: Table and ram are made of high grade heavy duty cast iron and properly season. They are perfectly aligned to each other to obtain high accuracy and precision press operation.
8. Lubrication: an efficient shot lubrication system has been provided for lubrication. The sliding surfaces and moving parts. The lubricant applied by hand pump.

### III. KEY

Function of Key:

1. The primary function of key is to transfer torque from the rotating shaft to rotary element of the machine.
2. The second function of the key is to restricted relative rotational motion and axial movement between the shaft and the machine element.

Classification of Keys:

1. Saddle keys
  - a. Hollow saddle key
  - b. Flat saddle key
2. Sunk keys
  - a. Taper sunk keys
  - b. Parallel sunk key
  - c. Feather keys
3. Woodruff key (adjustable key)
4. Round keys
  - a. Parallel pin
  - b. Taper pin

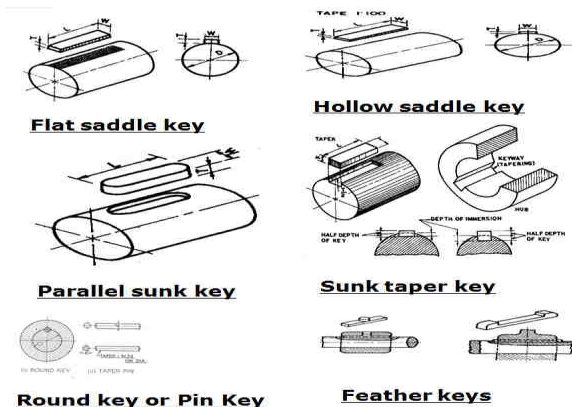

Fig.1.2: key

### IV. STRESSES IN KEY

1. Shear failure: It occurs when key is sheared across its width at the interface between shaft and hub.

Average shear stress due to direct shear is define in equation

$$\tau_{xy} = F/A_{\text{shear}}$$



Fig.1.3: Shearing failure of key

2. Crushing failure: It occurs when localized compressive stress at the area of contact between two

components which not having relative motion between them.

$$\sigma_{xy} = F/A_{\text{crushing}}$$



Fig.1.4: Crushing failure of key

### V. TECHNICAL DATA OF MECHANICAL POWER PRESS

Table 1.1 Power press Specification

Model	Power press
Type	Mechanical, C type
Crank shaft diameter	55mm
Stroke	51mm
Capacity	10-ton
Hole in ram	32mm
Hole in bed	76mm
H.P.Required	1
Weight in kg.	650

### VI. DESIGN PROCEDURE OF KEY

The following procedure may be adopted for designing a rolling key.

1. Maximum shear stress for shaft.
2. Maximum shear stress for key.
3. Maximum torque transmitted for shaft and key.
4. Find length of key.

#### Calculation of key :

Given data:

1.  $\sigma_{yt}$  for shaft = 370 Mpa
2.  $\sigma_{yt}$  for key = 294.74 Mpa
3. shaft diameter = 50 mm

According to maximum shear stress theory,

$$\tau_{\text{max}} = \sigma_{yt} / 2 * f.s$$

$$= 370 / 4$$

$$= 93 \text{ N/mm}^2$$

According to maximum shear stress theory for the key,

$$\tau_k = \sigma_{yt} / 2 * f.s$$

$$= 294.74 / 4$$

$$= 74 \text{ N/mm}$$

We know that maximum torque transmitted by the shaft and key,

$$T = \pi/16 * \tau_{\max} * D^3$$

$$= \pi/16 * 93 * (50)^3$$

$$= 2269125 \text{ N-mm}$$

First of all let us consider the failure of key due to shearing.

We know that maximum torque transmitted (T)

$$T = L * \sigma_{ck} * D/2 * W$$

$$2269125 = L * 74 * 25 * 12.5$$

$$= 99\text{mm}$$

Consider the failure of key due to crushing. We know that the maximum torque transmitted (T).

$$T = L * \sigma_{ck} * D/2 * t/2 \dots\dots\dots(1)$$

$$\sigma_{ck} = \sigma_{yt} / f.s$$

$$= 294.74 / 2$$

$$= 148 \text{ N-mm} \dots\dots\dots(2)$$

Equation 2 is put in equation 1

$$T = L * \sigma_{ck}$$

$$2269125 = L * 148 * 25 * 4.5$$

$$L = 105.89 \cong 106 \text{ mm}$$

Table 1.2 Dimension of Rolling Key

O.D	LENGTH
25	106

2-D and 3-D Model of key :

After calculating manual design of rolling key we conclude the design data as shown in above table by considering above calculated dimension of rolling key we make a model of rolling key in Cre-O. Model of rolling key is as shown in bellow fig.

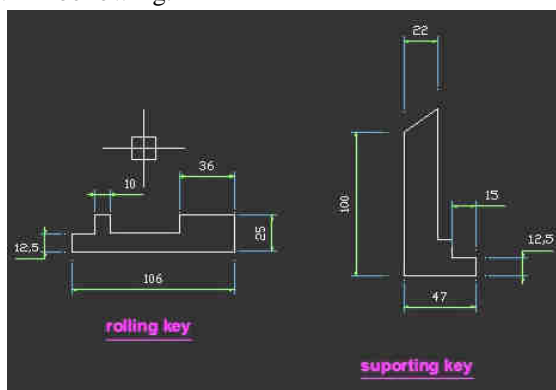

Fig.1.5: 2D Modelling of key

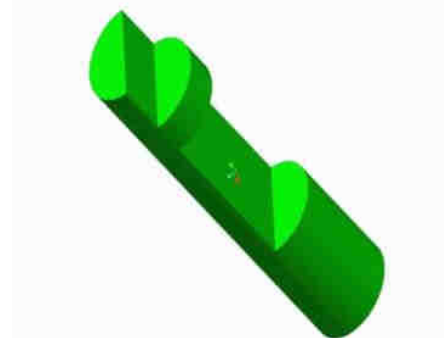

Fig.1.6: 3D Modelling of key



3D Modelling of support key

Fig.1.7:

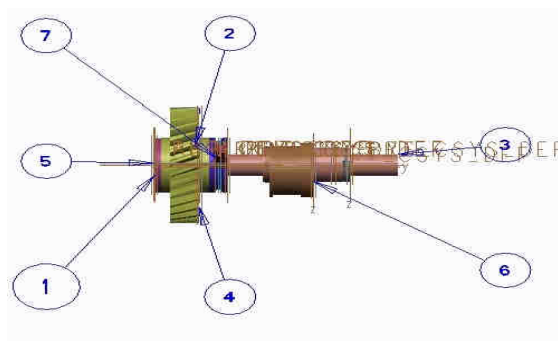

Fig.1.8: Assembly of Power Press with Key

1	BUSHSUPPORT.006	MILD STEEL	1
2	CLUTCH	MILD STEEL	1
3	ECCENTRIC.SHAFT	MILD STEEL	1
4	HELICAL.GEAR	MILD STEEL	1
5	ROLLING.KEY	LOW CARBON STEEL	1
6	SHAFT.RING	MILD STEEL	1
7	SUPPORT.KEY	LOW CARBON STEEL	1
SR NO	PART NAME	MATERIAL	NOS

## VII. CONCLUSIONS

By modification of key and keyway we expect that it will improve the life of components and reduce failure of rolling key during operation by taking different materials for key. We will also improve design of key and related parts to reduce failures. By considering alternate methods

of key shaft mechanisms we will try to improve efficiency of power press.

#### **ACKNOWLEDGMENT**

The support extended by the CCET (C.U.Shah College of Engg. & Tech) and college authorities is highly appreciated and acknowledged with due respect.

#### **REFERENCES**

- [1] Vishakha V. Meshram and pravin M Wanjari : A review paper of design and analysis of rolling key.
- [2] Niels L. Pedersen : optimization of key way, design 2<sup>nd</sup> international conference on engineering optimization.
- [3] Ravi D : computer aided design and analysis of power press, middle east journal of scientific research, vol 20, No. 10, pp. 1239-1246.
- [4] Joseph Shigley and Charles Mischke. Mechanical Engineering Design, 1998, McGraw hill, Inc, USA
- [5] P>C>Sharma and D.K.Agarwal. A textbook of machine design 1998, S.K Kataria and sons.
- [6] R.S.Khurmi "A text book of machine design "internal combustion engine parts- S Chand publication, New delhi.
- [7] Design Data, Databook of Engineers, Compiled by PSG college of Technology Coimbatore, Published by Kalaikathir AchchagamCoimbatore ©1968, Revised edition 1970, Reprinted in January 2010