

# Enhancement of Analytical OBR (Out of Band Radiation) and BER Calculation for Digital Audio-Video Broadcasting in Companded OFDM System using Non-Symmetric QAM/QPSK Techniques

Santosh, Prof. Piyush Vyas, Prof. K. K. Arora

M. Tech. Scholar, Dept. of ECE Engg., J.I.E.T., Jodhpur, Rajasthan, India

Associate Professor, Dept. of ECE Engg., J.I.E.T., Jodhpur, Rajasthan, India

Associate Professor, HOD M.Tech. (DC), Dept. of ECE Engg., J.I.E.T., Jodhpur, Rajasthan, India

**Abstract**— Companding transforms useful under assumption of infinite bandwidth. Under band limited conditions OBR parameter filters out. So bandwidth is a factor that decides the filtering out OBR on the performance of companded OFDM systems. As a result filtering becomes essential under band limited conditions in turn this does deteriorate the system performance significantly. In this paper method proposed to overcome the performance degradation. Method called non symmetric scheme based on the use of curve fitting method to find out a suitable polynomial to be used for decompanding at the receiver. This method indeed improves the performance in comparison to existing symmetric methods when filtering is necessary for band limited conditions.

**Keywords**— Companding, OFDMA, CDMA, TDMA, FDMA, Digital Techniques and their performance.

## I. INTRODUCTION

Orthogonal Frequency Division Multiplexing (OFDM) is a digital modulation technique who consists of transmitting a data stream using a large number of parallel narrow-band sub carriers instead of a single wide-band carrier i.e. in OFDM multiplexing is applied to independent signals but these independent signals are a subset of one main signal. Therefore OFDM is a combination of modulation and multiplexing with better immunity to impulse noise and intersymbol interference (ISI), low complexity and high spectral efficiency. Implementation of OFDM modulation is illustrated by the OFDM system as shown in figure 1.1 .

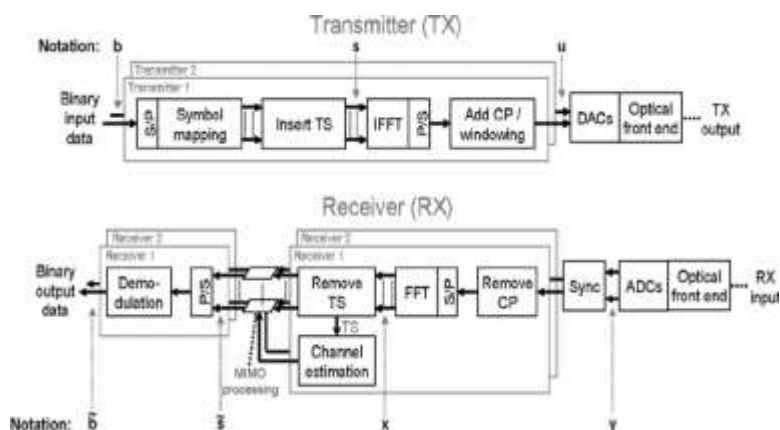

Fig. 1.1: OFDM System

## II. SYSTEM FUNCTIONING

**OFDM Transmitter:** Data coming from the input are arranged into vectors with number of components equal to the N number of carriers. Each component is composed by a number of bits depending on the alphabet of the modulation scheme used on the next stage. Each component (group of bits) is mapped into a complex symbol depending on the alphabet of the modulation scheme used[3]. The Inverse Fast Fourier Transform algorithm (IFFT) is applied to the vector giving a real samples vector. The guard interval is added at the beginning of the vector by repeating the components of the end. Vectors are concatenated to form a time signal (parallel/serial conversion). Windowing the signal is necessary to limit the bandwidth. Most used window is the raised cosine.

**Channel :** The signal is then passed through the channel. Channel is modeled by a linear system with frequency res-

ponse  $c(t)$  together with a source of additive Gaussian noise[4].

**OFDM Receiver:** At the reception, signal is rearranged again into vectors (serial/parallel conversion) and guard interval is dropped. Fast Fourier Transform (FFT) is computed in order to get back the complex vector of symbols.

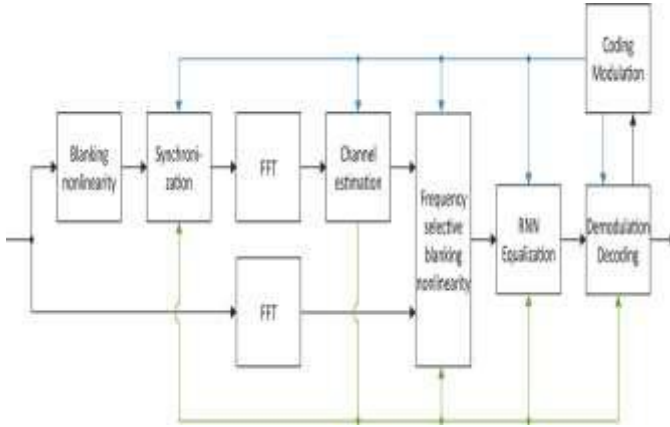

Fig.1.2: OFDM Receiver System

### III. COMPANDED OFDM SYSTEM

OFDM system has been used for the high-speed digital communications such as DAB (digital audio broadcasting), DVB (digital video broadcasting), digital high definition television (HDTV) and asymmetric digital subscriber line (ADSDL) due to robustness to the narrowband interference and severe multi-path fading. One major difficulty, however, is its large peak-to-average power ratio (PAPR) which reduces the resolution of the digital-to-analog (D/A) and analog-to-digital (A/D) converters in the transmitter and receiver[2]. A simple as well as an effective companding technique to reduce the peak-to-average power ratio of OFDM signal. The idea is to make use of companding in speech processing. Since OFDM signal is similar to speech signal in the sense that large signals only occur very infrequently, the same companding technique can be used to improve OFDM transmission performance. The block diagram of OFDM system with commanding technique is shown in fig 1.2 as follows.

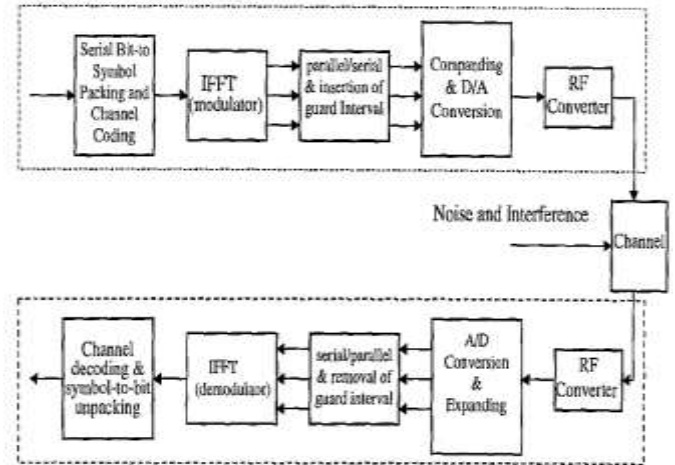

Fig.1.3: Proposed Companded OFDM System

### IV. LIMITATIONS IN COMPANDED OFDM SYSTEM

In companded OFDM system the PAPR of OFDM signals is reduced by increasing the average power of signals while keeping the peak unchanged, but this reduction in PAPR may be very limited under certain BER performance constraint. i.e. Out of band radiation (OBR), filtering in system and even the bandwidth plays a key role on the performance of companded OFDM systems [1].

#### Problem Statement

- Companding transforms mitigate the effects of OFDM only under sufficient bandwidth.
- Band limited case; the OBR value is not satisfied. Thus we filter the OBR parameter.
- To avoid PAPR regrowth companding parameters are tighten to compress large amplitude and enhance small amplitude. In spite of these remedies, the overall system performance degrades with BER performance degradation.

### V. PAPER WORK AND OBJECTIVE

- Analysis & study of the effects of filtering on the performance of various companding transforms.
- To overcome this and improve system performance, a simple effective method of Non symmetric companding and decompanding is used.
- To improve the performance degradation, Non symmetric companding and decompanding method is used based on the use of curve fitting method to find out a suitable polynomial, used for decompanding at the receiver. The main objective of this paper is to develop a method based on companding transform that provides a simple but effective tradeoff between reduction in

PAPR and bit error rate (BER) performance which is required in modern wireless transmission systems.

ber of sub carriers chosen is  $N=256$ , oversampling factor of 4.

**Clipping:** The clipping operation is done on the over sampled OFDM signal after the base band OFDM is digitally modulated into band pass signal [7]. The over sampled OFDM signal after IFFT is

$$X_k' = \begin{cases} X_{k+N/2}, & 0 \leq k \leq N/2 - 1 \\ 0, & N/2 \leq k \leq mN - N/2 - 1 \\ X_{k-(mN-N/2)}, & mN - N/2 \leq k \leq mN - 1 \end{cases} \quad (6.1)$$

To generate the bandpass signal digitally, let the bandpass carrier frequency  $f_c$  be  $1/4$  of the sampling frequency  $f_s$  then, the real bandpass samples can be written as

$$\begin{aligned} y_n &= x_n \cos(2\pi \frac{f_c}{f_s} n) - x_n \sin(2\pi \frac{f_c}{f_s} n) \\ &= x_n \cos(\frac{n\pi}{2}) - x_n \sin(\frac{n\pi}{2}). \end{aligned} \quad (6.2)$$

The output power of the clipped OFDM signals after the BPF is given by

$$\hat{P}_{av} \triangleq \frac{1}{N} \sum_{k=0}^{N-1} E \left[ |\tilde{A}_k|^2 \right] \quad (6.3)$$

Where  $A_k$  is the distorted version of the original data  $A_k$ . So the out band power to in band power is equivalent to average output power after clipping to the output power before clipping is less than or equal to 1 as shown by equation below and over sampling factor ( $J=1$ )

$$\frac{\hat{P}_{av}}{P_{out}} = \frac{\sum_{k=0}^{N-1} E \left[ |\tilde{A}_k|^2 \right]}{\sum_{k=0}^{JN-1} E \left[ |\tilde{A}_k|^2 \right]} \leq 1 \quad (6.4)$$

So the constant value of OBR/IBR is -15 under band limited case.

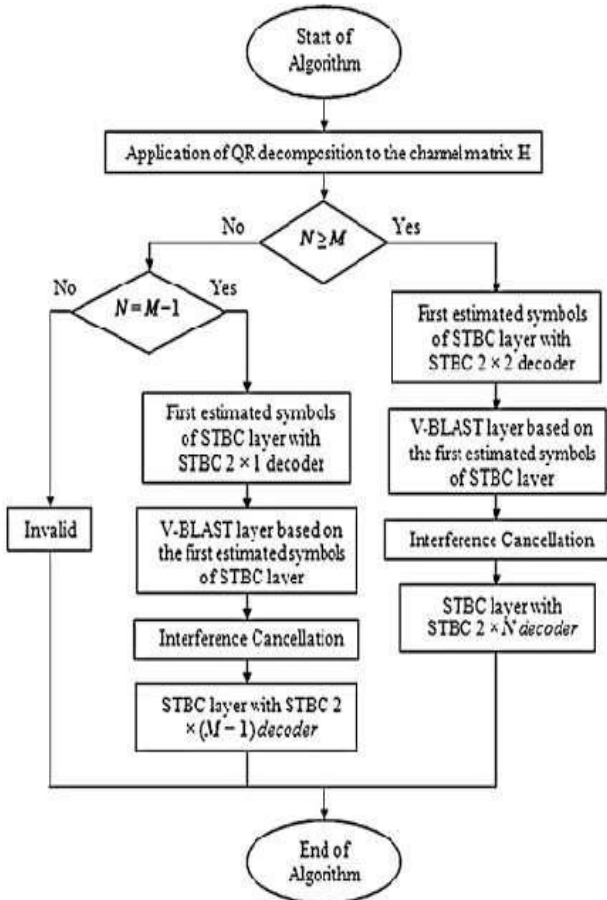

Fig.1.4: Proposed STBC Companded OFDM System based on FFT- IFFT functioning flow chart

**VI. ALGORITHM FOR SOLUTION APPROACH**  
**Calculation of OBR to IBR Ratio**

Unwanted emissions [15] are composed by out of band and spurious emission. Spurious emission according to ITU\_R recommendation defines that any unwanted emission which falls at frequencies separated from the centre frequency of the emission by 250% or more of the relevant channel separation, where the system is intended to be used, will generally be considered spurious emission. Out of band emissions, defined based on their source, occur in the out of band domain and, to a lesser extent in the spurious domain. Spurious emissions likewise may occur in the out of band domain as well as in the spurious domain. We also analyzed theoretically the average value of OBR to IBR ratio for clipping and different companding schemes that achieve a reasonable level of PAPR. The parameter constraints considered are target PAPR of 6.5 dB, CCDF of atleast  $10^{-5}$  at this value of PAPR. The modulation scheme used is QPSK and the num-

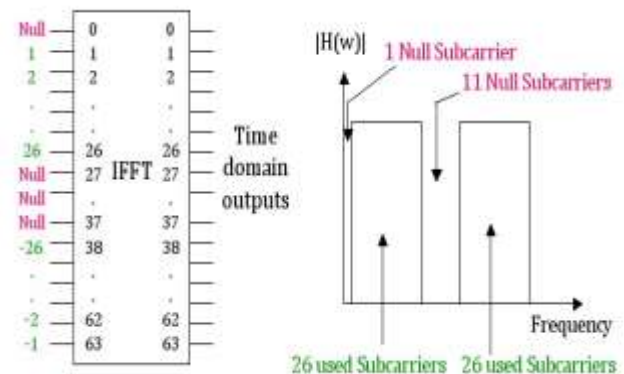

Fig 1.5: Distributive Subcarrier OFDM System

**Exponential Companding:** The outputs of the N-point Inverse Fast Fourier transform (IFFT) of  $S_k$  are the OFDM signal samples over one symbol interval [13], or mathematically

$$s_n = \frac{1}{\sqrt{N}} \sum_{k=0}^{N-1} S_k \exp\left(\frac{j \cdot 2\pi kn}{N}\right) \tag{6.5}$$

The amplitude, or modulus, of OFDM signal  $s_n$  is given by

$$|s_n| = \sqrt{Re^2\{s_n\} + Im^2\{s_n\}} \tag{6.6}$$

Considering the phase of input signals, the companding function  $h(x)$  is given by

$$h(x) = \text{sgn}(x) F_{\tau_n}^{-1} (F_{|s_n|}(x)) = \text{sgn}(x) \sqrt{\alpha \left[ 1 - \exp\left(-\frac{x^2}{\sigma^2}\right) \right]} \tag{6.7}$$

The positive constant  $\alpha$  determines the average power of output signals given by

$$\alpha = \left( \frac{E[|s_n|^2]}{E\left[\sqrt{1 - \exp\left(-\frac{|s_n|^2}{\sigma^2}\right)}\right]^2} \right)^{\frac{1}{2}} \tag{6.8}$$

Where  $\sigma^2 = E[|S_k|^2]/2$  is the common variance. So this constant determines the power OBR/IBR whose constant value is -12 under the case of limited bandwidth.

**A-Law Companding:** The OFDM signal samples in real form after inverse fast Fourier transform (IFFT) [10] can be formulated as

$$s(n) = \frac{2}{\sqrt{N}} \sum_{k=1}^{\left(\frac{N}{2}\right)-1} \left\{ a_k \cos\left(\frac{2\pi kn}{N}\right) + b_k \sin\left(\frac{2\pi kn}{N}\right) \right\} \tag{6.9}$$

$a_k - j b_k$  is the transmitted data for the  $k^{\text{th}}$  sub carrier and  $N$  is the IFFT size.

From the central limit theorem, the variance of the Gaussian distributed MCM signal can be easily determined as

$$\sigma_s^2 = \frac{2(N-2)}{N} P_s \tag{6.10}$$

Where  $P_s = E\{1/2(a_k^2 + b_k^2)\}$  is the signal power for each sub carrier.

The maximum peak value of OFDM signal is found as

$$A = (N-2) \sqrt{\frac{2P_s}{N}} \tag{6.11}$$

The A-law compressed OFDM signal in our proposed PAPR reduction technique is described by

$$s_c(n) = \begin{cases} \frac{\mu s(n)}{1 + \ln \mu} & 0 \leq s(n) \leq \frac{A}{\mu} \\ \frac{A + A \ln\left(\frac{\mu s(n)}{A}\right)}{1 + \ln \mu} & \frac{A}{\mu} \leq s(n) \leq A \end{cases} \tag{6.12}$$

Where  $\mu$  is the companding coefficient. So the maximum peak value determines the OBR/IBR ratio under band limited case whose value is -10.

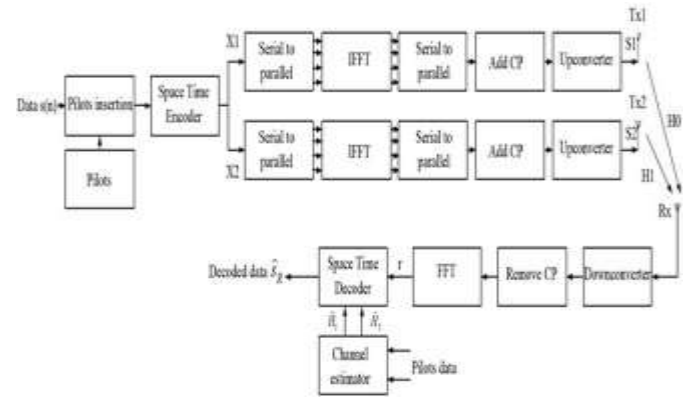

Fig 1.6 STBC functioning based transmitter receiver data communication OFDM System

**Linear Symmetric Transform (LST):** With linear symmetrical transform [10], the transmitted signals may be expressed by

$$S'_{k,m} = u \cdot S_{k,m} + \text{Sgn}(S_{k,m}) \cdot v \tag{6.13}$$

where  $0 < u \leq 1$  and  $0 < v \leq A$  are the transform parameters. Further, the received signal is

$$R'_{k,m} = S'_{k,m} + n_{k,m} + q_{k,m} \tag{6.14}$$

Where  $n_{k,m}$  denotes the AWGN term with zero mean and variance  $\sigma_0^2 = N_0/2$

Therefore the OBR to IBR ratio determined at the receiver using above equation and the constant value is -9 under band limited case.

**Non Linear Symmetric Transform (NLST)**

With NLST [10], the transmitted signals can be expressed by,

$$S'_{k,m} = \begin{cases} \text{Sgn}(S_{k,m}) \frac{M}{|S_{k,m}|} \ln\left[1 + \frac{u}{M} |S_{k,m}|\right], & |S_{k,m}| \leq M \\ \text{Sgn}(S_{k,m}) \frac{M}{v} \left\{ \exp\left[\frac{\ln(1+u)}{v} |S_{k,m}| - \text{Sgn}(S_{k,m}) M\right] - 1 \right\} + \text{Sgn}(S_{k,m}) M, & |S_{k,m}| > M \end{cases} \tag{6.15}$$

Where  $u > 0$  and  $0 < v \leq A - M$

By the inverse transform of the above equation, we get the received signal through which OBR to IBR ratio constant value is -14 under the band limited case.

**Non Linear Non Symmetric Transform (NLNST):**

The assumption of any type of companding is for NLNST. The transformed signals is expressed as



$$S'_{k,m} = Sgn(S_{k,m}) \frac{v}{\ln(1+u)} \ln \left( 1 + \frac{u}{v} |S_{k,m}| \right)$$

(6.16)

Where  $u > 0$  and  $0 < v \leq A$

For the case of large signal-to-noise ratio (SNR), the received signals through the inverse transform can be approximated as

$$R_{k,m} = Sgn(R'_{k,m}) \frac{v}{u} \left\{ \exp \left[ |R'_{k,m}| \frac{\ln(1+u)}{v} \right] - 1 \right\} \\ \approx S_{k,m} + \ln(1+u) \left[ \frac{1}{u} + \frac{|S_{k,m}|}{v} \right] (n_{k,m} + q_{k,m}).$$

(6.17)

The relevant OBR to IBR ratio under band limited case with receive and transmitted average power known the constant value is -13. By the above analysis we found that all the schemes are not able to meet the stringent requirement of OBR in order to prevent interference with adjacent channels and generally less than 1 [7].

**Simulation Results:**

Simulation was performed to measure the BER Vs SNR for various companding schemes with filtering and without filtering using symmetric method and verified PAPR calculation. The results were analyzed by taking following constraints  $N=256$  (no of subcarriers), target PAPR=6.5DB, modulation scheme used QPSK. BER Vs SNR analysis also done for the proposed technique non symmetric method for modulation schemes QPSK and 16-PSK. comparison done between symmetric and non symmetric methods and PAPR calculated for all schemes.

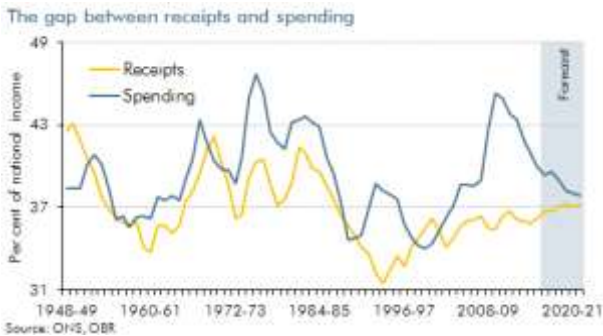

Fig.6.1: Performance Analysis of the Filtered and Non Filtered case for spending and receiving packets

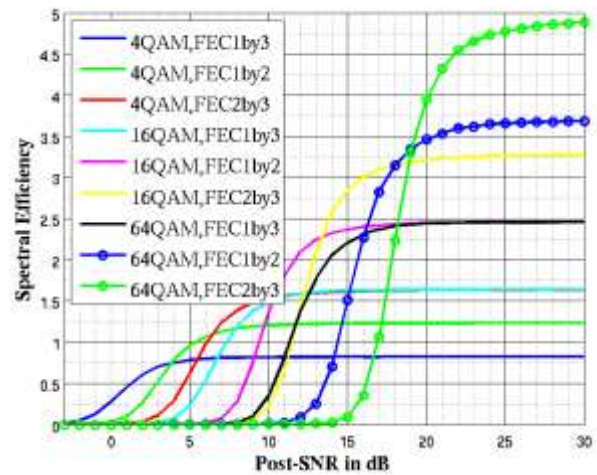

Fig.6.2 : Performance Analysis of spectral efficiency method with 4, 16 and 64 QAM w. r. t. FEC by 3

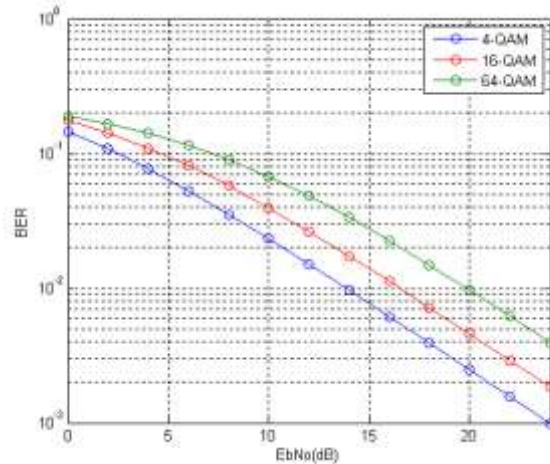

Fig.6.3 : Performance Analysis of BER with 4, 16 and 64 QAM w. r. t.  $E_b N_0$ (dB)

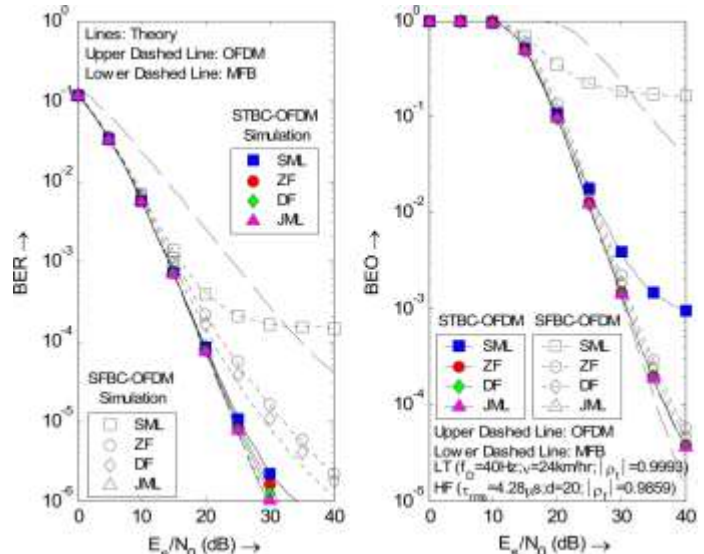

Fig.6.4 : STBC –OFDM Simulation for BER Performance

## VII. CONCLUSION

The poor performance of companding schemes under band limited conditions is portrayed. The impact of filtering and without filtering on various companding schemes and respective PAPR analysis infers that the required objective is met. A nonsymmetric companding method is used to improve the performance of this BER degradation in symmetric methods. Extensive simulation results and qualitative discussions have shown that the method used does perform better than previous symmetric method [16]. Main aspects of this research paper is to implement design a algorithm for following features like with comparisons of clipping and companding techniques, all the above simulation results show one common feature, with previous symmetric methods, achieved a better performance closely to clipping under band limited conditions, with proposed scheme. The future scope of the project is likely to be that we can put forth the proposed technique using some other advanced mathematical method or method from any respective domain like networking, optical to have further more reduction in target PAPR

## REFERENCES

- [1] "Non Symmetric Decomparing for Improved Performance of Companded OFDM System" IEEE Transactions on wireless communications VOL.6. NO.8. August 2007.
- [2] Y. S. Cho, J. Kim, W. Y. Yang and C. G. Kang, "MIMOOFDM Wireless Communications with MATLAB," Wiley, 2010, 263 Pages.
- [3] F. Meucci, "Multiple Input Multiple Output: From Signal Processing to Protocol Gain," Ph.D. Thesis, University of Florence, Florence, 2009.
- [4] S. M. Alamouti, "A Simple Transmit Diversity Technique for Wireless Communications," IEEE Journal on Select Areas in Communications, Vol. 16, No. 8, 1998, pp. 1451-1458.
- [5] Z. S. Wu, "MIMO-OFDM Communication Systems: Channel Estimation and Wireless Location," Louisiana State University, Ph.D. Thesis, Louisiana State University, Baton Rouge, 2006.
- [6] S. Kaiser, "Space Frequency Block Codes and Code Division Multiplexing in OFDM Systems," Global Telecommunications Conference, San Francisco, 1-5 December 2003.
- [7] K. Lee, Y. Kim and J. Kang, "Adaptive Switching between Space-Time and Space-Frequency Block Coded OFDM Systems," Military Communications Conference, Milcom, 2008, pp. 1-5.
- [8] L. Hanzo, J. Akhtman, M. Jiang and L. Wang, "MIMOOFDM for LTE, WIFI and WIMAX," Wiley IEEE Press, 2010, 591 Pages.
- [9] B. Sklar, "Rayleigh Fading Channels in Mobile Digital Communication Systems Part I: Characterization," IEEE Communications Magazine, Vol. 35, No. 9, 1997, pp. 90- 100.
- [10] D. Tse and P. Viswanath, "Fundamentals of Wireless Communication," Cambridge University Press, Cambridge, 2005. [doi:10.1017/CBO9780511807213](https://doi.org/10.1017/CBO9780511807213).
- [11] D. B. Lin, P. H. Chiang and H. J. Li, "Performance Analysis of Two-Branch Transmit Diversity Block Coded OFDM Systems in Time-Varying Multipath Rayleigh Fading Channels," IEEE Transactions on Vehicular Technology, Vol. 54, No. 1, 2005, pp. 136-148. [doi:10.1109/TVT.2004.838826](https://doi.org/10.1109/TVT.2004.838826).