

Improving the Voltage Stability and Performance of FACTS Controller in Transmission Line Network

Mr. Pravin B.Mali, Mr. Nilesh S. Mahajan

ME-II, Department of Electrical Engineering, SSBT's College of Engineering & Technology, Bambhori, Jalgaon, India
Assist. Prof, Department of Electrical Engineering, SSBT's College of Engineering & Technology, Bambhori, Jalgaon, India

Abstract— Conventionally Shunt Compensation is used to increase the transfer capability of a transmission line. By using FACT'S controllers one can manage the variables such as voltage magnitude and phase angle at selected bus and line impedance. Objective of this paper is to recover dynamic voltage control and consequently increasing system load ability for 50 Hz Frequency. Now a day, five well known FACT'S devices generally used for this purpose. These FACT'S devices are (SVC) Static VAR Compensator, (TCSC) Thyristor Controlled Series Capacitor, (STATCOM) Static Synchronous Compensator, and (UPFC) Unified Power Flow Controller and (SSSC) Static Synchronous Series Compensator.

The voltage drop occurs when a system is loaded beyond its highest load ability point, then many investigation methods have been projected for the study of this difficulty. Mainly of These techniques are based on the classification of system stability. These stable points are typically referred as points of voltage collapse. This paper present modeling and simulation of STATCOM & SVC in Matlab Simulink for dynamic voltage performance of transmission line network.

Keywords— FACTS controllers, dynamic performance of STATCOM & SVC, VAR, Voltage Stability.

I. INTRODUCTION

Power Generation, Transmission and Distribution are difficult process, requiring the working of many components of the power system in cycle to make the most of the output. One of the major components to form a main part is the reactive power in system. It is necessary to sustain the voltage to deliver the active power through the lines. Different types of load required reactive power for their operation. To improve the performance of ac power systems, we need to manage this reactive power in a resourceful way and this is called as reactive power compensation [2-3]. There are two aspects to the trouble of reactive power compensation: load compensation and voltage support. Load compensation consists of improvement in power factor, balancing of actual power drawn from the supply, better voltage regulation, etc. of large variable loads. Voltage support consists of decrease of

voltage variation at a given terminal of the transmission line. Series compensation and shunt compensation used to change in parameters of the system to give better-quality VAR compensation. In recent days, static VAR compensators like the STATCOM have been developed [4]. These quite satisfactorily do the job of absorbing or generating reactive power with a faster time response from (FACTS) Flexible AC Transmission system. FACTS devices allows an increase in transmission capability of apparent power through a transmission line and gives much better stability by doing adjustment of parameters that manage the power system. By using FACTS controllers control the variable elements such as voltage magnitude and phase angle at selected bus and line impedance [2]. There are five well known FACTS devices utilized by the utilities for this reason. Each of them has its-own characteristics and limits.

1.1 Troubles in Transmission line Network

There are so many problems happens in Transmission, Distribution and Utilization system they are as follows, Voltage Sag, Swells, Dynamic stability limit Voltage fall down, Transient stability limit, Reduce circulating reactive power, [3-5]. Voltage stability limit, Voltage flicker, Damping and oscillations etc. This paper present modeling and simulation of STATCOM & SVC for 50 Hz Frequency in Matlab Simulink for Impacts of SVC and STATCOM on power system are investigated during fault through and grid disturbance. Lastly Comparison of SVC and STATCOM are carried out for the duration of instability.

1.2 Advantages of Facts Controller

- 1) Increase the system security through raising the transient stability limit, limiting short circuit currents and over loads, managing cascading black-outs [3].& damping electro-mechanical oscillations of power systems and machines.
- 2) Provide secure tie-line connections to neighboring utilities and regions thereby decreasing overall generation reserve requirements both sides.
- 3) Provide upgrade of lines, Reduce the reactive power flow, thus allowing the lines to carry more active power.

4) Increase utilization of lowest cost generation & Reduce loop flows.

1.3 Types of Facts Controllers

FACTS controllers can be classified into three categories.

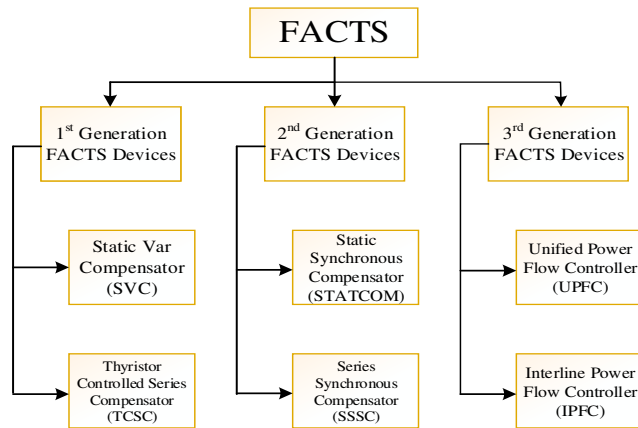

Fig. 1.1: Block diagram of FACTS Controller

A) STATCOM Controller

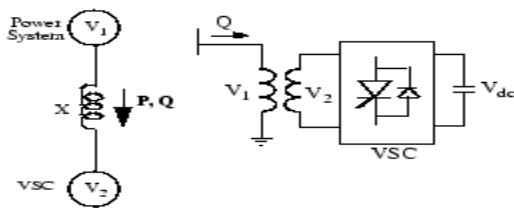

Fig.1.2: Operating Principle of the STATCOM

Fig.1.2 shows that The STATCOM Static Synchronous Compensator is one of the types of FACTS devices. Based on a voltage-sourced converter, the STATCOM regulates system voltage by generating or absorbing reactive power. Opposing to a thyristor-based STATCOM, Static Var Compensator (SVC), output current (inductive or capacitive) can be controlled independent of the AC system voltage. The power grid consists of two 400-kV equivalents (respectively 3000 MVA and 2500 MVA) connected by a 550-km, 50 Hz transmission line. When the STATCOM is not in operation, from bus B1 to B3 the "natural" power flow on the transmission line is 930 MW. The STATCOM is to be [2-5].found at the middle of the line (bus B2) and has a rating of +/- 100MVA. This STATCOM is a phasor model of a representative three-level PWM STATCOM. If you open the STATCOM dialog box and select "Display Power data", you will see that our model represent a STATCOM having a DC link insignificant voltage of 66 kV with an corresponding capacitance of 375 uF. On the AC side, its total corresponding impedance [6].is 0.22 pu on 100 MVA. This impedance represents the transformer leakage reactance and the phase reactor of the IGBT Bridge of an actual PWM STATCOM.

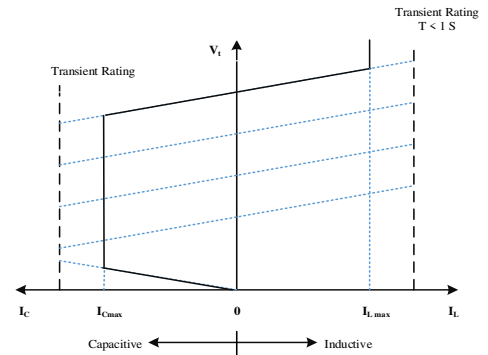

Fig. 1.3: V-I Characteristics of STATCOM

Fig.1.3 shows that Typical V-I characteristic of a STATCOM which operates both the capacitive and the inductive compensation and is capable to competition handle its output current over the rated maximum inductive or capacitive range irrespective of the quantity of ac-system voltage [7]. That is STATCOM can provide full capacitive-reactive power at any system voltage even as low as 0.15pu.

B) SVC Controller

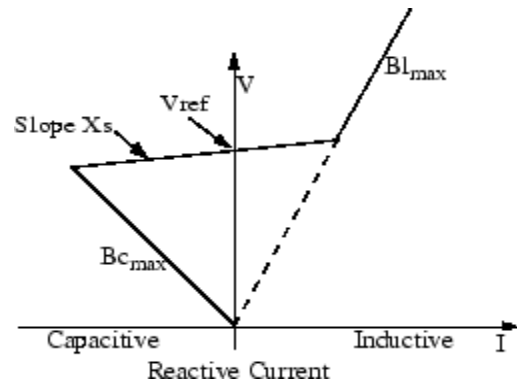

Fig.1.4: SVC V-I Characteristic

Fig.1.4 shows that The V-I Characteristic (SVC) Static Var Compensator is a shunt device of the Flexible AC Transmission Systems (FACTS) family of power electronics to control power flow and get better transient stability on power grids [1]. The SVC Static Var Compensator regulates voltage at its terminals by controlling the amount of reactive power absorbed into or injected from the power system. When system voltage is high, it absorbs reactive power (SVC inductive). When system voltage is low down, the SVC generates reactive power (SVC capacitive). The deviation in reactive power is performed by switching three-phase capacitor banks and inductor banks linked on the secondary side of a coupling transformer. Every capacitor bank is switched on and off by (TSC Thyristor Switched Capacitor) three thyristor switches. Reactors are either switched on-off (TSR Thyristor Switched Reactor) or phase-controlled (TCR Thyristor Controlled Reactor). The SVC can be operated in two special modes: in Var control mode (the SVC Susceptance is kept constant) when the SVC is operated in voltage regulation mode, in voltage regulation

mode as long as the SVC Susceptance B stays within the minimum and maximum [8]. Susceptance values forced by the total reactive power of reactor banks (B_{lmax}), and capacitor banks (B_{cmax}) the voltage is regulated at the reference voltage V_{ref} . Voltage droops (typically between 1% and 4% at maximum reactive power output), and V-I characteristic has the slope indicated in the figure 1.4 is described by the following three equations:

$$V = V_{Ref} + X_S \cdot I \quad \text{if SVC is in Regulation range}$$

$$= -\frac{I}{B_{cmax}} \quad \text{if SVC is Fully capacitive} \quad (1.1)$$

$$(B = B_{cmax}) \quad (1.2)$$

$$= \frac{I}{B_{cmax}} \quad \text{if SVC is Fully inductive}$$

$$(B = B_{lmax}) \quad (1.3)$$

Where

V = Positive Sequence Voltage (pu)

I = Reactive current (pu/Pbase) ($I > 0$ indicates an Inductive current)

X_s = Gradient or Droop Reactance (pu/Pbase)

B_{cmax} = Highest Capacitive Susceptance (pu/Pbase) with All TSCs in service, no TCR or TSR

B_{lmax} = Highest Inductive Susceptance (pu/Pbase) with all TSR's in service or no TSC, TCRs at full conduction.

II. SYSTEM MODELLING

The STATCOM consists of a three-phase pulse width modulated (PWM) voltage-source converter (VSC) [8-9] using insulated-gate bipolar transistors (IGBTs), three interface inductors and dc capacitor. The STATCOM injects currents into the point of common coupling in such a way so as to keep up balancing and harmonic elimination in the source currents. The VSI operation is supported by the dc storage capacitor with voltage across it. STATCOM and SVC FACTS Devices are connected in central point of 50 Hz transmission system. In that Simulation model two generators are connected both end regions. The three phase mutual inductance connected in series with the first generator. B1, B2 and B3 are used for measurement of current & voltage of transmission line. Simulink Model consists of the three phase distributed parameter line and three phase PI section line [8]. The three parallel loads are connecting with transmission line network that is 100MW, 2MW, 300MW. For creating fault in transmission line by manually we are also connected fault impedance. Once creating a fault the instability in transmission line can be compensated by STATCOM and SVC FACTS devices.

a) Dynamic Response of STATCOM

The dynamic responses of STATCOM in Matlab-model for 50 Hz that Unlock the STATCOM dialog box and choose

"Display Control parameters". Mode of operation is set to be "Voltage regulation" and External control of reference voltage " V_{ref} " also, the "droop" parameter should be set to 0.03 and the "Vac Regulator Gains" to (proportional gain K_p) 5 and (integral gain K_i) 1000. (The red timer block connected to the " V_{ref} " input of [8-9]. the STATCOM) Close the STATCOM dialog block and open the "Step V_{ref} " block. This block should be programmed to modify the voltage reference V_{ref} as follows: Initially V_{ref} is set to 1 pu; at $t=0.2$ s, V_{ref} is decreased to 0.97 pu; then at $t=0.4$ s, V_{ref} is increased to 1.03 pu; and finally at 0.6 s, V_{ref} is set back to 1 pu, but make sure that the fault breaker at bus B1 will not operates during the Simulation.

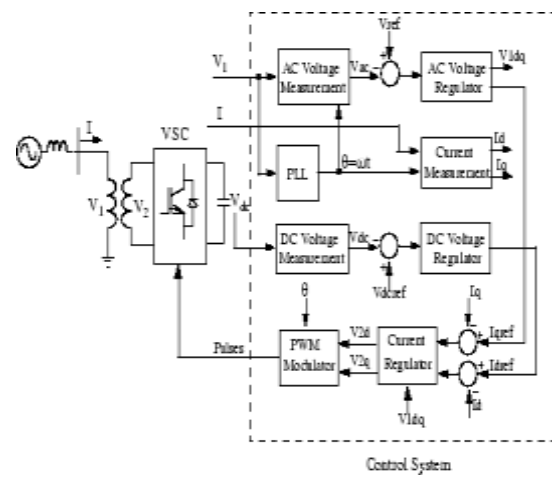

Fig.2.1: control Strategy of STATCOM Controller

Run the Simulation and look at the "VQ_STATCOM" scope. The fig. 3.3 displays the V_{ref} signal (magenta trace) along with the measured positive-sequence voltage V_m [11]. At the STATCOM bus (red trace). The signal Q_{ref} (magenta trace) is not relevant to our Simulation because the STATCOM is in "Voltage regulation" and not in "VAR Control" The fig.3.2 displays the reactive power Q_m (Blue trace) absorbed (positive value) or generated (negative value) by the STATCOM. The control method consists of a measurement system measuring the positive-sequence voltage to be controlled. A Fourier-based measurement system using a one-cycle operation average is used. A voltage regulator that uses the voltage error (difference between the reference voltage V_{ref} and the measured voltage V_m) to determine the SVC Susceptance B needed to keep the system voltage constant [7]. Distribution unit that determine the TSCs (and eventually TSRs) that must be switched ON and OFF and computes the firing angle α of TCRs. A synchronizing system using a PLL Phase-Locked Loop synchronized on the secondary voltages and a pulse generator that gives appropriate pulses to the Thyristors.

b) Dynamic Response of SVC

When the SVC is operating in voltage regulation mode, its response speed to a vary of system voltage depends on the voltage regulator gains (integral gain K_i and proportional gain K_p), the droop reactance X_s , and (short-circuit level) the system strength. for an integral-type ($K_p = 0$), voltage regulator if the voltage measurement time constant T_m and the average time delay T_d due to valve firing are neglect, the closed-loop[7].system consisting of the SVC and the power system can be approximated by a first-order system having the following closed-loop time constant:

$$T_{C=1/(K_i(X_s+X_n))} \quad (2.1)$$

Where T_c = Closed loop time constant

K_i = comparative gain of the voltage regulator
 (Pu_B/pu_V/s)

X_s = gradient reactance pu/P base

X_n = Equivalent power system reactance (pu/P base)

This equation demonstrates that we obtain a faster response speed when the system short-circuit level decreases (higher X_n values) or when the regulator gain is increased.

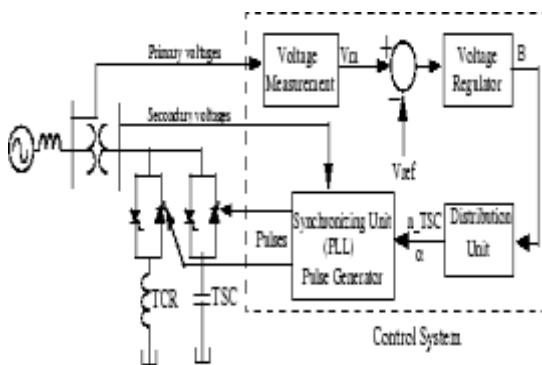

Fig.2.2: Block Diagram of an SVC and Its Control System

The SVC parameters are grouped in two categories: Power Data and Control Parameters. The block of SVC is a phasor model, it can be used in three-phase power systems together with synchronous motors, generators, and dynamic loads to [5-7].execute transient stability studies and examine impact of the SVC on electromechanical oscillations and transmission capability. These systems are approximated relatively by simple transfer functions that defer a correct representation at the system's fundamental frequency.

The (PLL) Phase Lock Loop closed-loop control system, which tracks the frequency and phase of a sinusoidal signal by using an inner frequency oscillator. The system adjusts the inner oscillator frequency to keep the phase's difference zero. The figure 2.3 shows that the internal diagram of the PLL.

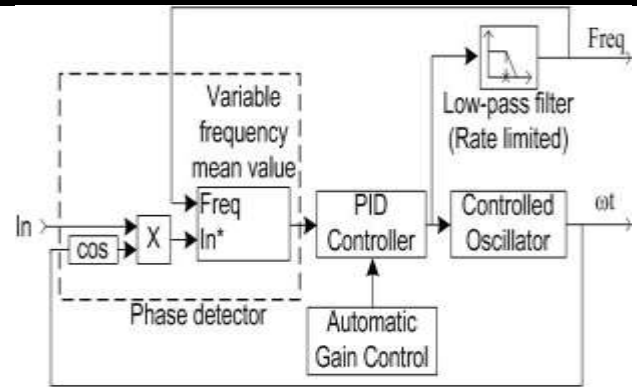

Fig 2.3: Block diagram of Phase Lock Loop (PLL)

The input signal is assorted with an internal oscillator signal. The DC component of the assorted signal (comparative to the phase difference between these two signals) is extracted with an unstable frequency mean value. A (PID) Proportional-Integral-Derivative controller [3].with an optional (AGC) automatic gain control keeps the phase difference to 0 by acting on a controlled oscillator. The PID output, consequent to the angular velocity, is filtered and improved to the frequency in Hz, which is used by the mean value.

The system terminal voltages are given as,

$$V_a = V_m \sin(\omega t) \quad (2.2)$$

$$V_b = V_m \sin(\omega t) - \frac{2\pi}{3} \quad (2.3)$$

$$V_c = V_m \sin(\omega t) + \frac{2\pi}{3} \quad (2.4)$$

Where, V_m is the peak amplitude and ωt angular frequency, respectively, of the system voltage at the PLL. [5].The amplitude of PLL voltage is calculated as,

$$V_t = \sqrt{\frac{2}{3} (V_a^2 + V_b^2 + V_c^2)} \quad (2.5)$$

a) VSC Based control Strategy: The VSC is designed for compensating a reactive power. There are lots of control schemes are available for control of shunt active compensators [9]. Such as instantaneous reactive power theory, power balance theory, synchronous reference frame theory, symmetrical components based etc. and the synchronous reference frame theory are used for the control of projected STATCOM. The load currents and the point of common coupling (PCC) [10] voltages and dc bus voltage of STATCOM are sensed as feedback signals to form a closed loop system. The load currents from the a-b-c frame are first converted to the a-b-c frame and then to the d-q-0 frame as,

$$\begin{bmatrix} I_{Ld} \\ I_{Lq} \\ I_{Lo} \end{bmatrix} = \frac{2}{3} \begin{bmatrix} \cos\theta & -\sin\theta & \frac{1}{2} \\ \cos\left(\theta - \frac{2\pi}{3}\right) & -\sin\left(\theta - \frac{2\pi}{3}\right) & \frac{1}{2} \\ \cos\left(\theta + \frac{2\pi}{3}\right) & \sin\left(\theta + \frac{2\pi}{3}\right) & \frac{1}{2} \end{bmatrix} \begin{bmatrix} I_{La} \\ I_{Lb} \\ I_{Lc} \end{bmatrix} \quad (2.6)$$

Where, $\cos\theta$, $\sin\theta$ are obtained using a three-phase PLL. The d-axis and q-axis currents consist of fundamental and harmonic components as,

$$I_{Ld} = I_{d\ dc} + I_{d\ ac} \quad (2.7)$$

$$I_{Lq} = I_{q\ dc} + I_{q\ ac} \quad (2.8)$$

b) PQ Theory: Using definition of the instantaneous reactive power theory for a balanced three phase three wire system, the quadrature component of the voltage is always zero, the real power (p) and the reactive power (q) [10-11] injected into the system by the STATCOM can be expressed under the d-q reference frame as,

$$p = V_d I_d + V_q I_q \quad (2.9.1)$$

$$q = V_q I_d - V_d I_q \quad (2.9.2)$$

Since $V_q=0$, I_d and I_q completely described the instantaneous value of real and reactive powers produced by the STATCOM when the system voltage remains constant. Therefore the instantaneous three phases current measured which is transformed by abc to dqo transformation. The main advantage of this scheme is that it incorporates a self-supporting dc bus.

III. SIMULATION RESULTS

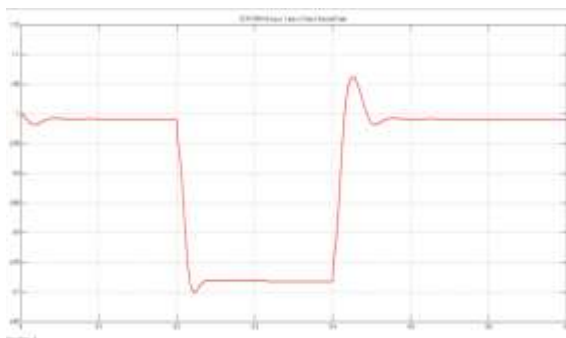

Fig.3.1: Dynamic Response of STATCOM (Vm)

Fig 3.1 shows that the Dynamic Response of STATCOM at initial stage of transmission line is inductive. Because of the inductive load, transmission line voltage decreases to desired value, to maintain the desired voltage level STATCOM act as capacitive (0-0.2 sec.).

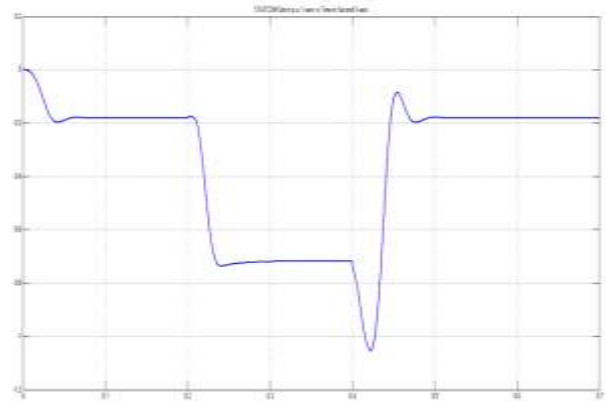

Fig.3.2: Dynamic Response of STATCOM (Qm)

Fig 3.2 shows that the instant 0.2 sec. Z-fault take placed and voltage falls down (0.2sec to 0.4 sec.) at that time STATCOM is operated as more capacitive and goes more negative to regulate voltage. at the instant 0.4 sec. fault is rapidly removed at that time STATCOM capture one overshoot and comes at desired level same as the before fault occur.

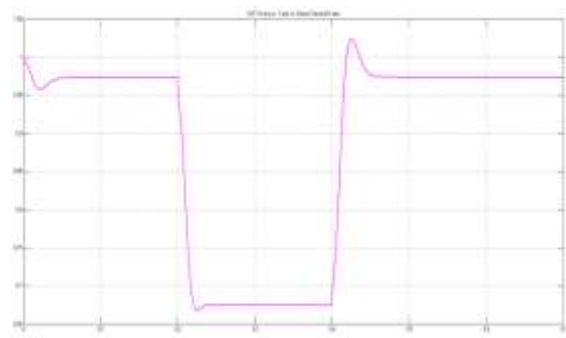

Fig.3.3: Dynamic Response of SVC (Vm)

Fig 3.3 shows that the Dynamic Response of SVC at initial stage of transmission line is inductive. Because of the inductive load, transmission line voltage decreases to desired value, to maintain the desired voltage level SVC act as Capacitive (0-0.2 sec.).

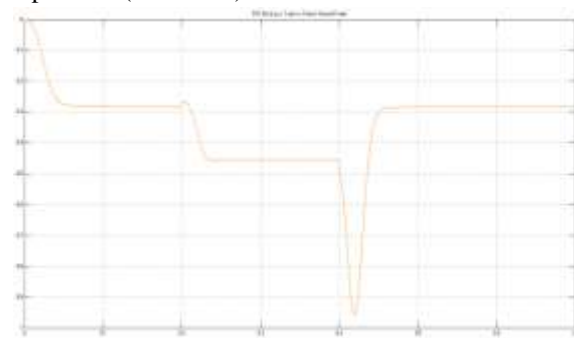

Fig.3.4: Dynamic Response of SVC (Qm)

Fig 3.4 shows that at the instant 0.2 Z-fault take placed and voltage falls down (0.2sec.to 0.4 sec.) at that time SVC is operated as more capacitive and goes more negative to regulate voltage. at the instant 0.4 sec. fault is rapidly

removed at that time SVC capture one overshoot and comes at desired level same as the before fault occur.

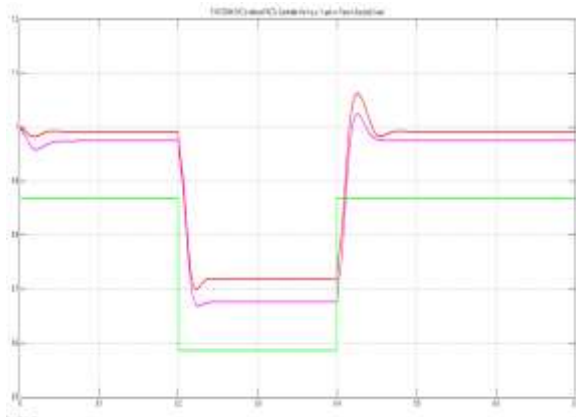

Fig.3.5: Voltage of STATCOM, SVC, without any Facts devices

The fig.3.5 displays the measured voltage V_m on both systems (magenta trace for the SVC), (red trace for STATCOM).at some stages in the 10-cycle fault, a key variations between the SVC and the STATCOM can be observed. The reactive power generated by the SVC is -0.48 pu and the reactive power generated by the STATCOM is -0.71 pu.

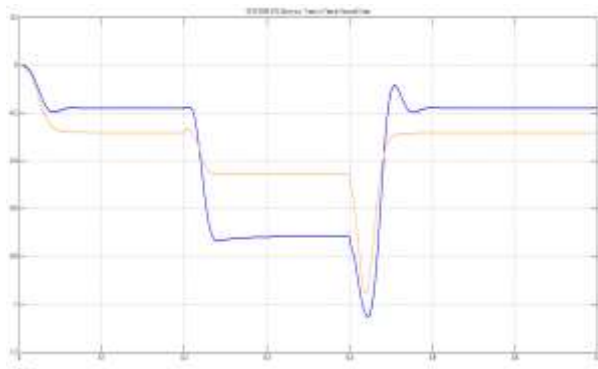

Fig.3.6: Reactive Power of STATCOM and SVC

The fig.3.6 shows that the measured reactive power Q_m on both systems (Blue trace for the STATCOM), (Orange trace for SVC).the upper limit capacitive power generated by a SVC is proportional to the square of the system voltage (constant Susceptance) while the upper limit capacitive [6-7].power generated by a STATCOM decreases linearly with voltage decrease (constant current).

Table.1: Comparison between Compensator

Compensator	TCR-TSC (SVC)	STATCOM
Type	Controlled Impedance	Synchronous Voltage Source
Losses	Low	Medium
Harmonic	Low	Very Low
Maximum Delay	1 Cycle	Withdraw

Transient Behavior Of System	Medium	Good
Maintenance Cost	Medium	Medium
Compensation Cost	Medium	High

IV. CONCLUSION

In proposed method Simulation results shows that without any FACTS device, the system is unstable (showing in Green line in fig 3.5) and after connecting FACTS controllers it becomes stable. Then it is clearly shows that the result of STATCOM is (shown in Red trace) better than SVC (shown in Magenta trace). In addition of FACTS controllers into power systems, to maintain the stability of the power system when the system load-ability is increases STATCOM generates reactive Power (Capacitive Mode) and when the system load-ability is decreases it absorb reactive Power (Inductive Mode). Transient Stability of power System with various load at various Buses improved using SVC Device.

REFERENCES

- [1] D. Murali, Dr. M. Rajaram, N. Reka, "Comparison of FACTS Devices for Power System Stability Enhancement," International Journal of Computer Applications (0975 – 8887) Volume 8– No.4, October 2010.
- [2] Christian Rehtanz, Senior Member, IEEE, Justin-Jin Zhangss, "New types of FACTS-devices for power system security and efficiency," 978-1-4244-2190, 9 July 2007.
- [3] R. L. Hauth, S. A. Miske, Jr., and F. Nozari, "The Role and Benefits of Static Var Systems in High Voltage Power System Applications," 82 WM 076-, p 3761, 8 October 1982.
- [4] K. Balamurugan, G. Suganya & N.Manojkumar "Improving Power System Dynamics by Series Connected FACT'S Controllers (TCSC)", International Conference on Power, Energy and Control (ICPEC) 978-1-4673-6030, IEEE, February 2013.
- [5] Dipti Mohanty, Aziz Ahamad and M. A. Khan, "Modeling, Simulation and Performance Analysis of FACTS Controller in Transmission line", International Journal of Emerging Technology and Advanced Engineering, ISSN 2250-2459, Volume 3, Issue 5, May 2013.
- [6] Raju Pandey and A. K. Kori, "Enhancement of Power Quality in Transmission Line Using Flexible Ac Transmission System", International Journal of Science, Engineering and Technology Research (IJSETR) Volume 2, Issue 8, August 2013.

- [7] Ms. Chitra Thakur and Mr. Saurabh Sahu, "Analysis Of Voltage Stability And Transfer Capability Enhancement Of Transmission System Using Facts Controllers", *Current Trends in Technology and Science* ISSN: 2279-0535. Volume: II, Issue: VI, 2013.
- [8] Impact of TCSC on the Protection of Transmission Lines Mojtaba Khederzadeh and Tarlochan S. Sidhu, Fellow, *IEEE Transactions On Power Delivery*, Vol. 21, No.1, January 2006.
- [9] Engr. Qazi Waqar Ali , Prof. Dr. Azzam ul Asar, "Smart Power Transmission System Using FACTS Device", *International Journal of Engineering & Computer Science IJECS-IJENS* Vol:12 No:06. December- 2012.
- [10] S. Fahad Bin Shakil, Nusrat Husain, "Improving the voltage stability and Performance of power networks using power Electronics based FACT controllers", *International Conference on Power System Technology*, 2006.
- [11] S.K. Das and J.K. Moharana, "Design, Analysis and Simulation of Small Signal Control Strategy of a STATCOM for Reactive Power Compensation on Variation of DC link Voltage", *International Conference on Power, Energy and Control (ICPEC)*, 2013.
- [12] Guentri Racine, Gherbi F.Z "The interest of FACTS to improve voltage and losses Reduction in the western Algerian network 2012", *IEEE 978-1-4673-6673-2015*.
- [13] A. B. Arsoy, Y. Liu, P. F. Ribeiro, & F. Wang, "Static-Synchronous Compensators And Superconducting Magnetic Energy Storage Systems In Controlling Power System Dynamics", *IEEE Industry Applications Magazine*, Mar-Apr 2003.
- [14] Arvind Pahade and Nitin Saxena, "Transient stability improvement by using shunt FACT device (STATCOM) with Reference Voltage Compensation (RVC) control scheme", *International Journal of Electrical, Electronics ISSN No. (Online), 2277-2626 and Computer Engineering* 2(1): 7- December 2013.