

Implementation of CQM on SSR Enhanced Images

C Bhargav, S Ahmed Basha, U Veeresh, K Prasad Babu

Department of ECE, SJ CET, Yemmiganur, Kurnool (Dist), Andhra Pradesh, India

Abstract— Image enhancement is one of the key issues in high quality pictures such as digital camera and HDTV. The image enhancement targets on transforming input image as better one, so that the enhanced image solve the purpose of specific application or set of objectives. Since image clarity is very easily affected by lighting, weather, or equipment that has been used to capture the image. These conditions lead to image may suffer from loss of information. As a result, many techniques have developed known as image enhancement techniques to recover the information in an image. Contrast Stretching, Histogram equalization is a primitive and well established technique for enhancing image contrast but cannot preserve the brightness and color of the original Image and Homomorphic filtering technique has the problem of bleaching of the image. Modern technique like Single Scale Retinex (SSR) performs much better than those listed above because it is based on the color constancy theory and white balancing. Peak Signal-to-Noise Ratio (PSNR) and Calculation of Quality Measurement(CQM) are the measurable parameters which are considered in this project.

Keywords— Calculation of Quality Measurement (CQM), Image Enhancement, Peak Signal-to-Noise Ratio (PSNR), Single Scale Retinex, White Balancing.

I. INTRODUCTION

Image enhancement is the process of adjusting digital images so that the results are more suitable for display or further image analysis. Image enhancement focuses on and Frequency domain. In spatial domain the image is modified i.e. pixel value of image & in frequency domain operation will be made on the Fourier transform of an image. processing an image in such a way that the processed image is more suitable than the original one for the specific application. The word “specific” has significance. It gives a clue that the results of such an operation are highly application dependent. In other words, an image enhancement technique that works well for X-ray topographic images may not work well for MR images. Although enhancement techniques differ according to application but they are broadly classified as two type: Spatial domain domain and Frequency domain.

In spatial domain the image is modified i.e. pixel value of image & in frequency domain operation will be made on the Fourier transform of an image.

Many techniques have developed known as image enhancement techniques to recover the information in an image. Contrast Stretching, Histogram equalization is a primitive and well established technique for enhancing image contrast but cannot preserve the brightness and color of the original Image and Homomorphic filtering technique has the problem of bleaching of the image. Single Scale Retinex(SSR) described here will manipulate at image pixel level and provides good illuminated and colored image as the output. Since it is based on color constancy theory and white balancing.

II. SSR COLOR IMAGE ENHANCEMENT

2.1 Single Scale Retinex:

The Retinex is an image enhancement algorithm that performs a nonlinear spatial spectral transform that provides both dynamic range compression and color consistency. The retinex is a number of class of centre surround function where each input value of the function is determine by the corresponding input value (centre) and its neighbourhood (surround).The input in retinex algorithm is an array of photoreceptor response for each location of the image.

In retinex class, the retinex centre is defined as each pixel value and the surround is Gaussian function. This is represented by:

$$R(x, y) = \log(I(x, y)) - \log[I(x, y) \times f(x, y)] \quad \text{--- (1)}$$

Where I: is the input image and R: is the retinex output image and f is the Gaussian filter is defined by:

$$f(x, y) = k \exp \left[-\frac{(x^2 + y^2)}{\sigma^2} \right] \quad \text{--- (2)}$$

Where σ the standard deviation of filter and k is is the normalization factor that keeps the area under the Gaussian curve. K is selected such that:

$$\iint f(x, y) dx dy = 1 \text{ --- --- (3)}$$

Where x & y are spatial coordinates.

2.1.1 SSR Color Image Enhancement:

Single Scale Retinex can be used in color image enhancement. The following is the block diagram for achieving good colored and contrasted image. In the block diagram first color image will be taken as the input and surround function will be obtained by convolving input image with Gaussian filter on every pixel. Fig 1 shows the block diagram

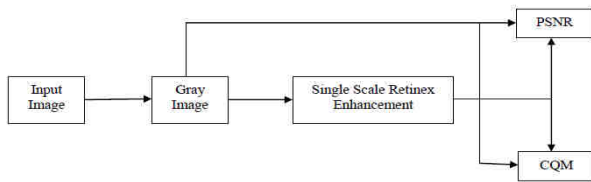

Fig 1: Block Diagram of SSR Enhancement

The output thus obtained will be given to PSNR and CQM blocks for calculations of values. As these values required input image hence the feedback path exists in the above block diagram. The following is the explanation of Peak Signal to Noise Ratio (PSNR) and Calculation of Quality Measurement(CQM).

III. PEAK SIGNAL TO NOISE RATIO

The Peak Signal to Noise Ratio (PSNR) measurement is used to evaluate a distorted image quality with respect to its original version as an error measure during experimental works. A computed PSNR value indicates the quality approximation between the distorted image and the original image. PSNR is standard of reconstructed image quality and is an important measurement feature. PSNR is defined as the ratio of maximum possible that can be obtained in an image to the mean square error (MSE).

$$PSNR = 10 \log \left[\frac{MAX^2}{MSE} \right] \text{ --- --- (4)}$$

Here, MAX is the peak value of the pixels in an image. MAX is 255 when pixels are presented in an 8-bit format. Mean square error (MSE) is defined as Where $M*N$ is the size of the original image. Higher the PSNR value is, better the reconstructed image is.

IV. CALCULATION OF QUALITY MEASUREMENT(CQM)

A test image is distorted by a wide variety of distortions, such as Gaussian, sharpen, salt & pepper, JPEG compression, median, and blurring, in order to examine the PSNR results for quality evaluations. Although the

test image is exposed to different types of distortion, the obtained PSNR results can be the same, and thus its use in a genuine evaluation is not feasible. This implies that the PSNR parameter solely does not enable distinguishing results for all of the probable cases. As a result, the PSNR for image quality assessment can be used easily, but cannot be adequate alone for a statistical visual evaluation.

4.1 CQM Calculation:

The CQM is obtained as shown in fig 2. At first, an original RGB image and its output image are transformed to the YUV images by employing the equations explained in this sections. Next, the PSNR quality of each YUV channel (Y, U, and V) is calculated separately.

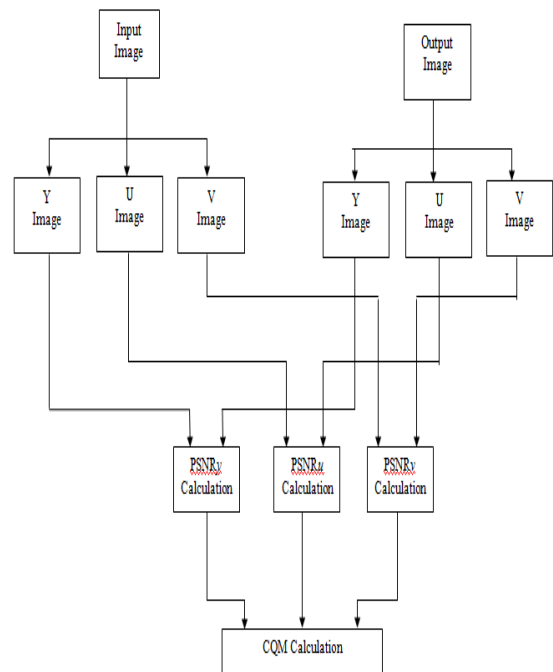

Fig 2: Block Diagram of CQM Calculation

Color transformation is usually used as a preprocess before the intracomponent coding in RGB color image compression . A commonly preferred color transformation is from RGB to YUV .YUV was originally adopted from the JPEG and JPEG2000 standards .

$$Y = 0.257R + 0.504G + 0.098B + 16 \text{ --- --- (5a)}$$

$$U = -0.148R - 0.291G + 0.439B + 128 \text{ --- --- (5b)}$$

$$V = 0.439R - 0.368G - 0.071B + 128 \text{ --- --- (5c)}$$

At the last step, the CQM value is calculated using Eq. (6)

$$CQM = (PSNRy \times R_w) + \left(\frac{PSNRu + PSNRv}{2} \right) \times C_w \quad \text{---(6)}$$

where the CQM is composed of our new discovery of the weighted luminance quality measure ($PSNRy \times R_w$) and weighted color quality measure ($(PSNRu + PSNRv) / 2 \times C_w$) components. The inclusion of this new weighted approach, considering the human eye's different responses to luminance and color, leads to the superiority of the proposed CQM measure over the classical PSNR-based image quality evaluations.

The weights on the human perception of these cone and rod sensors (i.e. C_w and R_w) are calculated below:

$$C_w = \frac{7,000,000}{(7,000,000 + 120,000,000)} = 0.0551 \quad \text{--- (7)}$$

$$R_w = \frac{120,000,000}{(120,000,000 + 7,000,000)} = 0.9449 \quad \text{--- (8)}$$

The 1st term, C_w , as seen in Eq. (7), is the weight on the human perception of the cones, and the 2nd term, R_w as seen in Eq. (8), is the weight on the human perception of the rods. Differing from the classical PSNR approach, the proposed CQM outstandingly considers this natural fact to consequently enable the obtaining of more accurate and differentiating image quality results.

V. RESULTS

Fig 3 shows an input image selected from the popup menu in the axes after clicking on 'Show Image' push button. Here need arises to concentrate on color and brightness in the input image so that it can be differentiated with output image.

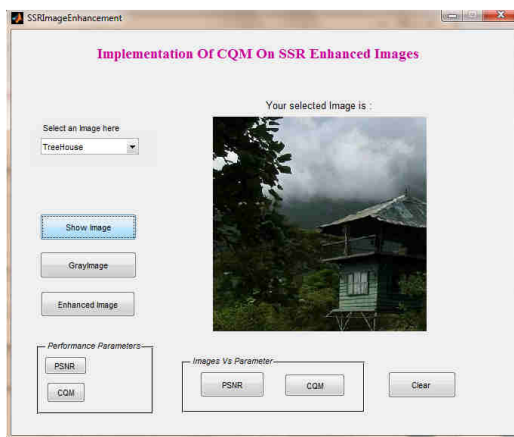

Fig.3: GUI Showing an input image in the axes

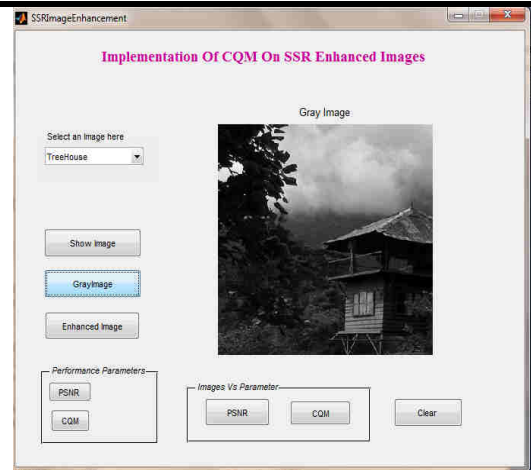

Fig .4: GUI Showing gray image

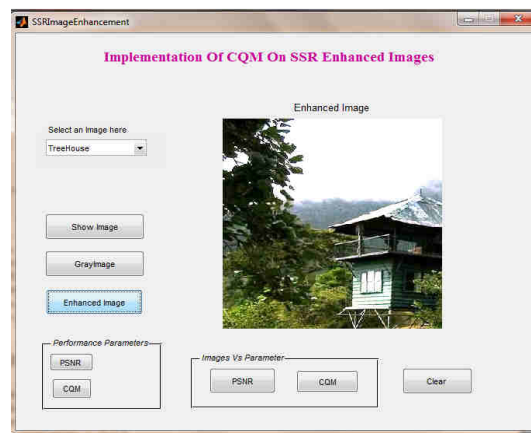

Fig.5: GUI Showing output image

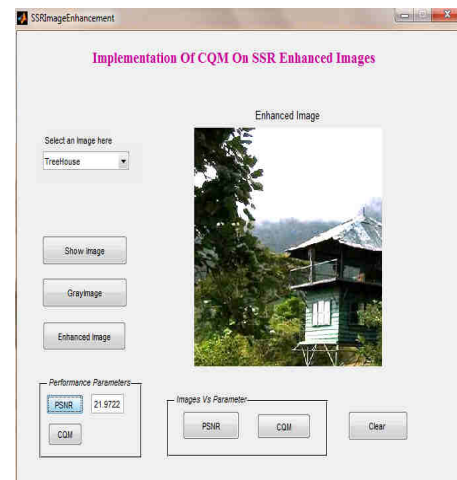

Fig.6: GUI Showing Peak Signal to Noise Ratio value

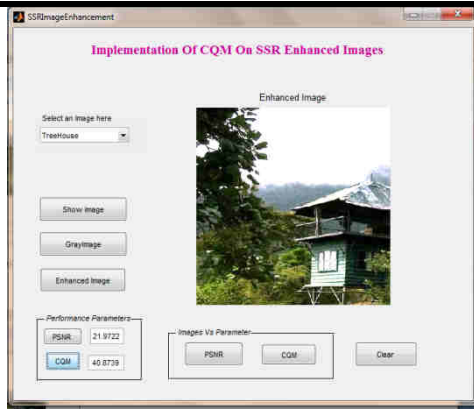

Fig.7: GUI Showing CQM value

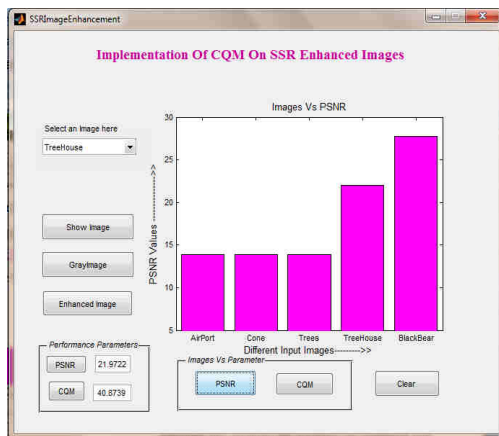

Fig.8: GUI Showing Bar Graph of PSNR values of different input images

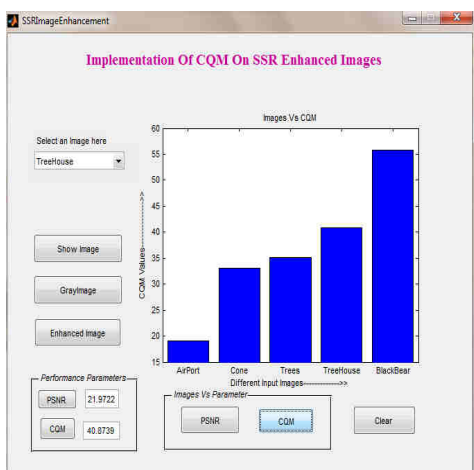

Fig 9: GUI Showing Bar Graph of CQM values of different input images

Fig 6 & Fig 7 shows PSNR and CQM values of 21.9722 and 40.8739 for the image ‘TreeHouse.jpg’. Fig 8 shows that for first three input images (Airport.jpg, Cone.jpg and Trees.jpg) the PSNR values remains same and hence creates ambiguity. Fig 9 shows though PSNR for the first three images remains constant the corresponding CQM is not. Trees.jpg is of higher CQM among the first three.

Hence CQM helps in image quality analysis when situation like this arises.

VI. CONCLUSION

As the measurement of quality of SSR enhanced images, here parameters like Peak Signal-to-Noise Ratio (PSNR) and Calculation of Quality Measurement (CQM) have been considered. To some images Peak Signal-to-Noise Ratio is same but Calculation of Quality Measurement (CQM) is different. Hence based on this, it can state that for same PSNR images it is ambiguous to judge a qualitative image. In that case, the parameter like CQM is more useful.

REFERENCES

- [1] <https://sisu.ut.ee/imageprocessing/book/5>.
- [2] <http://homepages.inf.ed.ac.uk/rbf/HIPR2/stretch.htm>.
- [3] Histogram Equalization Techniques For Image Enhancement- Rajesh Garg, Bhawna Mittal, Sheetal Garg, IJECT Vol. 2, Issue 1, March 2011 https://en.wikipedia.org/wiki/Homomorphic_filtering.
- [4] https://en.wikipedia.org/wiki/Homomorphic_filtering
- [5] https://en.wikipedia.org/wiki/Color_constancy.
- [6] <http://homepages.inf.ed.ac.uk/rbf/HIPR2/gryimage.htm>
- [7] Comparative Study of Image Enhancement Techniques, Ms.Seema Rajput , Prof.S.R.Suralkar, IJCSMC, Vol. 2, Issue. 1, January 2013, pg.11 – 21
- [8] Review Of Image Enhancement Techniques Using Histogram Equalization, IJAEM, Volume 2, Issue 5, May 2013 ISSN 2319 – 4847.
- [9] Implementing Histogram Equalization and Retinex Algorithms for Image Contrast Enhancement, Middle-East Journal of Scientific Research 22 (10): 1457-1461, 2014, ISSN 1990-9233, IDOSI Publications, 2014 DOI:10.5829/idosi.mejsr.2014.22.10.21448
- [10] A new color image quality measure based on YUV transformation and PSNR for human vision system, Turkish Journal of Electrical Engineering & Computer Sciences