

Maternal Employment Status, Ethnicity, Food Intake, and Their Effects on Teenage Obesity, in Surakarta

Rahmah Purwaningsih Febri Susanti¹⁾, Bhisma Murti¹⁾, Dono Indarto²⁾

¹⁾Masters Program in Public Health, Universitas Sebelas Maret

²⁾ Faculty of Medicine, Universitas Sebelas Maret

ABSTRACT

Background: Obesity is one of the main causes of premature death in adulthood. The prevalence of teenage obesity in Indonesia has been increasing from 1.4% in 2007 to 7.3%. It is hypothesized that the risk of obesity is influenced by lifestyle and socio-economic status. This study aimed to determine the effect of maternal job status, ethnicity, and food intake, on the risk of obesity in teenagers.

Subjects and Method: This was an analytical observational using case-control design. This study was conducted in Surakarta, in September – November 2016. A total of 120 teenagers were selected for the study, consisting of 41 obese teenagers aged 16-18 years old and 79 normal weight teenagers, using fixed disease sampling. The dependent variable was obesity. The independent variables were maternal employment status, ethnicity, carbohydrate intake, fat intake, and energy intake. The data were collected using a set of questionnaires. Food intake was measured by 24 hour food recall. The data were analyzed using path analysis model.

Results: Energy intake had positive, significant, and direct effect on the risk of teenage obesity ($b=6.75$; 95%CI= 4.36 to 9.14; $p<0.001$). Working mother indirectly had positive and significant effect on teenage obesity, via fat intake ($b=0.77$; 95% CI= 0.03 to 1.52; $p=0.040$). Fat intake indirectly had positive and significant effect on teenage obesity, via energy intake ($b=4.16$; 95%CI=1.95 to 6.38; $p=0.001$). Likewise, carbohydrate intake had positive and significant effect on teenage obesity, via energy intake($b=3.31$; 95% CI=1.73 to 4.88; $p=0.001$). Ethnicity (Chinese versus Javanese) did not have significant effect on teenage obesity ($b=-1.14$; 95% CI =-3.56 to 1.28; $p=0.355$).

Conclusion: Energy intake has direct effect on the risk of teenage obesity. Fat intake, carbohydrate intake, and maternal employment status, have indirect effect on the risk of teenage obesity.

Keywords: maternal employment status, ethnicity, food intake, obesity, teenager.

Correspondence :

Rahmah Purwaningsih Febri Susanti. Masters Program in Public Health, Universitas Sebelas Maret, Jl. Ir. Sutami No. 36 A, 57126, Surakarta, Central Java. Email: rahmahpfs77@gmail.com

BACKGROUND

Obesity and its association with various comorbidities have become serious threat for global health (Finucane et al., 2011). Obesity is the major cause of the occurrence of cardiovascular diseases (Ahima, 2016). Obesity and overweight generate the major risk for serious chronic disease, and they are related to 40 chronic diseases (ASMBS, 2013). Obesity and overweight cause about 80% of type 2 diabetes mellitus, about 35%

of ischemic heart disease, 55% of hypertension disease, 1 million deaths and 12 million of morbidity rate each year (WHO Europe, 2007). Obesity increases the risk of early death by 5-10% compares to individual with normal weight and associated with cancer disease (ASMBS, 2013).

Adolescents with obesity will be easier to suffer from cardiovascular diseases and pre diabetes. Obese children and adolescents have bigger risk to endure problems

on bone, joints, as well as respiratory failure. Obese children and adolescents with are more vulnerable to social and psychological problems, such as stigmatization, poor self esteem from society (Li et al., 2009; CDC, 2011; Ahima, 2016).

Increasing obesity cases on children and adolescents is equal to the cases on adults. Prevalence which is likely to increase on children as well as adolescents is a warning for government and society toward the implication of obesity (Sartika, 2011). Adult Treatment Panel (ATP-III) of National Cholesterol Education Program (NCEP) suggests the reduction of body mass index as primary prevention of cardiovascular diseases (Ahima, 2016).

It is important to concern about obesity on adolescents since it is 80% at risk to stay remain until adulthood. Overweight and obesity on children and adolescents generates morbidity and premature mortality in adulthood (Reilly and Kelly, 2011; Strand et al., 2012). 70% obesity on adolescents is at risk for at least one risk factor of cardiovascular diseases during childhood (Freedman et al., 2007). Obesity that stay until adulthood will generate the emergence of several degenerative diseases, therefore it needs to conduct early preventive effort toward overweight and obesity (Octari et al., 2014).

WHO data showed that obesity around the world has been increasing twice since 1980. In 2014 more than 1.9 billion (39%) adults aged 18 years above suffered from overweight with 600 million (13%) among them are obese (WHO, 2015). United States as the country with the highest rank of obesity has obesity prevalence as big as 35.3% of the population of 15 years old and above (OECD, 2014). Indonesia ranks the tenth of the countries with the highest obesity level in the world (BBC, 2014). Obesity prevalence on adolescents

(2013) age group of 16 – 18 was 7.3% (5.7% overweight and 1.6% obesity), it increased by 5.9% from 1.4% in 2007. The overweight and obesity prevalence in Central Java for age 16-18 years was 5.4% and 1.7%. Surakarta is a city with the highest overweight and obesity prevalence among adolescents (16-18 years) in Central Java which is 12.3% (6.4% overweight and 5.9% obesity) (Balitbang Kemenkes, 2013).

The escalating obesity prevalence is generated by the consumption pattern of high calorie and fat as well as lack of physical activity (WHO, 2003; Anastase and Nathalie, 2014; Little et al., 2016). Obesity in urban area is higher than obesity in rural area (Pradeepa et al., 2015). Maternal education and occupation also play important roles in teenage obesity (Abuya et al., 2011; Lamerz et al., 2005; Akbari et al., 2007).

SUBJECTS AND METHOD

The study was analytic observational study with case control approach. The study was conducted in October 2016 in SMA Negeri 6 and SMA Regina Pacis, Surakarta. A sample of 120 students consisting of 41 obese students and 79 students with normal body weight was selected by fixed disease sampling. The data were collected by questionnaires and interview. Food intake data were collected by using 24 hour food recall. The data were analyzed by path analysis.

RESULT

1. Study Subjects Characteristics

Characteristics of the study subjects (Table 1) showed that there is no different pattern on various characteristics except for maternal employment status. Obesity cases showed equal proportion between male and female (48.8% and 51.2% respectively).

However in control group, male (39.2%) was outnumbered by female (60.8%).

Table 1. Distribution of Study Subjects

Characteristics	Obesity (case)		Normal (control)	
	n	%	n	%
Sex category				
Male	20	48.8	31	39.2
Female	21	51.2	48	60.8
Ethnicity				
Javanese	32	78	55	69.6
Chinese	9	22	24	30.4
Age (years)				
16	22	53.7	39	49.4
17	18	43.9	33	41.8
18	1	2.4	7	8.9
Systolic Blood Pressure (mmHg)				
<120	30	73.2	79	100
≥120	11	26.8	0	0
Diastolic Blood Pressure (mmHg)				
<80	27	65.9	75	94.9
≥80	14	34.1	4	5.1
Paternal education				
Elementary School	0	0	4	5.1
Junior High School	3	7.3	2	2.5
Senior High School	14	34.1	33	41.8
Associate's Degree	1	2.4	0	0
Bachelor's Degree	16	39	29	36.7
Master's Degree	7	17.1	11	13.9
Maternal education				
Elementary School	1	2.4	2	2.5
Junior High School	4	9.8	5	6.3
Senior High School	16	39	32	40.5
Associate's Degree	0	0	3	3.8
Bachelor's Degree	18	43.9	33	41.8
Master's Degree	2	4.9	4	5.1
Maternal Employment Status				
Employed	24	58.5	31	39.2
Stay at home mothers	17	41.5	48	60.8
Family Income (Rupiah)				
≥ 3,500,000	22	53.7	44	55.7
< 3,500,000	19	46.3	35	44.3

Based on ethnicity, the study subjects were dominated by Javanese ethnicity both in case and control group (78% and 69.6% respectively). The age of study subjects was dominated by 16 years of age, both in case and control group (53.7% and 49.4% respectively). Systolic blood pressure of the study subjects was dominated by normal blood pressure (<120 mmHg) both in case and control group (73.2% and 100% respectively). The majority of diastole blood

pressure of study subjects was also normal (≤80 mmHg) both in case and control group (65.9% and 94.9% respectively). It happened since the study subjects were still young at age (16-18 years old).

Parental education of the study subjects both in case and control group was dominated by high educational level (Senior High School and Bachelor's degree). It happened because the study subjects' parents resided in Surakarta

which is a city of education center in former residency of Surakarta therefore they were aware on the importance of education. In obesity group maternal employment status was dominated by working mothers (58.5%), whereas control group was dominated by stay at home mothers (house-

wives) which was 60.8%. Income level of both case and control group were almost similar, whereas the family income of the study subjects was dominated by very high income (\geq Rp 3,500,000) both in case and control group which were 53.7% and 55.7% respectively.

Table 2. The Average of Fat Intake of Study Subjects

Characteristics	Obesity (case)		Normal (control)	
	n	%	n	%
Energy Intake*				
Sufficient	4	9.8	78	98.7
High	41	90.2	1	1.3
Carbohydrate*				
Sufficient	6	14.6	76	96.2
High	35	85.4	3	3.8
Protein Intake*				
Sufficient	1	2.4	14	17.7
High	40	97.6	65	82.3
Fat Intake*				
Sufficient	1	2.4	70	88.6
High	40	97.6	9	11.4

*Fat intake classification based on WNPG, 2004.

Table 2 showed that there was no different food intake pattern on case group (obesity) and control group (normal). Food intake pattern showed that case group (obesity) was dominated by high food intake, whereas on control group (normal body weight) was dominated by sufficient food intake.

2. Path Analysis

a. Model Specification

The initial model in path analysis could be observed in Figure 1.

b. Model Identification

There were a total of 6 measured variables, including 3 endogenous variables, and 3 exogenous variables, with a total of 5 parameters. Degree of freedom (df) = (number of measured variables x (number of measured variables + 1) / 2 - (endogenous variables + exogenous variables + number of parameter) = (6x7)/2 - (3+3+5) = 10.

Model identification on path analysis discovered the value of df was *over iden-*

tified (df>0) which meant path analysis was possible to do.

c. Model Fit and Parameter Estimation

Path analysis model made by researcher based on theory was checked/ tested for its fitness with the best model of variables association.

Figure 1 showed the result of path analysis between obesity and risk factors by STATA 13. The association between obesity and risk factor was shown by the value of variable coefficient on each path. From the model fit and estimation stage, it found variable coefficient as follow: (1) there was negative association of -1.1 between ethnicity and obesity, (2) there was positive association of 0.78 between maternal employment status and fat intake, (3) the positive association of 4.2 between fat intake and energy intake, (4) there was positive association of 3.3 between carbohydrate intake and energy intake, there was

psitif association of 6.8 between energy intake and nutrition intake.

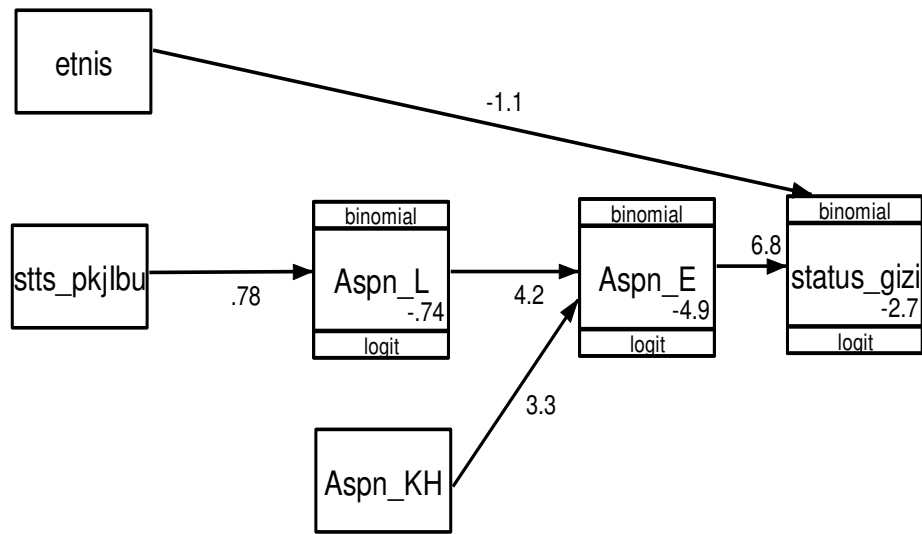

Figure 1. Model fit and parameter estimation

Table 3. Result of path analysis on teenage obesity risk factors

Dependent Variable	Independent Variables	b	CI 95%		p
			Lower Limit	Upper Limit	
Direct effect					
Nutritional Status	← Ethnicity (Chinese)	-1.14	-3.56	1.28	0.355
	← Energy Intake(>100%E)	6.75	4.36	9.14	<0.001
Indirect effect					
Fat intake	← Maternal Employment Status (employed)	0.77	0.03	1.52	0.040
Energy intake	← Fat intake (>25%E)	4.16	1.95	6.38	<0.001
	← Carbohydrate intake (>100%E)	3.31	1.73	4.88	<0.001
N Observation= 120					
Log likelihood = -121.2206					
AIC = 258.4412					
BIC = 280.7411					
← = associated					

Table 3 showed the result of data analysis by using STATA 13. There was association between ethnicity and reduction of risk logit of teenage obesity, however the association was statistically insignificant therefore it was not reliable. Teenagers with Chinese ethnicity had 1.14 lower obesity risk than teenagers with Javanese ethnicity (b= -1.14; CI 95%= -3.56 up to 1.28; p= 0.355).

There was association between energy intake and the increasing of risk logit of

teenage obesity, and it was statistically significant therefore the finding was reliable. Teenagers with high energy intake (≥100% Energy Adequacy Ratio) had 6.75 higher obesity risk logit than teenagers with sufficient energy (<100% Energy Adequacy Ratio) (b=6.75; CI 95%= 4.36 up to 9.14; p<0.001).

There was association between maternal employment status and increasing of teenager fat intake logit, and it was statistically significant. Working mothers who

worked outside the house had 0.77 higher teenage obesity risk logit than stay at home mothers (housewives) ($b = 0.77$; CI 95% = 0.03 up to 1.52; $p = 0.040$).

There was association between fat intake and increasing of teenager energy intake logit, and it was statistically significant. Teenagers with high fat intake ($\geq 25\%$ Energy Adequacy Ratio) had 4.16 higher high energy intake logit than teenagers with sufficient fat ($< 25\%$ Energy Adequacy Ratio) ($b = 4.16$; CI 95% = 1.95 up to 6.38; $p < 0.001$).

There was association between carbohydrate intake and increasing of teenager energy intake, and it was significant. Teenagers with high carbohydrate intake ($\geq 100\%$ Energy Adequacy Ratio) had 3.31 higher high energy intake logit than teenagers with sufficient carbohydrate ($< 100\%$ Energy Adequacy Ratio) ($b = 3.31$; CI 95% = 1.73 up to 4.88; $p < 0.001$).

d. Model Re-specification

Model in the study was in accordance already with data sample, as it was presented by saturation model and also regression coefficient that valued beyond zero and also was statistically significant, therefore it did not need to re-built another path analysis model.

Discussion

1. Association between ethnicity and teenage obesity

Fatness and obesity rate varied in various races and ethnicities represents interaction of various genes, social classes, cultures and customs that are locally specific in nature (Burhanet al., 2009). The result of the study showed that teenagers with Chinese ethnicity had 1.14 point lower average obesity logodd than teenagers with Javanese ethnicity. It showed that Chinese ethnicity reduced the risk for obesity (negative association). Statistically the

result was not significant therefore the finding was not reliable (path coefficient = -1.14; CI 95% = -3.56 up to 1.28; $p = < 0.355$).

According to NHANES 1999-2000 showed that overweight and obesity prevalence on male is a little varied if it is associated with race/ ethnicity, however from the data it is discovered that there is no reported significant different.

The result of the study was in accordance with the statement of Hill et al., (2006) that stated that differences among races and ethnicity may be discovered after controlling by using social economy factor. In the study social economy factor was also controlled by the researchers, among others were parental education and family income, therefore it found the effect of ethnicity toward obesity, which was Chinese ethnicity lower down the risk for obesity. Various ethnicity group indicates the differences on character and the amount of consumed food which will affect the total calorie intake, meal time and frequency, and the use of spices. Ethnicity also affects the use of oil and fat as well as primary food source such as staple food such as rice, wheat, and others (Goldstein, 2005).

It is in accordance with the result of the study that showed that food intake between Chinese ethnicity and Javanese ethnicity is different. The finding on study data indicated that less study subjects with Chinese ethnicity who had high energy, high fat and high carbohydrate intake, with a total of 27.3% of Chinese ethnicity had high energy intake (33.3% on Javanese ethnicity), 36.4% with high fat intake (42.5% on Javanese), and 30.3% with high carbohydrate intake (32.2% on Javanese) (refer to table 4 for the data). It might be the reason for Chinese ethnicity had smaller risk for obesity than Javanese ethnicity.

2. Association between energy intake and teenage obesity

The result of the study showed that teenagers with high energy intake (>100% EAR) had 6.75 higher point of average obesity *log odd* than teenagers with sufficient energy intake. It showed that high energy intake would increase the risk for obesity.

High energy intake (exceeding body needs for energy) that generates disproportion between energy intake and energy expenditure. As the result the excessive

energy will then be stored in a form of fat tissue thus will increase the risk for obesity. The energy excess may be generated by high energy intake or low energy expenditure. High energy intake is caused by excessive food consumption, whereas low energy expenditure is caused by the low metabolism, physical activity, and thermogenesis effect of food which is determined by food composition (IDAI, 2014). Statistically the result of the study was significant therefore it is reliable ($b=6.75$; $CI\ 95\%=4.36$ up to 9.14 ; $p<0.001$).

Table 4. Energy, fat, carbohydrate intake on Javanese and Chinese ethnicity

Characteristics	Javanese		Chinese	
	n	%	n	%
Energy Intake				
Sufficient	58	66.7	24	77.7
High	29	33.3	9	27.3
Carbohydrate Intake				
Sufficient	59	67.8	23	69.7
High	28	32.2	10	30.3
Fat Intake*				
Sufficient	50	57.5	21	63.6
High	37	42.5	12	36.4

The result of the study is in accordance with a study by Swinburn et al., (2004) which conveyed that high energy intake and high sedentary life style increases the risk for obesity. The result of the study is in line with a study conducted by Simatupang (2008) in Medan that stated that high energy intake increased the risk for obesity on children by 13 times compared to children who consume sufficient energy ($OR=13.15$; $CI\ 95\%=1.07$ to 162.11 ; $p=0.044$).

The result of the study is supported by statement from Musaiger (2004) which stated that consumption pattern and eating habits in East Mediterranean are undergoing changes in the last four decades, such as the increasing of energy and fat intake per capita almost all over the country and leads to the increasing of risk for obesity occurrence in the area. Changes are marked

by the shifting from the habit of eating traditional food to western-style food.

According to Almatier (2010) nutrients that can produce energy are carbohydrate, fat and protein. Oxidation of the nutrients results energy that is needed to do activities. Fat gives lower thermogenesis effect (3% of the total energy produced by fat) compares to carbohydrate (6-7% of the total energy produced by carbohydrate) and protein (25% of the total energy produced by protein) (IDAI, 2014).

The elaboration above is in line with the result of the study that showed there were association between fat, carbohydrate, and protein intake with energy intake. Teenagers with high fat intake (>25% of total EAR) had 4.01 point higher average *log odd* of energy intake compared to teenagers with sufficient fat intake ($\leq 25\%$ of total EAR). It showed that high fat intake

would increase energy intake (positive association). Statistically the association was significant, therefore the finding was reliable and there was association ($b=4.16$; CI 95%= 1.95 to 6.38; $p<0.001$).

Another result discovered during the study that high carbohydrate intake increased energy intake that later lead to obesity. The association between carbohydrate intake and energy intake through path analysis was discovered as positive association. The study showed that teenagers with high carbohydrate intake (>60% of total EAR) had 3.31 point higher log odd of energy intake compared to teenagers with sufficient carbohydrate intake ($\leq 60\%$ of total EAR).

It showed that high carbohydrate intake would increase energy intake (positive association). Statistically the association was significant therefore the finding was reliable ($b=3.31$; CI 95%=1.73 up to 4.88; $p<0.001$). The result of the study was in line with the study conducted by Vertikal (2012), on the association of physical activities, energy intake, and fat intake toward overnutrition. The result of the study showed that energy and fat intake increase the risk for the occurrence of over nutrition. The study is also in line with a study by Simatupang (2008) which showed that the energy, fat and protein intake increase the risk for obesity. The result of the study also showed that compares to high intake of protein and energy, high fat intake had the biggest effect toward the increasing risk for obesity as much as 61 times (OR= 61.32; CI 95%=3.86 up to 974.01; $p=0.004$).

According to Reaven (1997) to address the the effect of carbohydrate and fat within the body weight is by focusing the study on the variation of macro with energy intake. Various results of the studies show that the total of energy generates body weight change, without considering the

components of macro nutrients. The conclusion of the study shows that high fat diet increase the risk for body weight gain with high energy intake as the mediator.

Fat consumption generates the increasing energy intake that may lead to overnutrition. It is because fat contains twice as much energy than carbohydrate and protein. Moreover high fat food tastes more delicious that low fat food that it encourages people to eat excessively. Even though the energy content of fat is high however it gives small effect to the volume of gastrointestinal and the sense of bloated. The statement also supports that one person is able to consume big amount of fatty food (Atkinson, 2005).

Read and Kouris (1997) states that the occurrence of excessive fat intake from food consumption is changed into body fat intensively (97%) which means that to store the excessive fat into body fat only takes little energy.

The result of the study also showed that maternal employment status affected the obesity through fat intake. The study showed that mothers who work outside had 0.77 point higher average log odd of fat intake than work at home mothers (housewives).

It showed that working mothers increase the risk for obesity on teenagers (positive association). It can happen since working-outside mothers will spend most of their time at working places therefore they smaller chances to prepare food intake for their family than work at home mothers (housewives). Work at home mothers (housewives) are more possible to cook and serve food for the family by themselves, thus they are able to select and provide healthy and low fat food for their family. Working mothers had bigger possibility to buy fast food and provide less vegetables and fruits for family meal. Statistically the

finding was significant, and it was reliable ($b=0.77$; 95% CI= 0.03 to 1.52; $p=0.040$).

The result of the study is in line with a study made in Korea. Mothers who worked less than 40 hours/ week increased the risk for obesity by 4.23 times on male teenagers of 13-18 years old. While female teenagers of 6-12 years old were 1.15 times at risk for obesity on mothers who worked between 49-60 hours/week and female teenagers of 13-18 were 1.90 times at risk for obesity on mothers who worked 60 hours/week (Lee and Kim, 2013).

Lee and Kim (2013) states that working mothers are very likely to go for work at very early that they miss their children's breakfast and cannot accompany during breakfast time. Working mothers may also miss lunch or dinner. Therefore teenagers independently select and determine their own food to eat without mothers' assistance. Consideration in selecting food is more likely to be the taste, not the benefits nor the needs thus teenagers are likely to select high cholesterol food that taste more delicious compares to other food, that indirectly it increase the risk for teenage obesity (Lee and Kim, 2013).

Based on the elaboration above, a conclusion is found that ethnicity and energy intake directly associate and increase the risk for teenage obesity. Maternal employment status indirectly associates and increase the risk for teenage obesity through fat intake. Fat and carbohydrate intake indirectly associate and increase the risk for teenage obesity through high energy intake.

REFERENCES

- Ahima RS (2016). *Metabolic Syndrome A Comprehensive Textbook*. Switzerland: Springer international publishing.
- Almatsier S (2010). *Prinsip Dasar Ilmu Gizi*. Jakarta: Gramedia Pustaka Utama.
- ASMBS (2013). *Obesity in America*. www.asmbs.org diakses pada 15 Mei 2016.
- Balitbang Kemenkes (2013). *Pokok-pokok Hasil Riskesdas 2013 Provinsi Jawa Tengah*. www.litbang.depkes.go.id diakses pada 6 Juni 2016.
- BBC(2014). *Teenage Pressure Body Image and Weight*. www.bbc.co.uk diakses tanggal 15 Mei 2016.
- Burhan FZ, Sirajuddin S, Indriasari R (2009). Pola konsumsi terhadap kejadian obesitas sentral pada Pegawai pemerintahan di kantor bupati kabupaten Jeneponto. Program Studi Ilmu Gizi Fakultas Kesehatan Masyarakat Universitas Hasanuddin Makassar.
- Freedman DS, Zuguo M, Srinivasan SR, Berenson GS, Dietz WH(2007). Cardiovascular risk factors and excess adiposity among overweight children and adolescents: the Bogalusa Heart Study. *J Pediatr*. 150(1):12–17.
- Hill A, Buckley J, Murphy K, Howe P (2006). Combining fish oil supplementation with regular aerobic exercise improves body composition and cardiovascular risk factors. *Am. J. Clin. Nutr.* 85: 1267-1274.
- IDAI (2014a). *Konsensus Ikatan Dokter Anak Indonesia: Diagnosis dan Tata laksana Sindrom Metabolik pada Anak dan Remaja*. www.idai.or.id diakses pada 20 Mei 2016.
- _____. (2014b). *Rekomendasi Ikatan Dokter Anak Indonesia; Diagnosis, Tata Laksana dan Pencegahan Obesitas pada Anak dan Remaja*. www.idai.or.id diakses pada 20 Mei 2016.
- Lee G, Kim HR (2013). Mothers' Working Hours and Children's Obesity: Data from the Korean National Health and Nutrition Examination Survey, 2008–

2010. *Annals of Occupation and Environment Med.* 25:28.
- Musaiger AO (2004). Overweight and Obesity in the Eastern Mediterranean Region: Can We Control It?. *Eastern Mediterranean Health Jour.* 8(8B): 2501-2511.
- OctariC, Liputo NIL, Edison (2014). Hubungan Status Sosial Ekonomi dan Gaya Hidup dengan Kejadian Obesitas pada Siswa SD Negeri 08 Alang Lawas Padang. *Jurnal Kesehatan Andalas.* 3: 131-135.
- OECD(2014). Obesity Update June 2014. www.oecd.org diakses 15 Mei 2016.
- Reaven GM(1997). Do high carbohydrate diets prevent the development or attenuate the manifestations (or both) of syndrome X? A viewpoint strongly against. *Current opinion in lipidology.* 8(1): 23-7.
- Sartika RAD (2011). Faktor Risiko Obesitas Pada Anak 5-15 Tahun Di Indonesia. *Makara.* 15(1): 37-43.
- Simatupang MR (2008). Pengaruh pola konsumsi, aktivitas fisik dan keturunan terhadap kejadian obesitas pada siswa SD Swasta di Kecamatan Medan Baru Kota Medan. Tesis. Universitas Sumatera Utara Medan.
- Swinburn BA, Caterson I, Seidell JC, James WPT (2004). Diet, nutrition and the prevention of excess weight gain and obesity. *Public Health Nutr.* 7(1A):123-146.
- WHO Europe (2007). The Challenge of Obesity in the WHO European Region and the Strategies for Response; Summary. www.euro.who.int diakses pada 15 Mei 2016.
- WHO (2003). Global Strategy on Diet, Physical Activity and Health. www.who.int diakses pada 19 Mei 2016.
- _____ (2015a). From MDGs to SDGs a New Era for Global Public Health 2016-2030; Women & Health are Central to Sustainable Development. www.who.int diakses pada 18 Mei 2016.
- _____ (2015b). World Health Statistics 2015. www.who.int diakses pada 18 Mei 2016.