



Gaya Hambat Saat Hidro Planing dan Gaya Angkat Aerodinamika Saat Cruise di Efek Permukaan pada Pesawat Wing in Surface Effect

The Hump Drags During Hydro Planing and Aerodynamic Lift During Cruise in Surface Effect Altitude Of Wing in Surface Effect Craft

Sayuti Syamsuar

Pusat Teknologi Industri dan Sistem Transportasi, Badan Pengkajian dan Penerapan Teknologi (BPPT)
email: sayuti.syamsuar@bppt.go.id dan sayutisyamsuar@yahoo.com

INFO ARTIKEL

Histori Artikel:

Diterima: 28 Maret 2016

Direvisi: 30 Mei 2016

Disetujui: 29 Juni 2016

Keywords:

Performance, fluid dynamics, towing tank, hump drag, hydro planing, cruise.

Kata kunci:

Remote Control (RC) model Flying Boat, simulasi, hydro

ABSTRACT / ABSTRAK

The computational fluid dynamics of 3 Dimensions model of Wing in Surface Effect craft is very important to proof the model towing test and flight testing data. The inverse delta wing and shoulder airfoil is by using Clark Y of Lippisch configurations have been designed for the surface effect characteristics. The first Maxsurf software are used to compared the towing test results during hydro planing phase. The second ANSYS CFX software is used to calculate the hump drags and aerodynamic lift of Wing In Surface Effect craft 8 seaters 3 Dimensions model to verified the Design Requirement and Objectives.

The forces equilibrium on the body axis during hydro planing are very important to fulfill the take off phase on the water surface. And, the aerodynamic lift for Maximum Take off Weight of 8 seaters configuration is 32,000.0 Newton during cruise speed at 80.0 knots on the 2.5 meter altitude.

The experimental aspects of towing tank test model and Wing In Surface Effect craft (1-2) seaters prototype during hydro planing test have been proposed by using the hydrodynamic wave and porpoising effect theory.

Perhitungan komputasional dinamika fluida pada model 3 Dimensi pada pesawat Wung In Surface Effect sangat penting untuk mengetahui data hasil uji towing tank dan uji terbang. Konfigurasi Lippisch mempunyai sayap berbentuk inverse delta dan punuk di atasnya menggunakan airfoil jenis Clark Y yang telah dirancang untuk memenuhi karakteristik efek permukaan. Piranti lunak pertama Maxsurf digunakan untuk membandingkan hasil uji model towing tank saat fase hydro planing. Piranti lunak kedua ANSYS CFX digunakan untuk menghitung gaya hambat air dan gaya angkat aerodinamika dari pesawat Wing In Surface Effect kapasitas 8 orang model 3 Dimensi dengan konfigurasi Berat Maksimum saat take off sebesar 32,000 Newton pada kecepatan cruise 80.0 knots pada ketinggian terbang 2.5 meter.

Aspek eksperimen pada uji model towing tank dan data uji terbang pada prototipe pesawat Wing In Surface Effect kapasitas (1-2) orang saat hydro planing dijelaskan dengan menggunakan teori gelombang hidrodinamika dan porpoising efek.

INTRODUCTION

The Wing In Surface effect vehicle can be defined as a vehicle with an engine which is designed to operate in proximity to an underlying surface for efficient utilization of the Surface effect. We find from experiment that the 180.0 HP of power engine could not cover the 10,000 [Newton] weight of Wing In Surface Effect (=WISE) craft (1-2) seaters A2B prototype. The WISE-craft (1-2) seaters A2B prototype has been tested at Pantai Carita, Bojonegara, Banten Province. Some problem were found on the field performance during hydro planing such as control surface effectiveness, wing loading, tail heavy, pontoon and water spray. The aerodynamic and hydrodynamic lift with the power could not counter the weight and water resistances during high speed hydro planing. The hump drag on the model towing tank test has been measured on the Indonesia Hydrodynamic Laboratory, Surabaya. The static thrust engine to know the Thrust per Weight ratio is measured from the prototype thrust measurement. The weight and balance has been measured in the laboratory also.

THEORY

Surface effect is a phenomenon of increase of an aerodynamic lift force and reduction of inductive resistance of a wing approaching a surface. The extent of this phenomenon depends on the design of the craft but generally occurs at an altitude less than the mean chord length of the wing.

The WISE craft are categorized according to the following types:

- Type A; a craft which is certified for operation only in surface effect
- Type B; a craft which is certified to temporarily increase its altitude to a limited height outside the influence of surface effect but not exceeding 150.0 meter above the surface; and
- Type C; a craft which is certified for operation outside of surface effect and exceeding 150.0 meter above the surface

Rarely can one find a body of water open to the atmosphere that does not have waves on its surface. These waves are a manifestation of forces acting on the fluid tending to deform it

against the action of gravity and surface tension, which together act to maintain a level fluid surface. Thus it requires a force of some kind, such as would be caused by a gust of wind or a falling stone impacting on the water, to create waves.

The importance of waves cannot be overestimated. Anything that is near or in a body of water is subject to wave action. At the coast, this can result in the movement of sand along the shore, causing erosion or damage to

structures during storms. In the water, offshore oil platforms must be able to withstand severe storms without destruction.

At the present time WISE-craft is poised between success and failure. Wing In Surface Effect craft is not experiencing a high level of activities in the 1960-80's, but there is still a low level of activities underway worldwide which proceeds with mixed successes.

Further, any ship moving through water creates a pressure field and, hence, waves. These waves create a significant portion of the resistance to motion encountered by the WISE-craft.

Forces distribution

As illustration, it can be seen in Figure 1 the forces distribution acting on the centre of gravity, c.g position and centre of buoyancy, c.b during planing on the WISE-craft.

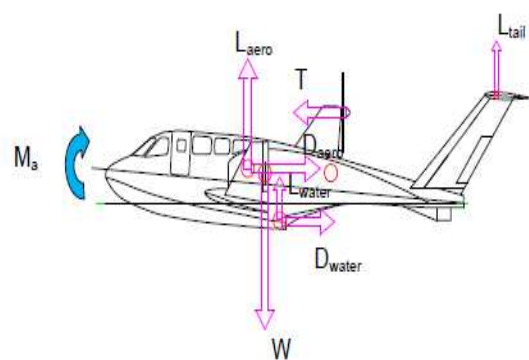

Figure 1 The forces and moments distribution acting on the body of WISE-craft during hydro planing.

The porpoising effect

Stability problems of WISE-craft A2B B type prototype is very important even in calm water.

For planing mono hulls with pontoons on WISE-craft running with high speed that is well known of dangerous motions can occur caused by transverse or longitudinal stability. Porpoising is unstable coupled heave and pitch motions. Transverse instability can result in a

sudden large heel; in loss of course keeping ability due the dynamically induced transverse plane asymmetry.

The Figure 2 is a curve of the resistance acting on the hull in between porpoising and non porpoising conditions.

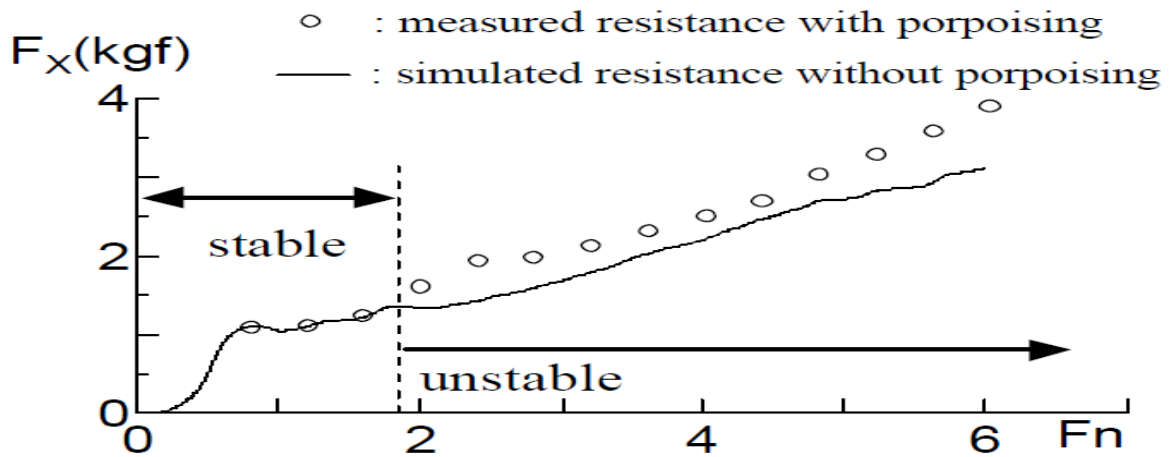

Figure 2 Resistances in porpoising effect

Longitudinal instability can cause self induced heave and pitch oscillations (porpoising effect) and submergence of the bow area (bow drop). Energy of porpoising motion must be generated from the energy of other mode of motion.

If we adopt a coordinate system normal to a coastline, and the wind blows at an angle, θ to the coast normal (Figure 4), then the onshore wind shear stress is $\tau_{wx} = |\tau_w| \cos \theta$. The linear equation of motion in this direction is

$$\frac{\partial U}{\partial t} = -g \frac{\partial \eta}{\partial x} + \frac{1}{\rho(h+\eta)} [\tau_{wx}(\eta) - \tau_{wx}(-h)] \dots \dots \dots (1)$$

Conservation of mass

In a real fluid, mass must be conserved; it can not be created or destroyed. To develop a mathematical equation to express this concept, consider a very small cube located with its center at x, y, z in a Cartesian coordinate system as shown in Figure 3.

For a long time, the flow U in the x direction must be zero, due to the presence of the coast, and therefore the steady state equations show that the wind shear stress is balanced by the bottom shear stress as well as a hydrostatic pressure gradient.

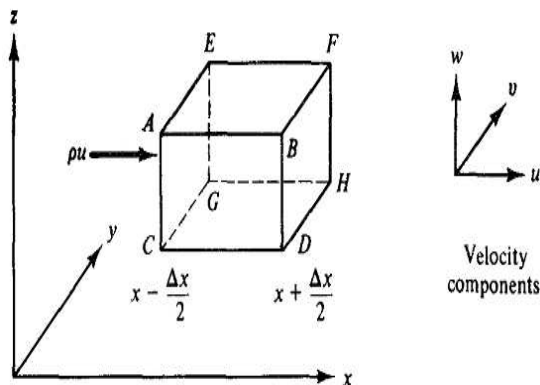

Figure 3 Reference cube in a fluid9).

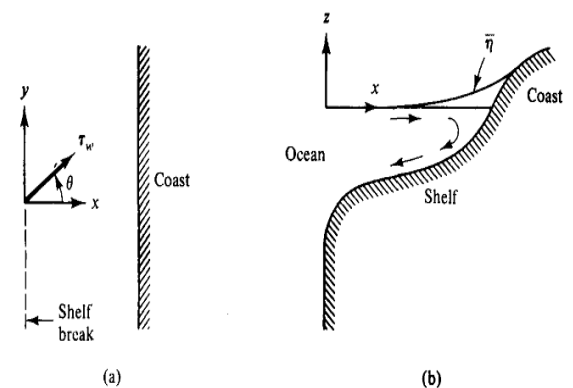

Figure 4 (a) Plan (b) cross sectional view of the coast9).

LITERATURE REVIEW

The aerodynamic and hydrodynamic forces and moments as theoretical calculation, wind tunnel model test results and towing test model of WISE-craft have been used as data collection for prototype flight testing in the ocean near by Pantai Carita, Bojonegara, Banten.

The hydrodynamic forces software calculation by Maxsurf and towing test model on 8 seaters configuration

A first software analysis is calculated by Maxsurf to determine the hump drag of WISE-craft 8 seaters Lippisch configuration B type prototype.

The hump drag, in kN versus Froude Number, Fr curve is presented as theoretical (blue) and towing tank experiment (red) as showed in Figure 5.

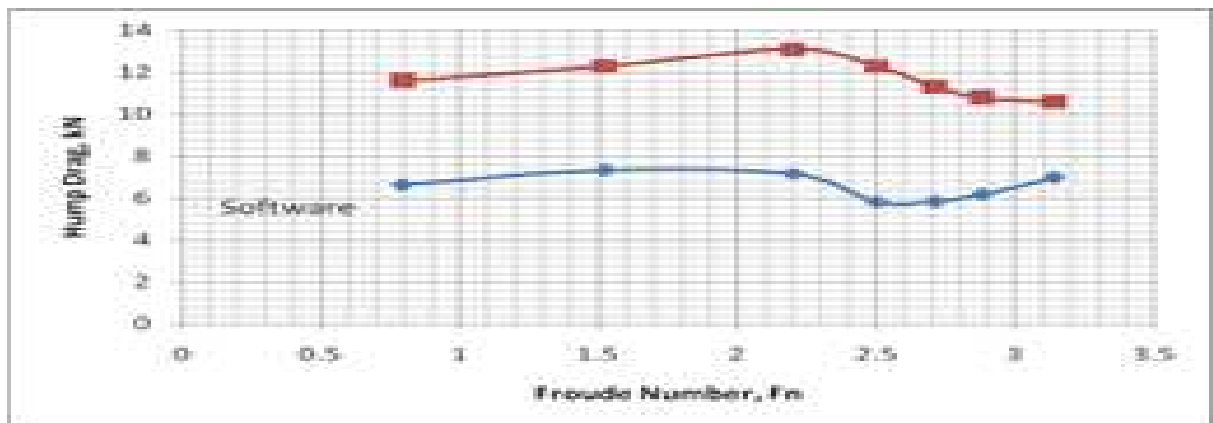

Figure 5 Hump drags versus Fr curve (Maxsurf and towing test result).

The 3 Dimensions (3 D) of WISE-craft 8 seaters configuration model as input data on Maxsurf

software as shown in Figure 6. The Figure 7 is the towing tank model construction.

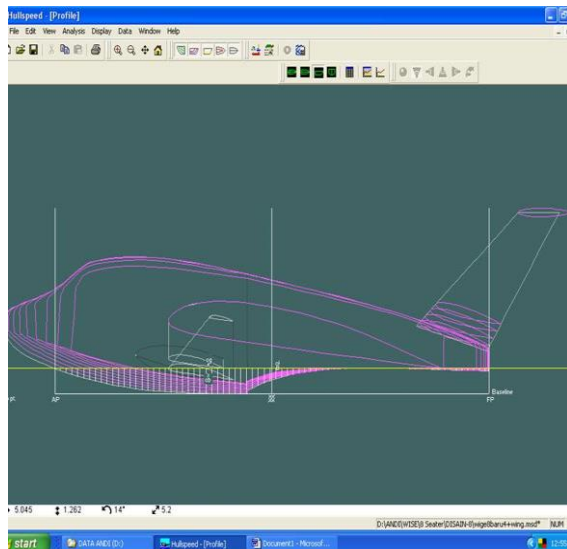

Figure 6 The 3 D model of WISE-craft 8 seaters Lippisch configuration.

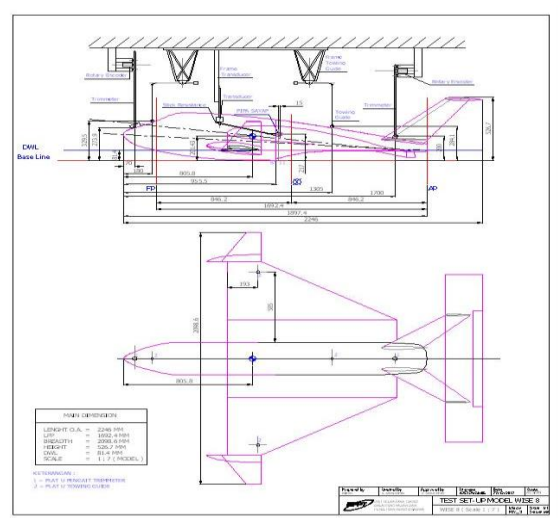

Figure 7 The towing tank WISE craft model constructions.

The Figure 8 is the towing tank test model of WISE craft 8 seaters configuration during tested in Indonesia Hydrodynamic Laboratory (IHL), Surabaya.



Figure 8 Towing tank test model in the IHL, Surabaya.

The WISE-craft A2B (1-2) seaters B type prototype during flight testing

The hydro planing phase of WISE-craft (1-2) seaters prototype flight testing at different airspeeds as shown in Figure 9. The A2B prototype has been tested at the Pantai Carita, Bojonegara on Banten Province in 21-22 April 2009.



Figure 9 The WISE-craft 2 seaters A2B prototype flight tested on the sea.

RESULTS AND DISCUSSION

The ANSYS CFX software to determine hump drag during hydro planing phase

A second software analysis is calculated by ANSYS CFX to determine the hump drag (=hydrodynamic drag) of WISE-craft 8 seaters Lippisch configuration 3 D model are presented in Figure 10 and Figure 11. The hydrodynamic lift and drags, in kN versus Froude Number, Fr curve is presented in Figure 12.

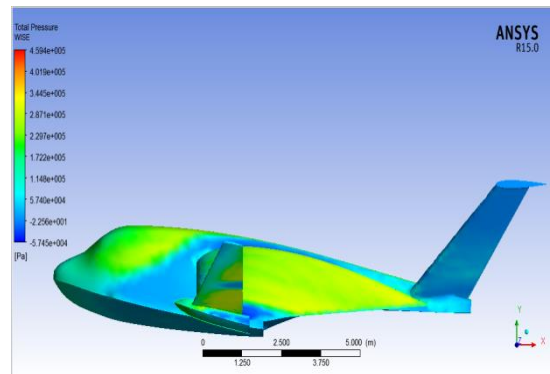

Figure 10 The water line = 40 cm and airspeed = 50.0 knots (left side) of WISE craft.

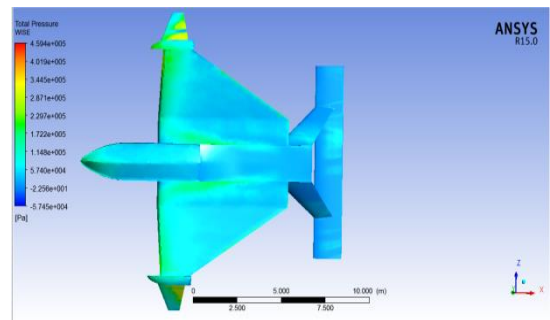

Figure 11 The water line = 40 cm and airspeed = 50.0 knots (bottom side) of WISE craft.

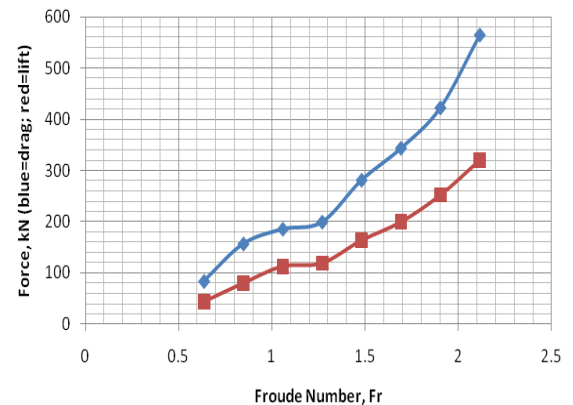

Figure 12 The hydrodynamic lift and drags curve of WISE-craft 8 seater's Lippisch configuration 3 D model.

The CFX ANSYS software to determine the surface effect during cruise phase

The pressure distributions of WISE-craft 8 seaters Lippisch configuration 3 D model during cruise on the 2.5 m height and airspeed 80 knots is showed in Figure 13.

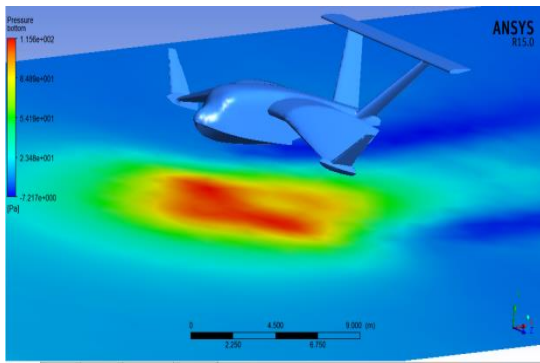

Figure 13 Pressure distributions at h= 2.5 m and airspeed = 80.0 knots of WISE craft 8 seaters Lippisch configuration

The aerodynamic lift of WISE-craft 8 seater's 3 D model on 2.5 meter height is bigger than aerodynamic lift on 3.0 meter height. This theoretical analysis is fulfill to the Design Requirement and Objective for Wing In Surface Effect craft 8 seaters Lippisch configuration. The aerodynamic lift results are showed in Table 1.

Table 1 The dimension of WISE-craft 8 seaters configuration.

Dimension	Value	Unit
Length	16665	Meter
Width	15.155	Meter
High	3.797	Meter
Ground Alt.	2.5; 3.0	Meter
Airspeeds	80.0	Knots
Lift; 2.5 m	33523.7	Newton
Lift; 3.0 m	32984.4	Newton

The fabrication of WISE-craft 8 seaters Lippisch configuration B type prototype is showed in Figure 14.



Figure 14 The WISE craft 8 seaters Lippisch configuration prototype B type.

CONCLUSIONS

The conclusions of hump drag results, WISE-craft A2B (1 - 2) seaters Lippisch configuration B type prototype flight testing and the WISE-craft 8 seaters of Lippisch configuration B type 3 D model are:

- o The total moment acting on the WISE-craft prototype were the sum of the aerodynamic and hydrodynamic moments contribution about the centre of gravity, (c.g) of body and centre of buoyancy, (c.b) of the hull.
- o There are needed the power more than 180 HP (≈ 2255.5 Newton, static Thrust) to anticipate the hump drag and porpoising effect to produces lift off speed during hydro planing. The static Thrust per Weight ratio is around 0.4.
- o The hump drag curve of ANSYS CFX calculation on Wing In Surface Effect craft 8 seaters Lippisch configuration 3 D model is bigger then Maxsurf and towing test model results.
- o The hydrodynamic lift and drags affecting on the trim during hydro planing of WISE craft 8 seaters Lippisch configuration 3 D model have been calculated by ANSYS CFX. The hydrodynamic lift and drags versus Froude number, Fr between 0.6 to 2.1 have a good result.
- o The aerodynamic lift results during cruise phase of WISE craft 8 seaters Lippisch configuration 3 D model on the ground effect altitude is fulfill to the Design Requirement and Objective.

REFERENCES

- Ikeda Yoshiho, Katayama Toru, *Porpoising Oscillations of a Very High Speed Marine craft*, Department of Marine System Engineering, Osaka Prefecture University, 2000
- M Collu, M H Patel, F Trarieux, A Mathematical model to analyze the static stability of hybrid (Aero-Hydrodynamically supported) vehicles, presented at the 8 th. Symposium on high speed marine vehicle, Naples, 21-23 May 2008.
- Maurizio Collu, Minno H Patel, Florent Trarieux, A Unified Mathematical Model for High Speed Hybrid (Air and Water borne) Vehicles, Cranfield University, United Kingdom, 2007

- Odd M. Faltinsen, Hydrodynamics of High Speed Marine Vehicles, Norwegian University of Science and Technology, Cambridge University Press, 2005.
- Chapter 2 Wing In Ground Effect Vehicles, NATO PFP Unclassified, R & T Organization, RTO-TR-AVT-081-02.
- Chapter 3, Wing In Ground Effect Vehicles, NATO PFP Unclassified, R & T Organization, RTO-TR-AVT-081-05.
- Tomasz Abramowski, Numerical Investigation of airfoil in ground proximity, Journal of Theoretical and Applied Mechanics, pp 425-436, Technical University of Szczecin, Warsaw 2007
- Tristan Perez, Prof. Thor I Fossen, NTNU, Manoeuvring Models (Module 4), New Castle, Australia, 2007.
- Robert G. Dean, Robert A, Dalrymple, Water wave Mechanics for Engineers and Scientist, Volume 2 ced Series on Ocean Engineering, Cornell University, World Scientific Publishing Co., USA, 2000
- Tim WISE LPPM-ITB, Laporan Akhir Desain Konfigurasi, Preliminary Design PART I-A: WISE 8 Design Requirements and Objectives, BPPT-ITB, Bandung, 07 Desember 2005

