



Open-independent, open-locating-dominating sets

Suk J. Seo^a, Peter J. Slater^b

^aComputer Science Department,
Middle Tennessee State University,
Murfreesboro, TN 37132, U.S.A.

^bMathematical Sciences Department and Computer Science Department,
University of Alabama in Huntsville
Huntsville, AL 35899, U.S.A.

sseo@mtsu.edu, slater@uah.edu and pslater@cs.uah.edu

Abstract

A *distinguishing set* for a graph $G = (V, E)$ is a dominating set D , each vertex $v \in D$ being the location of some form of a locating device, from which one can detect and precisely identify any given “intruder” vertex in $V(G)$. As with many applications of dominating sets, the set D might be required to have a certain property for $\langle D \rangle$, the subgraph induced by D (such as independence, paired, or connected). Recently the study of independent locating-dominating sets and independent identifying codes was initiated. Here we introduce the property of open-independence for open-locating-dominating sets.

Keywords: distinguishing sets, open-independent sets, open-locating-dominating sets, open-independent, open-locating-dominating sets

AMS subject classification: 05C69

DOI:10.5614/ejgta.2017.5.2.2

1. Introduction

For a graph $G = (V, E)$ that represents a facility, an “intruder” in the system might be a thief, saboteur or fire. If G represents a multiprocessor network with each vertex representing one processor, an “intruder” might be a malfunctioning processor. We assume that certain vertices will

Received: 15 December 2015, Revised 4 April 2017, Accepted: 19 May 2017.

be the locations of detectors, each detector having some capability to identify the location of an intruder vertex.

For $u, v \in D$, let $d(u, v)$ denote the distance in G between u and v . Some detectors, like sonar devices, can be assumed to determine the distance to the intruder vertex x anywhere in the system. Much work has been done on *locating sets* as introduced in Slater [36] (and also called *metric bases* as independently introduced in Harary and Melter [11]). An (ordered) set $X = \{x_1, x_2, \dots, x_k\} \subseteq V(G)$ is a *locating set* if for every $w \in V(G)$ the ordered k -tuple $(d(x_1, w), d(x_2, w), \dots, d(x_k, w))$ uniquely determines w . We say that a vertex x *resolves* vertices u and v if $d(x, u) \neq d(x, v)$. Then X is *locating* if for every two vertices u and v at least one $x_i \in X$ resolves u and v . For the recently introduced centroidal bases described in Foucaud, Klasing and Slater [9] the set of detectors in X provide just an ordering of the relative distances to an intruder vertex, not the exact distances.

Some detectors (heat sensors, motion detectors, etc.) have a limited range. The *open neighborhood* of vertex v is $N(v) = \{w \in V(G) : vw \in E(G)\} = \{w \in V(G) : d(v, w) = 1\}$, and the *closed neighborhood* $N[v] = N(v) \cup \{v\} = \{w \in V(G) : d(v, w) \in \{0, 1\}\}$. Vertex set $D \subseteq V(G)$ is *dominating* if $\cup_{x \in D} N[x] = V(G)$. For $S \subseteq V(G)$ the distance $d(w, S) = \min\{d(x, w) : x \in S\}$, so D is *dominating* if for every $w \in V(G)$ we have $d(w, D) \in \{0, 1\}$. Vertex set D is an *open dominating set* (also called a *total dominating set*) if $\cup_{x \in D} N(x) = V(G)$, that is for every vertex w (including $w \in D$) there is a vertex $x \in D$ with $d(w, x) = 1$.

For the case in which a detector at v can determine if the intruder is at v or if the intruder is in $N(v)$ (but which element in $N(v)$ can not be determined), as introduced in Slater [37, 38, 39], a *locating-dominating set* $L \subseteq V(G)$ is a dominating set for which, given any two vertices u and v in $V(G) - L$, one has $N(u) \cap L \neq N(v) \cap L$, that is, for any two distinct vertices u and v (including ones in L) there is a vertex $x \in L$ with $d(x, u) \in \{0, 1\}$ and $d(x, u) \neq d(x, v)$ or $d(x, v) \in \{0, 1\}$ and $d(x, u) \neq d(x, v)$. Every graph G has a locating-dominating set, namely $V(G)$, and the *locating-dominating number* $LD(G)$ is the minimum cardinality of such a set. See, for example, [3, 8, 17].

As introduced by Karpovsky, Charkrabarty and Levitin [22], an *identifying code* $C \subseteq V(G)$ is a dominating set for which given any two vertices u and v in $V(G)$ one has $N[u] \cap C \neq N[v] \cap C$, that is, there is a vertex $x \in C$ with $d(x, u) \leq 1$ and $d(x, v) \geq 2$ or $d(x, v) \leq 1$ and $d(x, u) \geq 2$. See, for example, [2, 4, 25]. Graph G has an identifying code when for every pair of vertices u and v we have $N[u] \neq N[v]$, and the *identifying code number* $IC(G)$ is the minimum cardinality of such a set.

When a detection device at vertex v can determine if an intruder is in $N(v)$ but will not/can not report if the intruder is at v itself, then we are interested in open-locating-dominating sets as introduced for the k -cubes Q_k by Honkala, Laihonen and Ranto [21] and for all graphs by Seo and Slater [26, 27]. An open dominating set $S \subseteq V(G)$ is an *open-locating-dominating set* if for all u and v in $V(G)$ one has $N(u) \cap S \neq N(v) \cap S$, that is, there is a vertex $x \in S$ with $d(x, u) = 1 \neq d(x, v)$ or $d(x, v) = 1 \neq d(x, u)$. A graph G has an open-locating-dominating set when no two vertices have the same open neighborhood, and $OLD(G)$ is the minimum cardinality of such a set. See, for example, [5, 16, 21, 28, 29, 30, 31, 32, 33]. Lobstein [24] maintains a bibliography, currently with more than 300 entries, for work on these topics.

Dominating sets D have many applications (see Haynes, Hedetniemi and Slater [12, 13]), and in many cases the subgraph generated by D , denoted $\langle D \rangle$, is required to have an additional property

such as independence, paired, or connected. Recently, independent locating-dominating sets and independent identifying codes have been introduced in Slater [42]. Not all graphs have independent locating-dominating sets (respectively, independent identifying codes), and there is no forbidden subgraph characterization of such graphs. In fact, we have the following.

Theorem A (Slater [42]) *Simply deciding, for a given input graph G , if G has an independent locating-dominating set is NP-complete.*

Theorem B (Slater [42]) *Simply deciding, for a given input graph G , if G has an independent identifying code is NP-complete.*

Note that, by definition, an open dominating set S can not be independent, each $v \in S$ must be open dominated by some $x \in N(v)$. In this paper we consider “open-independence” and introduce open-independent, open-locating-dominating sets.

2. Open-independent sets; open-independent-dominating sets; open-independent, open dominating sets

Assuming every vertex is the possible location of an intruder and that a detector at vertex v can not detect an intruder at $w \in V(G)$ if $d(v, w) \geq 2$, in order for every intruder to be detectable we require a dominating set for the detectors. Vertex set $D \subseteq V(G)$ is *dominating* if every vertex w not in D is adjacent to a vertex $v \in D$, equivalently, (a) $\cup_{x \in D} N[x] = V(G)$ or (b) $V(G) - D$ is enclaveless (Note that a set $E \subseteq V(G)$ is defined to be *enclaveless* if every vertex in E is adjacent to at least one vertex $V(G) - E$). Also, $S \subseteq V(G)$ is *independent* if no two vertices in S are adjacent. Now, $R \subseteq V(G)$ is dominating when condition (1) below holds, and R is independent when (2) below holds.

(1) for every $v \in V(G)$, $|N[v] \cap R| \geq 1$.

(2) for every $v \in R$, $|N[v] \cap R| \leq 1$.

Obviously every $v \in R$ satisfies $|N[v] \cap R| \geq 1$, so condition (2) could be replaced with $v \in R$ implies $|N[v] \cap R| = 1$. We use \leq for what follows in (4).

For open domination, one assumes that a vertex v does not dominate itself. An intruder (thief, saboteur, fire) at v might prevent its own detection; a malfunctioning processor might not detect its own miscalculations. Vertex set $R \subseteq V(G)$ is open-dominating if $\cup_{v \in R} N(v) = V(G)$ or, equivalently, if condition (3) holds.

(3) for every $v \in V(G)$, $|N(v) \cap R| \geq 1$.

Now we define $R \subseteq V(G)$ to be *open-independent* if (4) holds. That is, R is independent if each vertex $v \in R$ is dominated by R at most (equivalently, exactly) once, and R is open-independent if each vertex $v \in R$ is open-dominated by R at most once.

The *open-independence number* for a graph G denoted by $OIND(G)$ is the maximum cardinality of an open-independent set for G . Note that $OIND(G) \geq \beta(G)$, where $\beta(G)$ denotes the maximum cardinality of an independent set for G .

(4) for every $v \in R$, $|N(v) \cap R| \leq 1$.

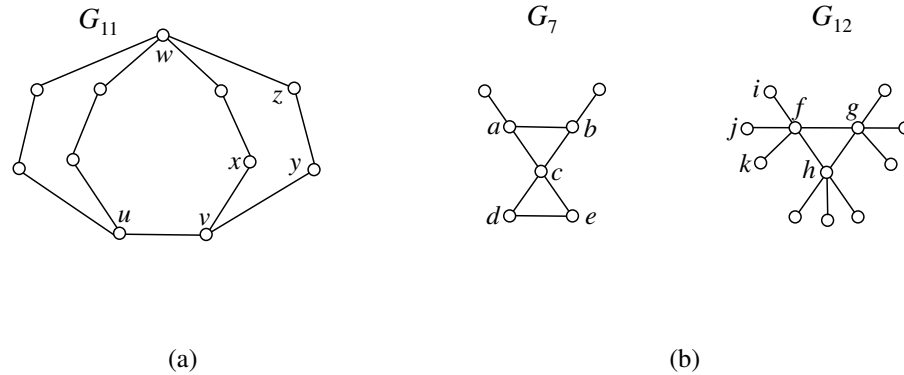

Figure 1. Graphs G_{11} , G_7 , and G_{12} .

The *domination number* $\gamma(G)$ is the minimum cardinality of a dominating set, a dominating set of cardinality $\gamma(G)$ being called a $\gamma(G)$ -set whereas any dominating set is called a γ -set. Similar terminology is used for other parameters. The *independent domination number* (which could be denoted $\gamma_{IND}(G)$) is traditionally denoted by $i(G)$ and is the minimum cardinality of a dominating set D for which every component of $\langle D \rangle$ is a singleton. We let $\gamma_{OIND}(G)$ denote the minimum cardinality of an *open-independent dominating set* D , a dominating set D for which each component of $\langle D \rangle$ has cardinality at most two, $\langle D \rangle = jK_1 \cup kK_2$. Clearly $\gamma(G) \leq \gamma_{OIND}(G) \leq i(G)$.

The *open (or total) domination number*, the minimum cardinality of an open dominating set is denoted γ_t or γ^{OP} . We let γ_{OIND}^{OP} denote the *open-independent, open domination number*, the minimum cardinality of an open dominating set D for which every component of $\langle D \rangle$ is a K_2 , when such a set exists. If so, then $\gamma^{OP}(G) \leq \gamma_{OIND}^{OP}(G)$. Note, for example, that the 5-cycle C_5 does not have an open-independent, open dominating set.

For the graph G_{11} in Figure 1(a) the set $\{u, v, w\}$ is the minimum dominating set which is open-independent and $\gamma(G_{11}) = \gamma_{OIND}(G_{11}) = 3$; $i(G) = 4 = |\{u, w, x, y\}|$; and $\gamma^{OP}(G_{11}) = 4 = |\{u, v, w, z\}| = \gamma_{OIND}^{OP}(G_{11})$. In Figure 1(b) the graph G_{12} has the minimum dominating set $\{f, g, h\}$ and a minimum open independent dominating set $\{g, h, i, j, k\}$, so $\gamma(G_{12}) = 3 < 5 = \gamma_{OIND}(G_{12})$, and the graph G_7 has the minimum open dominating set $\{a, b, c\}$ and the minimum open independent, open dominating set $\{a, b, d, e\}$, with $\gamma^{op}(G_7) = 3 < 4 = \gamma_{OIND}^{OP}(G_7)$.

Open-independent, open dominating sets have been considered in another context by Studer, Haynes, and Lawson [43]. As introduced in Haynes and Slater [14, 15], a *paired dominating set* D is a dominating set for which $\langle D \rangle$ has a perfect matching. Studer, et al. [43] define an open-independent, open dominating set as an induced-paired dominating set.

As noted, in this paper we are interested in distinguishing sets and will consider open-independent, open-locating-dominating sets.

3. Open-independent, open-locating-dominating sets

For an open-locating-dominating set S each $v \in V(G)$ has a distinct set of detectors, $N(v) \cap S$. A graph G has an open-locating-dominating set (OLD-set) if and only if no two vertices u and v

have the same open neighborhood, that is $N(u) \neq N(v)$. Clearly, $OLD(G) \leq OLD_{OIND}(G)$ in this case. For an open-independent, OLD-set S , the subgraph $\langle S \rangle$ must have each component of order two. We let $OLD_{OIND}(G)$ be the minimum cardinality of an open-independent $OLD(G)$ -set when such a set exists. For the tree T_8 in Figure 2, $OLD(T_8) = 5$ and $OLD_{OIND}(T_8) = 6$.

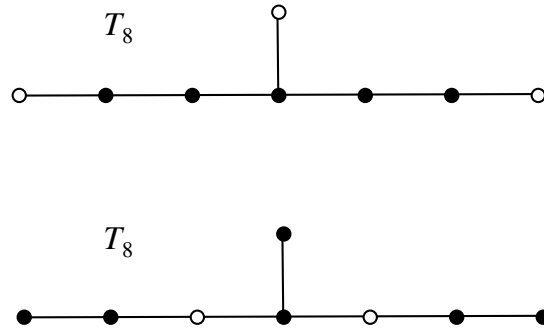

Figure 2. $\gamma^{OP}(T_8) = OLD(T_8) = 5$ and $OLD_{OIND}(T_8) = 6$.

For the tree T_9 in Figure 3, there is an open-independent, open-dominating set of size four, but there does not exist an OLD-set (and, hence, no OLD_{OIND} -set). Note that the 5-cycle does not have an open-independent, open-dominating set (and, hence, no OLD_{OIND} -set).

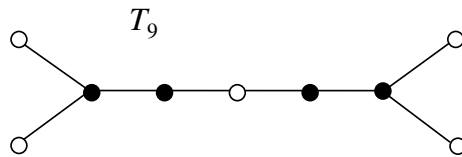

Figure 3. $\gamma_{OIND}^{OP}(T_9) = 4$ and $OLD(T_9)$ is not defined.

Proposition 3.1. *If S is any OLD_{OIND} -set for a graph G and v is an endpoint, $deg_G v = 1$, with $N(v) = \{w\}$, then $\{v, w\} \subseteq S$. In particular, $\{v, w\}$ is contained in any $OLD_{OIND}(G)$ -set.*

Proof. Because $N(v) = w$, any open dominating set S must contain w . Because S is open-independent, $N(w)$ contains exactly one element of S , and because S is open-locating if $N(w) \cap$

$S = \{x\}$ with $x \neq v$ we have the contradiction that $N(v) \cap S = \{w\} = N(x) \cap S$. Hence, $v \in S$. □

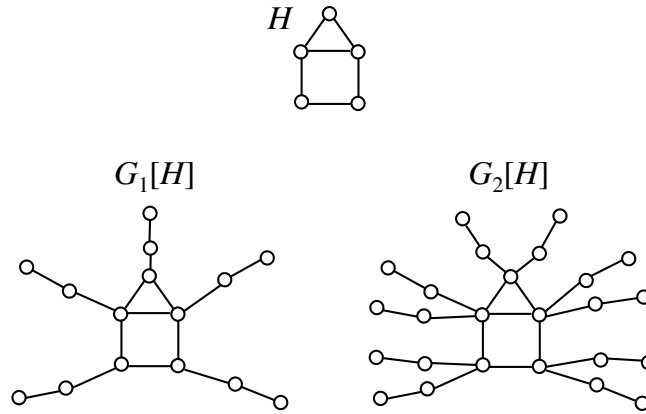

Figure 4. H , $G_1[H]$ and $G_2[H]$.

For any connected graph H of order $n \geq 2$, let $G_1[H]$ be obtained by adding for each $v \in V(H)$ two vertices v' and v'' and edges vv' and $v'v''$, and let $G_2[H]$ be obtained from H by further adding vertices v''' and v'''' and edges vv''' and $v'''v''''$. Then every $G_1[H]$ and $G_2[H]$ have OLD-sets, and $G_2[H]$ has an OLD_{OIND} -set while $G_1[H]$ does not.

Hence, we have the following.

Theorem 3.1. For every graph H there are graphs G_1 and G_2 with H as an induced subgraph where G_1 does not have an OLD_{OIND} -set but G_2 does have an OLD_{OIND} -set.

There is no forbidden subgraph characterization of the set of graphs which have OLD_{OIND} -sets, nor of the set of graphs which do not have OLD_{OIND} -sets. In fact, simply deciding for a given graph G if G has an OLD_{OIND} -set is an NP-complete problem. As noted in Garey and Johnson [10], Problem 3-SAT is NP-complete.

3-SAT

INSTANCE. Sets $U = \{u_1, u_2, \dots, u_n\}$ and $\bar{U} = \{\bar{u}_1, \bar{u}_2, \dots, \bar{u}_n\}$ and collection $C = \{c_1, c_2, \dots, c_m\}$ of 3-element subsets of $U \cup \bar{U}$.

QUESTION. Does there exist a satisfying truth assignments for C , that is, a subset S of $U \cup \bar{U}$ of order n with $|S \cap \{u_i, \bar{u}_i\}| = 1$ for $1 \leq i \leq n$ with $S \cap c_j \neq \emptyset$ for $1 \leq j \leq m$?

XOIOLD (existence of an open-independent, open-locating-dominating set)

INSTANCE. A graph G .

QUESTION. Does G have an OLD_{OIND} -set?

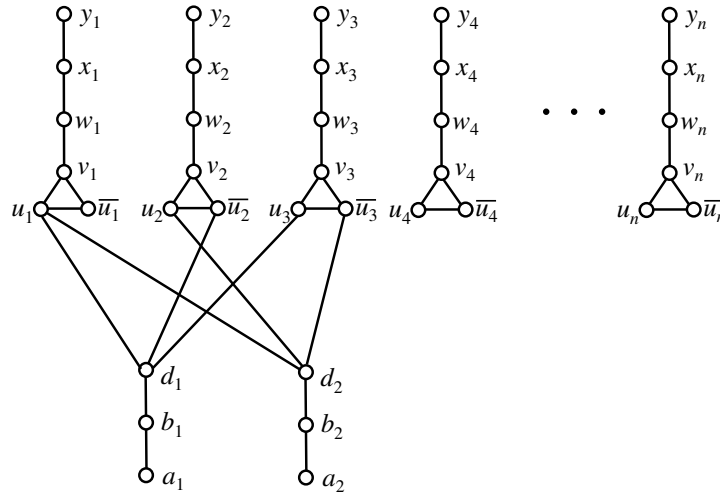

Figure 5. $c_1 = \{u_1, \bar{u}_2, u_3\}$, $c_2 = \{u_1, u_2, \bar{u}_3\}$, etc.

Theorem 3.2. *Simply deciding, for a given graph G , if G has an open-independent, OLD-set is an NP-complete decision problem. That is, XOIOLD is NP-complete.*

Proof. One can easily verify in polynomial time if a given set $S \subseteq V(G)$ is an OLD_{OIND} -set, so $XOIOLD \in NP$.

We can reduce the known NP-complete 3-SAT problem to XOIOLD in polynomial time as follows. For each $u_i \in U$ let G_i be the 6-vertex graph illustrated in Figure 5 with $V(G_i) = \{u_i, \bar{u}_i, v_i, w_i, x_i, y_i\}$ and $E(G_i) = \{u_i\bar{u}_i, u_iv_i, \bar{u}_iv_i, v_iw_i, w_ix_i, x_iy_i\}$. For each clause $c_j \in C$ let H_j be the 3-vertex graph with $V(H_j) = \{a_j, b_j, d_j\}$ and $E(H_j) = \{a_jb_j, b_jd_j\}$. Interconnect the clause components and literal components by adding edges $d_jc_{j,1}, d_jc_{j,2}$ and $d_jc_{j,3}$ for $1 \leq j \leq m$ where $c_j = \{c_{j,1}, c_{j,2}, c_{j,3}\} \in C$, as illustrated in Figure 5. Let G be the resulting graph of order $6n + 3m$.

Assume there is a satisfying truth assignment $S \subseteq U \cup \bar{U}$. Form $W \subseteq V(G)$ by letting $\{y_i, x_i, v_i, a_j, b_j\} \subseteq W$ for $1 \leq i \leq n, 1 \leq j \leq m$. For $1 \leq i \leq n$, add u_i to W if the literal $u_i \in S$, otherwise the literal $\bar{u}_i \in S$ and one adds \bar{u}_i to S . Then $\langle W \rangle$ consists of $4n + 2m$ vertices inducing $2n + m$ independent edges. Note that $N(a_j) = \{b_j\} \subseteq W, b_j \in N(d_j) \cap W$ but $|N(d_j) \cap W| \geq 2$ because S is satisfying. It is easily seen that G has W as an open-independent, OLD-set.

Assume G has an OLD_{OIND} -set W . By Proposition 3.1 we have $\{y_i, x_i\} \subseteq W$ with $w_i \notin W$ for $1 \leq i \leq n$, and $\{a_j, b_j\} \subseteq W$ with $d_j \notin W$ for $1 \leq j \leq m$. Because $N(y_i) \cap W = \{x_i\}$ and $N(w_i) \cap W \neq N(y_i) \cap W$, each $v_i \in W$. Now $v_i \in W$ implies the open-independent, dominating set W has $|N(v_i) \cap W| = 1$, so W contains exactly one of u_i and \bar{u}_i . Let $S = W \cap (U \cup \bar{U})$. Because W is an OLD-set $N(a_j) \cap W = \{b_j\} \subsetneq N(d_j) \cap W$, and we have $N(d_j) \cap (U \cup \bar{U}) \neq \emptyset$. That is, S must be a satisfying truth assignment. \square

Theorem 3.3. *If the girth of G satisfies $g(G) \geq 5$ and $W \subseteq V(G)$, then W is an OLD_{OIND} -set if and only if (1) each $v \in W$ is open-dominated exactly once, and (2) each $v \notin W$ is open-dominated at least twice.*

Proof. Assume W is an OLD_{OIND} -set for G . Because W is open-independent and open-dominating, each $v \in W$ has $|N(v) \cap W| = 1$. If $v \notin W$, then W open-dominates v implies there is a vertex $w \in N(v) \cap W$. As noted $|N(w) \cap W| = 1$, say $N(w) \cap W = \{x\}$. Then $N(x) \cap W = \{w\} \neq N(v) \cap W$ implies that $|N(v) \cap W| \geq 2$.

Assume conditions (1) and (2) hold for $W \subseteq V(G)$. Then W is open-dominating. Assume $v \in W$ has $|N(v) \cap W| = 1$. For $N(v) \cap W = \{w\}$, we have $N(w) \cap W = \{v\}$ and $x \in N(w) - \{v\}$ implies that $x \notin W$, so x is open-dominated at least twice. Thus v is the only vertex with $N(v) \cap W = \{w\}$. Assume $v \notin W$, let $\{x, y\} \subseteq N(v) \cap W$. No other vertex u has $\{x, y\} \subseteq N(u) \cap W$ or else u, x, v, y is a 4-cycle and $g(G) \leq 4$. Thus $N(v) \cap W$ uniquely distinguishes v . \square

Assume W is an OLD_{OIND} -set for path $P_n : v_1, v_2, \dots, v_n$. By Proposition 3.1 we have $\{v_1, v_2\} \subseteq W, v_3 \notin W, \{v_4, v_5\} \subseteq W, v_6 \notin W, \dots, \{v_{n-1}, v_n\} \subseteq W$.

Proposition 3.2. *Path P_n has an OLD_{OIND} -set W if and only if $n \equiv 2 \pmod{3}$ and $OLD_{OIND}(P_{3k+2}) = 2k + 2$.*

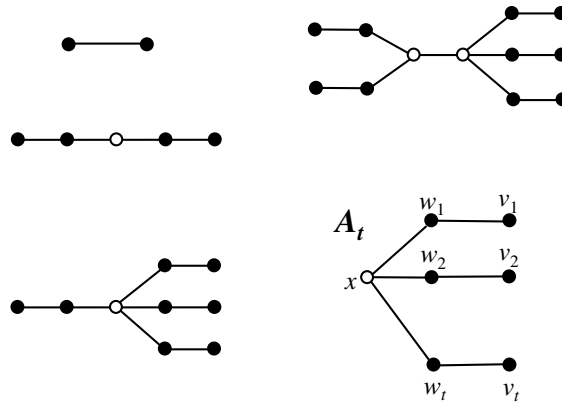

Figure 6. Some trees with OLD_{OIND} -sets.

Theorem 3.4. (Seo and Slater [26]) *A tree T has an OLD -set if and only if no two endpoints of T have the same neighbor.*

Similar to the characterization given in Studer, et al. [43] for open-independent dominating sets in trees, we can recursively define the collection of pairs (T, W) where T is a tree and W is the unique $OLD_{OIND}(T)$ -set. First note that the tree A_t of order $2t + 1$ in Figure 6 has $OLD_{OIND}(A_t) = 2t$ and $V(A_t) - x$ is the unique $OLD_{OIND}(A_t)$ -set for $t \geq 2$.

Theorem 3.5. *If T_n is a tree of order n with an OLD_{OIND} -set, then the $OLD_{OIND}(T)$ -set W is unique and T_n can be obtained recursively from P_2 by a sequence of operations OP1 and OP2 defined as follows.*

(OP1) *Let T^* be a tree with $OLD_{OIND}(T)$ -set W and let $z \in W$. The tree T is obtained from T^* by adding a $P_3 : x, w, v$ and adding the edge zx .*

(OP2) *Let T^* be a tree with $OLD_{OIND}(T)$ -set W and let z be any vertex in T^* . The tree T is obtained from T^* by adding an A_t with $t \geq 2$ and adding the edge zx .*

Proof. We first observe that if T is obtained from T^* by (OP1), then $W \cup \{w, v\}$ is an OLD_{OIND} -set for T , and if T is obtained from T^* by (OP2), then $W \cup \{w_1, v_1, \dots, w_t, v_t\}$ is an OLD_{OIND} -set for T .

Assume tree T has OLD_{OIND} -set W . If T is a path, then Proposition 3.2 shows that T can be obtained from P_2 by a sequence of (OP1)-operations and there is a unique OLD_{OIND} -set for T . If T is not a path, select a vertex y with $deg y \geq 3$ where all or all but one of the branches at y are paths. Suppose y, u_1, u_2, \dots, u_j is a branch path with $j \geq 3$. By Proposition 1 we must have $\{u_{j-1}, u_j\} \subseteq W$ and $u_{j-2} \notin W$. Also u_{j-3} (possibly $u_{j-3} = y$) must be in W or else $N(u_j) \cap W = N(u_{j-2}) \cap W = \{u_{j-1}\}$. Let $T^* = T - \{u_j, u_{j-1}, u_{j-2}\}$. Since W is an OLD_{OIND} -set of T and $N(u_j) \cap V(T^*) = \emptyset$ and $N(u_{j-1}) \cap V(T^*) = \emptyset$, $W - \{u_j, u_{j-1}\}$ is an OLD_{OIND} -set of T^* . So T is obtainable from T^* by (OP1) where $z = u_{j-3}$. Because W is an OLD-set, y can not be the support vertex of two or more endpoints. If y is adjacent to an endpoint x and y, u_1, u_2 is a branch path, Proposition 1 would imply that $\{u_1, u_2\} \subseteq W$ and $\{x, y\} \subseteq W$, so W would not be open-independent. Now y can be assumed to have $deg y - 1 = b$ branch paths of length two. We have a subgraph A_b with vertices $\{y, w_1, v_1, \dots, w_b, v_b\}$ with $b \geq 2$. Let $N(y) = \{w_1, w_2, \dots, w_b, z\}$, and T can be obtained from $T^* = T - \{y, w_1, v_1, \dots, w_b, v_b\}$ by (OP2). \square

4. $OLD_{OIND}\%$ for infinite grids

Much work has been done on distinguishing sets (LD-sets, IC-sets and OLD-sets) in infinite grids (hexagonal, square, triangular, tumbling block, etc). See, for example, [1, 6, 7, 18, 19, 20, 22, 23, 26, 28, 29, 30, 40, 41].

For a given vertex x in a dominating set D in a graph G , the share $sh(x; D)$ is defined in Slater [41] as a measure of how much domination the individual vertex x does. For example, in graph $H1$ of Figure 7 we have $N[3] = \{2, 3, 4, 5, 6, 9\}$ and $sh(3; \{3, 4, 7\}) = 1/2 + 1/2 + 1/2 + 1/3 + 1/2 + 1/3 = 8/3$. Also, $sh(4; \{3, 4, 7\}) = 1 + 1/2 + 1/2 + 1/2 + 1/3 + 1/2 + 1/3 = 11/3$, and $sh(7; \{3, 4, 7\}) = 1/3 + 1/2 + 1 + 1/2 + 1/3 = 8/3$. Note that $\sum_{v \in D} sh(v; D) = |V(G)| = n$ for any dominating set D and that $|D| \geq |V(G)| / MAX_{v \in V} sh(v; D)$.

Similarly, the open share $sh^{op}(x; D)$ is defined in Seo and Slater [26] for open dominating set D . Specifically, if D is open dominating and $x \in D$ then, for each $y \in N(x)$, let

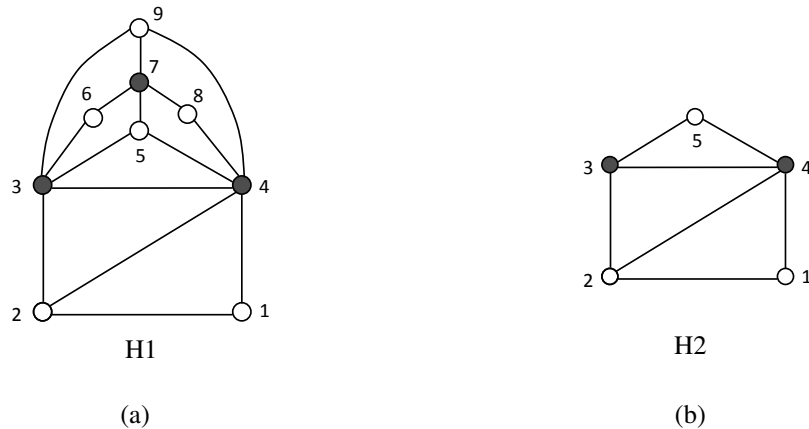

Figure 7. Graphs H_1 and H_2 .

$sh^{op}(x; D(y)) = 1/|N(y) \cap D|$ and let $sh^{op}(x; D) = \sum_{y \in N(x)} sh^{op}(x; D(y))$. For example, in Figure 7 $D = \{3, 4\}$ is an open dominating set for the graph H_2 . We have $N(3) = \{2, 4, 5\}$ and $sh^{op}(3; D) = sh^{op}(3; D(2)) + sh^{op}(3; D(4)) + sh^{op}(3; D(5)) = 1/2 + 1 + 1/2 = 2$. Also, $N(4) = \{1, 2, 3, 5\}$ and $sh^{op}(4; D) = sh^{op}(4; D(1)) + sh^{op}(4; D(2)) + sh^{op}(4; D(3)) + sh^{op}(4; D(5)) = 1 + 1/2 + 1 + 1/2 = 3$. Note that $\sum_{x \in D} sh^{op}(x; D) = |V(G)|$, and if $sh^{op}(w; D) \geq sh^{op}(x; D)$ for all $x \in D$, then $|D| \geq |V(G)|/sh^{op}(w; D)$.

In this paper, we will focus on open-locating-dominating sets along with open-shares of vertices.

Percentage parameters for measuring density for locally-finite, countably infinite graphs were defined in Slater [41]. For example, for the $\gamma(G)$ parameter we have $\gamma\%(G)$ defined as follows as the minimum possible percentage of vertices in a dominating set of G . The closed k -neighborhood of vertex v is the set of vertices at distance at most k from v , $N^k[v] = \{w \in V(G) : d(v, w) \leq k\}$. For $S \subseteq V(G)$, the density of S is $dens(S) = \max_{v \in V(G)} \limsup_{k \rightarrow \infty} (|S \cap N^k[v]|/|N^k[v]|)$. Then, for example, the domination percentage of G is $\gamma\%(G) = \min\{dens(S) : S \subseteq V(G) \text{ is dominating}\}$. Let HEX, SQ, and TRI denote the infinite hexagonal, square and triangular grid graphs, respectively.

Theorem 4.1. (Seo and Slater [26]) $OLD\%(HEX) = 1/2$.

The darkened vertices of HEX in Figure 8 form an $OLD\%(HEX)$ -set D achieving the value $1/2$, and D is an open-independent set. Hence we have the following.

Theorem 4.2. $OLD_{OIND}\%(HEX) = OLD\%(HEX) = 1/2$.

Figure 9(a) illustrates that $OLD\%(SQ) = 2/5$, but $OLD_{OIND}\%(SQ) > OLD\%(SQ)$.

Theorem 4.3. (Seo and Slater [26]) $OLD\%(SQ) = 2/5$.

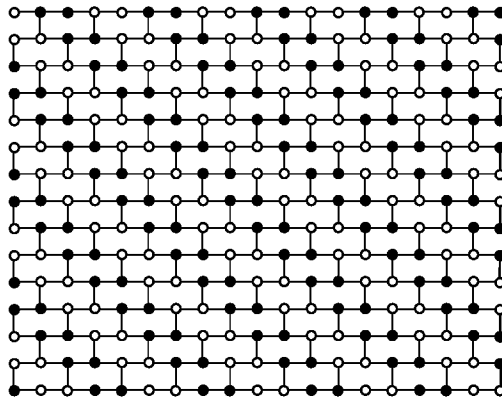
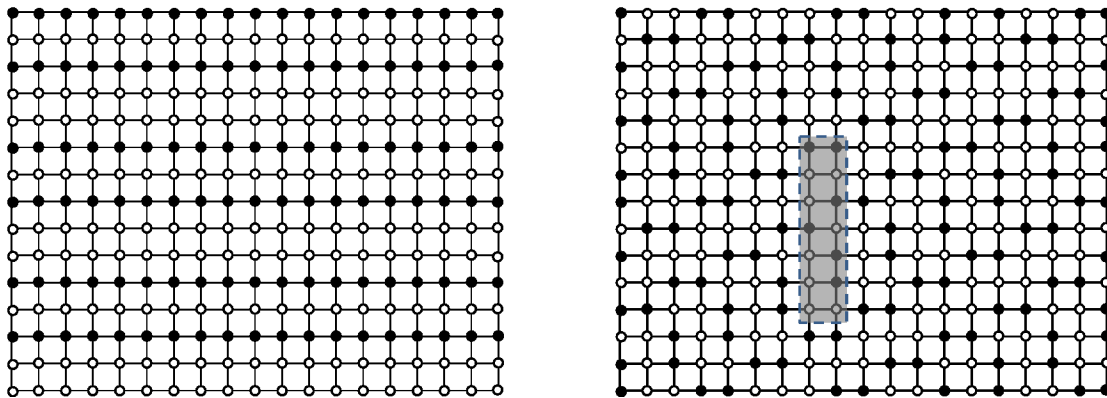

Figure 8. $OLD\%(HEX) = 1/2 = OLD_{OIND}\%(HEX)$.



(a)

(b)

Figure 9. $OLD\%(SQ) = 2/5$ and $OLD_{OIND}\%(SQ) = 3/7$.

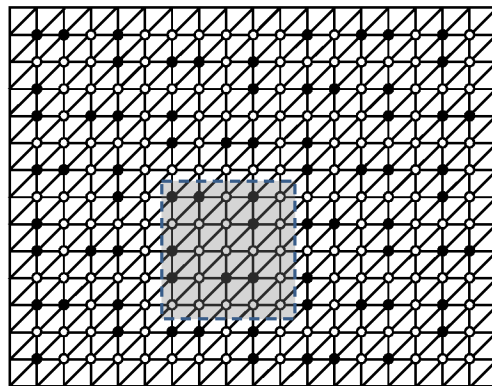

Figure 10. $OLD_{OIND}\%(TRI) \leq 8/25$.

Theorem 4.4. $OLD_{OIND}\%(SQ) = 3/7$.

Proof. The set of darkened vertices in Figure 9(b) shows that $OLD_{OIND}\%(SQ) \leq 3/7$. To see that $OLD_{OIND}\%(SQ) \geq 3/7$ we use a straightforward share argument. Let D be an $OLD_{OIND}\%(SQ)$ -set. We have $V(SQ) = Z \times Z$ and $N((i, j)) = \{(i - 1, j), (i, j + 1), (i + 1, j), (i, j - 1)\}$. We will show that $sh^{op}(x; D) \leq 7/3$ for every $x \in D$, and hence $OLD_{OIND}\%(SQ) \geq 7/3$. Without loss of generality, assume $x = (0, 0) \in D$. Exactly one neighbor of x is also in D , and we can assume that $(1, 0) \in D$. In particular, $sh^{op}(x; D((1, 0))) = 1$. Any other vertex $y \in N(x)$ is open dominated at least twice by D , so $sh^{op}(x, D(y)) \leq 1/2$ for each $y \in \{(-1, 0), (0, 1), (0, -1)\}$. Suppose all three of these vertices give $(0,0)$ a share value of $1/2$.

Case 1. $N((-1, 0)) \cap D = \{(0, 0), (-2, 0)\}$. Then $(-1, 1) \notin D$ with $D \cap \{(-1, 0), (0, 1)\} = \emptyset$, and so $N((-1, 1)) \cap D = \{(-2, 1), (-1, 2)\}$. Similarly, $N((-1, -1)) \cap D = \{(-2, -1), (-1, -2)\}$. But then $\{(-2, 1), (-2, 0), (-2, -1)\} \subseteq D$, contradicting the open independence of D .

Case 2. $N((-1, 0)) \cap D \neq \{(0, 0), (-2, 0)\}$. Then one of $(-1, 1)$ and $(-1, -1)$ is in D , say $(-1, 1)$. Because $sh^{op}((0, 0); D((0, 1))) = 1/2$ we have $N((0, 1)) \cap D = \{(0, 0), (-1, 1)\}$. Also, $sh^{op}((0, 0); D((-1, 0))) = 1/2$ implies $N((-1, 0)) \cap D = \{(0, 0), (-1, 1)\} = N(0, 1) \cap D$, contradicting the fact that D must distinguish $(0,1)$ and $(-1,0)$.

Because $sh^{op}(x; D) < 1 + 1/2 + 1/2 + 1/2$, we have $sh^{op}(x; D) \leq 1 + 1/2 + 1/2 + 1/3 = 7/3$ for every $x \in D$. As noted, this implies $OLD_{OIND}\%(SQ) \geq 7/3$. \square

Theorem 4.5. (Kincaid, Oldham, and Yu [23]) $OLD\%(TRI) = 4/13$.

Figure 10 shows that $OLD_{OIND}\%(TRI) \leq 8/25$. To date, the best we have is that: $OLD_{OIND}\%(TRI) \in [4/13, 8/25]$.

5. Open independent sets

In this paper we focused on open-independence for OLD -sets. Of interest is the parameter $OIND$ itself, as well as the lower open independence parameter $oind$ where $oind(G)$ is the minimum cardinality of a maximally open-independent set.

References

- [1] Y. Ben-Haim and S. Litsyn, Exact Minimum Density of Codes Identifying Vertices in the Square Grid. *SIAM Journal on Discrete Mathematics* **19** (2005), 69–82.
- [2] N. Bertrand, I. Charon, O. Hudry and A. Lobstein, Identifying and locating-dominating codes on chains and cycles, *European Journal of Combinatorics* **25** (2004), 969–987.
- [3] M. Blidia, M. Chellali, R. Lounes and F. Maffray, Characterizations of trees with unique minimum locating-dominating sets, *Journal of Combinatorial Mathematics and Combinatorial Computing* **76** (2011), 225–232.

- [4] M. Blidia, M. Chellali, F. Maffray, J. Moncel and A. Semri, Locating-domination and identifying codes in trees, *Australasian Journal of Combinatorics* **39** (2007), 219–232.
- [5] M. Chellali, N. J. Rad, S. J. Seo and P. J. Slater, On Open Neighborhood Locating-dominating in Graphs, *Electronic Journal of Graph Theory and Applications* **2** (2014), 87–98.
- [6] G.D. Cohen, I. Honkala, A. Lobstein and G. Zémor, Bounds for Codes Identifying Vertices in the Hexagonal Grid, *SIAM Journal on Discrete Mathematics* **13** (2000), 492–504.
- [7] A. Cukierman and G. Yu, New bounds on the minimum density of an identifying code for the infinite hexagonal grid, *Discrete Applied Mathematics* **161** (2013), 2910–2924.
- [8] G. Exoo, V. Junnila and T. Laihonen, Locating-dominating codes in cycles, *Australasian Journal of Combinatorics* **49** (2011), 177–194.
- [9] F. Foucaud, R. Klasing, and P. J. Slater, Centroidal bases in graphs, *Networks* **64** (2014), 96–108.
- [10] M.R. Garey and D. S. Johnson, *Computers and intractability: A guide to the theory of NP-completeness*, W.H. Freeman, (1979).
- [11] F. Harary and R. Melter, On the metric dimension of a graph, *Ars Combinatoria* **2** (1976), 191–195.
- [12] T.W. Haynes, S.T. Hedetniemi, and P.J. Slater, *Fundamentals of Domination in graphs*, Marcel Dekker, Inc., (1998).
- [13] T.W. Haynes, S.T. Hedetniemi, and P.J. Slater, *Domination in Graphs: Advanced Topics*, Marcel Dekker, Inc., (1998).
- [14] T.W. Haynes and P.J. Slater, Paired domination and the paired-domatic number, *Congressus Numerantium* **109** (1995), 67–72.
- [15] T.W. Haynes and P.J. Slater, Paired domination in graphs, *Networks* **32** (1998), 199–206.
- [16] M. Henning and A. Yeo, Distinguishing-transversal in hypergraphs and identifying open codes in cubic graphs, *Graphs and Combinatorics* Published online: 30 March 2013.
- [17] C. Hernando, M. Mora, and I. M. Pelayo, Nordhaus-Gaddum bounds for locating domination, *European Journal of Combinatorics* **36** (2014), 1–6.
- [18] I. Honkala, An optimal locating-dominating set in the infinite triangular grid, *Discrete Mathematics* **306** (2006), 2670–2681.
- [19] I. Honkala, An optimal strongly identifying code in the infinite triangular grid, *Electronic Journal of Combinatorics* **17** (2010), R91.

- [20] I. Honkala and T. Laihonen, On locating-domination sets in infinite grids, *European Journal of Combinatorics* **27** (2006), 218–227.
- [21] I. Honkala, T. Laihonen, and S. Ranto, On strongly identifying codes, *Discrete Mathematics* **254** (2002), 191–205.
- [22] M.G. Karpovsky, K. Chakrabarty and L.B. Levitin, On a new class of codes for identifying vertices in graphs, *IEEE Transactions on Information Theory* IT-44 (1998), 599–611.
- [23] R. Kincaid, A. Oldham, and G. Yu, On optimal open locating-dominating sets in infinite triangular grids, Mar 28 2014 math.CO arXiv:1403.7061v1
- [24] A. Lobstein, Watching systems, identifying, locating-dominating and discriminating codes in graphs, <http://www.infres.enst.fr/lobstein/debutBIBidetlocdom.pdf>.
- [25] J. Moncel, On graphs on n vertices having an identifying code of cardinality $\lceil \log_2(n + 1) \rceil$, *Discrete Applied Mathematics* **154** (2006), 2032–2039.
- [26] S.J. Seo and P.J. Slater, Open neighborhood locating-dominating sets, *Australasian Journal of Combinatorics* **46** (2010), 109–120.
- [27] S.J. Seo and P.J. Slater, Open neighborhood locating-dominating in trees, *Discrete Applied Mathematics* **159** (2011), 484–489.
- [28] S.J. Seo and P.J. Slater, Open neighborhood locating-domination for infinite cylinders, *Proceedings of ACM SE* (2011) 334–335.
- [29] S.J. Seo and P.J. Slater, Open neighborhood locating-domination for grid-like graphs, *Bulletin of the Institute of Combinatorics and its Applications* **65** (2012), 89–100.
- [30] S.J. Seo and P.J. Slater, Graphical parameters for classes of tumbling block graphs, *Congressus Numerantium* **213** (2012), 155–168.
- [31] S.J. Seo and P.J. Slater, Open locating-dominating interpolation for trees, *Congressus Numerantium* **215** (2013), 145–152.
- [32] S.J. Seo and P.J. Slater, OLD Trees with maximum degree three, *Utilitas Mathematica* **94** (2014), 361–380.
- [33] S.J. Seo and P.J. Slater, Fault Tolerant Detectors for Distinguishing Sets in Graphs, *Discusiones Mathematicae Graph Theory*, in press.
- [34] J.L. Sewell, Ph. D. Dissertation, in preparation.
- [35] J.L. Sewell and P.J. Slater, Fault tolerant identifying codes and locating-dominating sets, in preparation.
- [36] P.J. Slater, Leaves of trees, *Congressus Numerantium* **14** (1975), 549–559.

- [37] P.J. Slater, Domination and location in graphs, *National University of Singapore, Research Report* **93** (1983).
- [38] P.J. Slater, Dominating and location in acyclic graphs, *Networks* **17** (1987), 55–64.
- [39] P.J. Slater, Dominating and reference sets in graphs, *Journal of Mathematical and Physical Sciences* **22** (1988), 445–455.
- [40] P.J. Slater, Locating dominating sets and locating-dominating sets. *Graph Theory, Combinatorics, and Applications: Proceedings of the 7th Quadrennial International Conference on the Theory and Applications of Graphs* **2** (1995), 1073–1079.
- [41] P.J. Slater, Fault-tolerant locating-dominating sets, *Discrete Mathematics* **249** (2002), 179–189.
- [42] P.J. Slater, Independent locating dominating sets and independent identifying codes, Submitted for publication.
- [43] D.S. Studer, T.W. Haynes, and L.M. Lawson, Induced-Paired Domination in Graphs, *Ars Combinatoria* **57** (2000), 111–128.