

## Development of Rainfall-runoff Modeling Using a Tank Model: Problems and Challenges in Province of Aceh, Indonesia

Hairul Basri

Faculty of Agriculture, Syiah Kuala University, Banda Aceh, Indonesia

Corresponding author: Email: hairulbasri@gmail.com

---

**Abstract** - Rainfall-runoff modeling using tank model founded by Sugawara has been widely used in Asia. Many researchers use the tank model to predict water availability and flooding in a watershed. This paper describes the concept of rainfall-runoff modeling using tank model, discuss the problems and challenges the use of tank model, especially in Province of Aceh, Indonesia and how to improve the outcome of simulation of tank model. Many factors affect the rainfall-runoff phenomena of a wide range of watershed include: soil type, land use types, rainfall, morphometry, geology and geomorphology, caused the tank model usefull only for concerning watershed. It is necessary to adjust some parameters of tank model for other watershed by recalibrating the observed and simulated discharges. Rainfall runoff modeling using the tank model for a watershed scale is more reasonable focused on each sub-watershed by considering soil types, land use types and rainfall of the concerning watershed. Land use data can be enhanced by using landsat imagery or aerial photographs to support the validation the existing of land use type. Long term of observed discharges and rainfall data should be increased by set up the AWLR (Automatic Water Level Recorder) and rainfall stations for each of sub-watersheds. The reasonable tank model can be resulted not only by calibrating the observed and simulated discharges, but also by considering the observed and simulated infiltration for each soil and land use types of the concerning watershed.

**Key words:** rainfall-runoff modeling, tank model, infiltration, land use types, soil types, watershed

---

### Introduction

Rainfall-runoff modeling is a growing research theme. One of rainfall-runoff modelings is a tank model, introduced by Sugawara, Japan hydrologist, to explain the water flow phenomena of a watershed (Sugawara *et al.*, 1984). At first, the use of tank models only popular in Japan, but due to the tank models were considered simple and proven to provide a good simulation results invite many researchers from outside Japan using tank model to analyze the rainfall-runoff relationship. Many researchers reported tank model has demonstrated its ability to model the hydrologic response of a wide range of watershed. Researches on the use of tank models in Japan (Sugawara *et al.*, 1984; Sugawara, 1961; Basri *et al.*, 1998; Kuroda *et al.* 1999; Basri *et al.*, 1999; Jayadi *et al.*, 1999, Fukuda *et al.*, 1999), in Malaysia (Kuok *et al.*, 2010), in Indonesia (Sutoyo *et al.*, 2003; Basri *et al.*, 2002; Setiawan, 2003; Azmeri *et al.*, 2012) produced a lot of literature on the relationship analysis of rainfall-runoff of watershed. The researchers used the tank model to predict flood and the availability of water in a watershed. The reasonable tank models considered were able to explain the phenomenon of water flow by using rainfall data (as input) and produce discharges as output.

A tank model is a simple concept that uses one or more tanks are illustrated as reservoirs in a watershed that considering rainfall as the input and generate the output as the surface runoff, subsurface flow, intermediate flow, sub-base flow and base flow as output, as well as the phenomenon of infiltration, percolation, deep percolation and water storages in the tank can be explained by the model. The improvement of performances of tank model conducted by trial and error or automatically by comparing the historical discharge (observed discharges) with simulated discharge resulting from tank model (Sugawara, 1961). If the simulated discharges obtained from the tank model and historical discharges have a trend and significant correlations, the simulation is considered successful and the tank model can be used to evaluate the flow phenomena for the concerning watersheds.

There are some problems and challenges in the use of tank models, particularly for Aceh, Indonesia. First is the lack of observed discharges due to the lack of AWLR (Automatic Water Level Recorder) to monitor the daily observed discharges of river at hydrometric station. In general, the AWLR (if available) is set up in the main river outlets and rarely performed for all outlets tributaries of concerning watershed. Second, rainfall data (as input) is not available enough due to the lack of representative of rainfall stations; it may cause the debatable of tank model. Third, the total of

observed discharges used for calibrating the tank model originated from several soil and land use types which are distributed in a wide range of watershed. Various types of land use, for example forests (Lee, 1986) and various types of soil (NRCS, 1986) provide a variety of hydrologic response to rainfall. Therefore, this paper outlines how to improve the tank model to be more reasonable for analysing the rainfall-runoff relationship in a wide range of watershed.

The purpose of this paper is to describe the concept of rainfall-runoff modeling using tank models and discuss the problems and challenges of the use of tank models and how to improve the tank model for analysing the rainfall-runoff relationship in a wide range of watershed.

### Concept of Tank Model

Sugawara (1984) mentioned the tank model is a very simple model, composed one, two, three and four tanks laid vertically in series. Precipitation is put in the top tank, and evaporation or evapotranspiration is subtracted from the top tank. If there is no water in the top tank, evaporation or evapotranspiration is subtracted from the second tank; if there is no water in both the top and the second tank, evaporation or evapotranspiration is subtracted from the third tank; and so on. The output from the side outlets are the calculated runoff. The output from the top tank is considered as surface runoff and sub-surface runoff, output from the second tank as intermediate flow, from the third tank as sub-base flow and output from the fourth tank as base flow. The process of water inflow to soil is considered as infiltration and if the infiltration is constant the percolation is appeared.

Chow *et al.* (1988) mentioned in general, the water balance of a watershed is shown in Equation (1). Based on the general of water balance is then formed several of the water balance for tank model by considering a variety of land uses of watershed.

$$\frac{dS}{dt} = P - ET - Q \dots \dots \dots (1)$$

Where,  $dS/dt$  = fluctuation of water storage (mm/day),  $P$  = precipitation (mm/day),  $ET$  = evapotranspiration (mm/day),  $Q$  = discharge (mm/day)

A watershed has typically comprises several types of land use such as settlement, paddy area, gardens, vacant area and forests. Therefore, each tank model is built by considering the types of land use as shown in Figure 1 to 5. Then the water balance and its components for each tank model are presented in formula 2 to 43 (Sugawara *et al.*, 1984; Basri *et al.*, 1999; Jayadi *et al.*, 1999; Basri *et al.*, 2002). The unit for all components of the water balance is in mm/day.

### Settlement area

Based on the logic of the water flow, a type of land use for settlement area is defined as settlement tank that generally is impermeable to water. Therefore, the tank model is established to represent only the surface flow as shown in Figure 1 (Settlement tank). Water balance and its components for settlement tank are mentioned from formula (2) to (3).

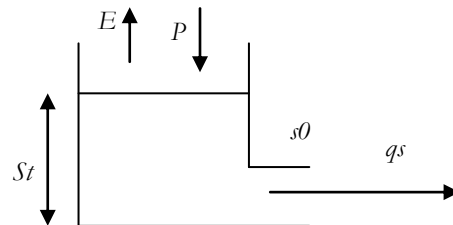

Figure 1. Settlement tank

Water balance for settlement tank:

$$\frac{dSt}{dt} = P - E - qs \dots \dots \dots (2)$$

$$qs = St \times s0 \dots \dots \dots (3)$$

Where,  $dSt/dt$  = fluctuation of water storage in settlement area,  $P$  = precipitation,  $E$  = evaporation,  $St$  = water storage,  $s0$  = coefficient of tank hole,  $qs$  = discharge from settlement tank.

### Paddy area

In general, the paddy area has a hard pan (impermeable layer). Therefore, the paddy tank for paddy area has two layers of tanks (Figure 2). Percolation, surface flow, sub-surface flow and base flow occur in paddy tank. Water balance and its components for paddy tank are shown from formula (4) to (10).

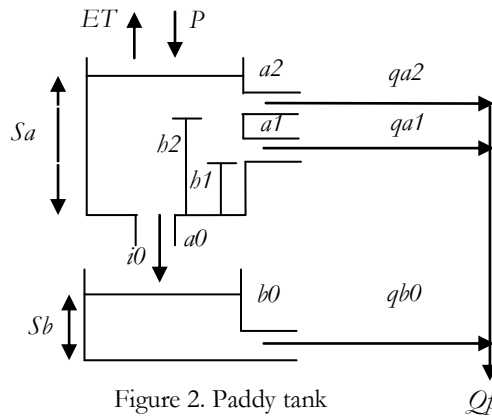

Figure 2. Paddy tank

Water balance for paddy tank:

$$\frac{dS_a}{dt} = P - ET - qa_2 - qa_1 - i_0 \dots\dots\dots (4)$$

$$qa_2 = (S_a - h_2) \times a_2 \text{ if } S_p > h_2; 0 \text{ if } S_p \leq h_2 \dots\dots (5)$$

$$qa_1 = (S_a - h_1) \times a_1 \text{ if } S_p > h_1; 0 \text{ if } S_p \leq h_1 \dots\dots (6)$$

$$i_0 = S_a \times a_0 \dots\dots\dots (7)$$

$$\frac{dS_b}{dt} = i_0 - qb_0 \dots\dots\dots (8)$$

$$qb_0 = S_b \times b_0 \dots\dots\dots (9)$$

$$Q_p = qa_2 + qa_1 + qb_0 \dots\dots\dots (10)$$

Where,  $dS_a/dt$ ,  $dS_b/dt$  = fluctuation of water storages in paddy area; ET=evapotranspiration,  $qa_2$  = surface flow;  $qa_1$ = sub-surface flow;  $qb_0$  = base flow;  $i_0$  = infiltration;  $S_a$ ,  $S_b$  = water storages;  $h_2$ ,  $h_1$  = heights of tank holes;  $a_2$ ,  $a_1$ ,  $a_0$ ,  $b_0$  = coefficients of tank holes,  $Q_p$  = total discharge from paddy tank.

**Vacant area**

The land use of vacant area called as vacant tank is shown in Figure 3. The vacant tank has three layers of tanks. In general, infiltration and percolation occur in vacant area. Water balance and its components for vacant tank are mentioned from formula (11) to (20).

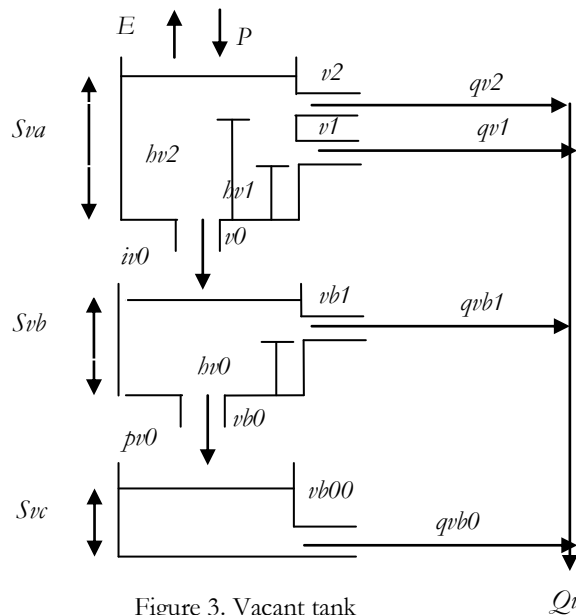

Figure 3. Vacant tank

Water balance for vacant tank:

$$\frac{dS_{va}}{dt} = P - E - qv2 - qv1 - iv0 \dots \dots (11)$$

$$qv2 = (S_{va} - hv2) \times v2 \text{ if } S_{va} > hv2; 0 \text{ if } S_{va} \leq hv2 \dots (12)$$

$$qv1 = (S_{va} - hv1) \times v1 \text{ if } S_{va} > hv1; 0 \text{ if } S_{va} \leq hv1 \dots (13)$$

$$iv0 = S_{va} \times v0 \dots \dots \dots (14)$$

$$\frac{dS_{vb}}{dt} = iv0 - pv0 - qvb1 \dots \dots \dots (15)$$

$$qv1 = (S_{vb} - hv0) \times vb1 \text{ if } S_{vb} > hv0; 0 \text{ if } S_{vb} \leq hv0 \dots (16)$$

$$pv0 = S_{vb} \times vb0 \dots \dots \dots (17)$$

$$qv0 = S_{vc} \times vb00 \dots \dots \dots (18)$$

$$\frac{dS_{vc}}{dt} = pv0 - qvb0 \dots \dots \dots (19)$$

$$Qv = qv2 + qv1 + qvb1 + qvb0 \dots \dots \dots (20)$$

Where,  $dS_{va}/dt, dS_{vb}/dt, dS_{vc}/dt$  = fluctuation of water storages in vacant area;  $qv2$  = surface flow;  $qv1$  = sub surface flow;  $qv0$  = intermediate flow;  $qv0$  = base flow;  $iv0$  = infiltration;  $pv0$  = percolation;  $S_{va}, S_{vb}, S_{vc}$  = water storages;  $hv2, hv1, hv0$  = heights of tank holes;  $v2, v1, v0, vb0, vb1, vb00$  = coefficients of tank holes;  $Qv$  = total discharge from vacant tank.

**Garden area**

The land use of garden area called as garden tank consists of three layers tanks (Figure 4). In general, the infiltration and percolation occur in garden area. Water balance and its components for garden tanks are mentioned from formula (21) to (30).

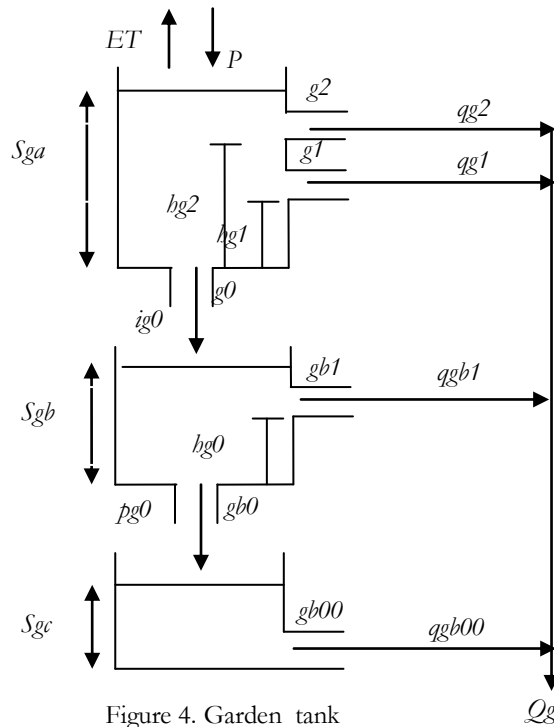

Figure 4. Garden tank

Water balance for garden tank:

$$\frac{dS_{ga}}{dt} = P - ET - qg2 - qg1 - ig0 \dots (21)$$

$$qg2 = (S_{ga} - hg2) \times g2 \text{ if } S_{ga} > hg2; 0 \text{ if } S_{ga} \leq hg2 \dots (22)$$

$$qg1 = (S_{ga} - hg1) \times g1 \text{ if } S_{ga} > hg1; 0 \text{ if } S_{ga} \leq hg1 \dots (23)$$

$$ig0 = S_{ga} \times g0 \dots \dots \dots (24)$$

$$\frac{dS_{gb}}{dt} = ig_0 - pg_0 - q_{gb1} \dots \dots \dots (25)$$

$$q_{gb1} = (S_{gb} - hg_0) \times gb_1 \text{ if } S_{gb} > hg_0; 0 \text{ if } S_{gb} \leq hg_0 \dots (26)$$

$$pg_0 = S_{gb} \times gb_0 \dots \dots \dots (27)$$

$$\frac{dS_{gc}}{dt} = pg_0 - q_{gb00} \dots \dots \dots (28)$$

$$q_{gb00} = S_{gc} \times gb_{00} \dots \dots \dots (29)$$

$$Q_g = q_{g2} + q_{g1} + q_{gb1} + q_{gb00} \dots \dots \dots (30)$$

Where,  $dS_{ga}/dt, dS_{gb}/dt, dS_{gc}/dt$  = fluctuation of water storages in garden area;  $q_{g2}$  = surface flow;  $q_{g1}$  = sub surface flow;  $q_{gb1}$  = intermediate flow;  $q_{gb00}$  = base flow;  $ig_0$  = infiltration;  $pg_0$  = percolation;  $S_{ga}, S_{gb}, S_{gc}$  = water storages;  $hg_2, hg_1, hg_0$  = heights of tank holes;  $g_2, g_1, g_0, gb_1, gb_0, gb_{00}$  = coefficients of tank holes;  $Q_{vg}$  = total discharge from garden tank.

**Forest area**

In general, the forest area has a deep of soil solum. Infiltration, percolation and deep percolation occur in forest area. Therefore, the forest area defined as forest tank has 4 layers (Figure 5). Water balance and its components for forest tanks are shown from formula (31) to (43).

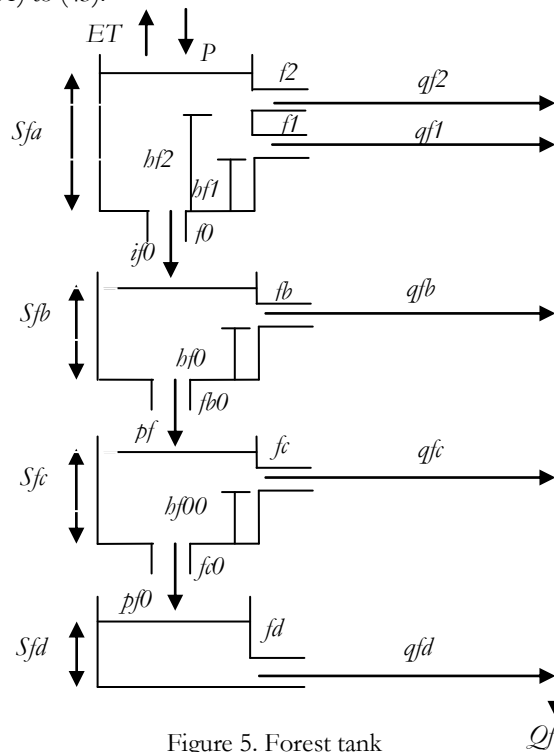

Figure 5. Forest tank

Water balance for forest tank:

$$\frac{dS_{fa}}{dt} = P - ET - q_{f2} - q_{f1} - if_0 \dots \dots \dots (31)$$

$$q_{f2} = (S_{fa} - hf_2) \times f_2 \text{ if } S_{fa} > hf_2; 0 \text{ if } S_{fa} \leq hf_2 \dots (32)$$

$$q_{f1} = (S_{fa} - hf_1) \times f_1 \text{ if } S_{fa} > hf_1; 0 \text{ if } S_{fa} \leq hf_1 \dots (33)$$

$$if_0 = S_{fa} \times f_0 \dots \dots \dots (34)$$

$$\frac{dS_{fb}}{dt} = if_0 - pf - q_{fb} \dots \dots \dots (35)$$

$$qfb = (Sfb - hf0) \times fb \text{ if } Sfb > hf0; 0 \text{ if } Sfb \leq hf0 \dots (36)$$

$$pf = Sfb \times fb0 \dots \dots (37)$$

$$\frac{dSfc}{dt} = pf - pf0 - qfc \dots \dots (38)$$

$$qfc = (Sfc - hf00) \cdot fc \text{ if } Sfc > hf00; 0 \text{ if } Sfc \leq hf00 \dots (39)$$

$$pf0 = Sfc \times fc0 \dots \dots (40)$$

$$\frac{dSfd}{dt} = pf0 - qfd \dots \dots (41)$$

$$qfd = Sfd \times fd \dots \dots (42)$$

$$Qf = qf2 + qf1 + qfb + qfc + qfd \dots \dots (43)$$

Where,  $dSfa/dt, dSfb/dt, dSfc/dt, dSfd/dt$  = fluctuation of water storages in forest area;  $qf2$  = surface flow;  $qf1$  = sub surface flow;  $qfb$  = intermediate flow;  $qfc$  = sub base flow;  $qfd$  = base flow;  $if0$  = infiltration;  $pf$  = percolation,  $pf0$  = deep percolation;  $Sfa, Sfb, Sfc, Sfd$  = water storages;  $hf2, hf1, hf0, hf00$  = heights of tank holes;  $f2, f1, f0, fb, fb0, fc, fc0, fd$  = coefficients of tank holes;  $Qf$  = total discharge from forest tank.

### Calibration of Model

In general, the calibrated discharge is the total discharges from each land use of concerning watershed with the assumption that all discharges originated from all of land use types will appear in the river at the point of reference (outlet). Total discharges as shown in equation (44) becomes the deciding factor on the reasonable of the tank model.

$$Qt = Qs + Qp + Qv + Qg + Qf \dots \dots \dots (44)$$

Where,  $Qt$  = total discharges in the river,  $Qs$  = total discharge from settlement tank,  $Qp$  = total discharge from paddy tank,  $Qv$  = total discharge from vacant tank,  $Qg$  = total discharge from garden tank,  $Qf$  = total discharge from forest tank.

There are two methods used to calibrate the results of the simulation. First is trial and error by changing the values of parameters such as the initial storages, height of tank and coefficients of tank holes. If the simulated discharge has a similar trend and has a strong correlation with observed discharge, the tank model is considered reasonable to describe the flow phenomena of concerning watershed. However, if the calibration results are still not reasonable then the work is repeated by changing all values of tank parameter. The trial and error method takes times and more difficult than the second method known as automatical callibration using computer program (PASCAL, BASIC, FORTRAN, and etc.). Using the computer program, the calibration work becomes easy and fast.

Model calibration can be done by minimizing the value of objective function J (Jayadi *et al.*, 1999) as shown in equation (45). Furthermore, there are also other researchers to test its accuracy by using the model of Nash and Sutcliffe (1970) as presented in equation (46). The use of correlation test is often used by researchers to analyze the relationship between observed and simulated discharges as presented in equation (47).

$$J = \frac{1}{n} \sum_{i=1}^n \frac{|Qo - Qs|}{\sqrt{Qs}} \dots \dots \dots (45)$$

Where,  $n$  = number of observation,  $Qo$  and  $Qs$  = the actual and the simulated discharges ( $m^3/s$ ) in the  $i^{th}$  of concerning calculation period, respectively.

$$NSE = 1 - \frac{\sum_{i=1}^n (Qo(i) - Qs(i))^2}{\sum_{i=1}^n (Qo(i) - Qao(i))^2} \dots \dots \dots (46)$$

Where,  $Qo$  = Observed discharge ( $m^3/s$ );  $Qs$  = Simulated discharge ( $m^3/s$ ); dan  $Qao$  = Average of observed discharge ( $m^3/s$ ); Value of  $NSE$  between  $-\infty$  and 1, and if value of  $NSE = 1$  defined as the complete of simulation.

$$R = 1 - \frac{\sum_{i=1}^n (Qo(i) - Qao(i))(Qs(i) - Qas(i))}{\sqrt{\sum_{i=1}^n (Qo(i) - Qao(i))^2 \sum_{i=1}^n (Qs(i) - Qas(i))^2}} \dots \dots \dots (47)$$

Where,  $Qo$  = Observed discharges ( $m^3/s$ ),  $Qao$  = average of observed discharge ( $m^3/s$ ),  $Qs$  = simulated discharge ( $m^3/s$ ),  $Qas$  = average of simulated discharge ( $m^3/s$ ),  $n$  = number of observation,  $R$  = regression coefficient ( $-1 \leq R \leq 1$ )

## **Problems and Challenges**

Many factors affect the rainfall-runoff phenomena in a wide range of watershed such as soil type, land use types and rainfall as illustrated in Figure 6. In general, the influences of these factors are ignored. Researchers may think that they do not have a significant effect to the performance of tank model or the discussion of their influence is complicated. Therefore, some factors such as soil type, land use types and rainfall are interesting to discuss for improving the validity of the tank model.

### **Soil type**

The watershed has some soil types distributed throughout the watershed. Five major of watersheds (Aih Tripe, Krueng Aceh, Lawe Alas, Krueng Pase and Krueng Peusangan) in province of Aceh, Indonesia, for example, have several of soil types such as Inceptisol, Andisol, Entisol, Ultisol and Histosol. Each of these soil types has a special soil property (for example soil solum, texture, structure, and organic matter), which are different from others. The infiltration and runoff phenomena of a wide range of watershed are affected by the soil property. NRCS (1986) classified the soil hydrology according to the soil properties and minimum infiltration rate. There are four classifications of soil hydrology (A, B, C, and D) as follows: (1) soil hydrology of A has low potency of surface runoff; dominated by a deeper sandy soil with silt and clay; and high infiltration rate (8-12 mm/h), (2) B has low potency of surface runoff; sandy soil more lower than class A, soil texture from fine to medium; and moderate infiltration rate (4-8 mm/h), (3) C has moderate potency of surface runoff; lower soil solum contained enough clay, soil textures from fine to medium, low infiltration rate (1-4 mm/h), and (4) D has high potency of surface runoff; lower soil clay with impermeable layer close to surface soil, and very low infiltration rate (0-1 mm/h).

Sutoyo *et al.* (2003) who conducted a study on prediction of river discharge in Cidanau Watershed, Serang Indonesia considered the observed infiltration to determine the magnitude of the coefficient of infiltration of tank models. Observed infiltration in the field collected by using a double ring infiltrometer was the right way to determine the infiltration capacity. However, the study did not report the significance of the observed and simulated infiltration originated from the tank model for all of land used and soil types in the concerning watershed.

Tank model calibrations usually pay less attention to the differences of the infiltration rate due to the heterogeneity of land use and soil types in a watershed. The assumption that they are similar to a wide range of watershed may be giving a bias of simulated results. Therefore, the calibration between the observed infiltrations and simulated infiltration needs to be done to support more accurately the calibration of the simulated and observed discharges at reference point of hydrometric station.

### **Land use type**

A watershed with different types of land use is distributed throughout the watershed; even a sub-watershed has also a different of land use types. In the use of the tank model, various types of land use as a reference to determine the number of tank model. For some case studies in Indonesia, analysis of land use types using the land use maps issued by the relevant agencies such as BPN (National Land Agency). Land use maps can help to analyze the historical land use of the watershed, but the existing of land use need to validate by using the data of landsat imagery or aerial photography as well as by conducting the ground check in a watershed. Furthermore, the forest area, for example, which has a variety of density of forest stand within a watershed, is also a particular challenge in analyzing rainfall runoff modeling using the tank model. Many published studies have lack of information on considering the density of the forest stands for the tank model. However, the density of forest stands has different capabilities to response the rainfall in the concerning watershed (Lee, 1980). Good vegetation has the ability to protect the soil surface from raindrop impact and reduces the rate of surface runoff so as to reduce the rate of erosion (Ward and Elliot, 1995). In other words, the land without vegetation will be susceptible to erosion which cause impaired infiltration process thereby increasing runoff. To overcome this problem, adjusting the parameters of the model tanks, especially coefficient of tank holes for infiltration is more reasonable in accordance with the magnitude of the observed infiltration rate as reported by Sutoyo *et al.* (2003).

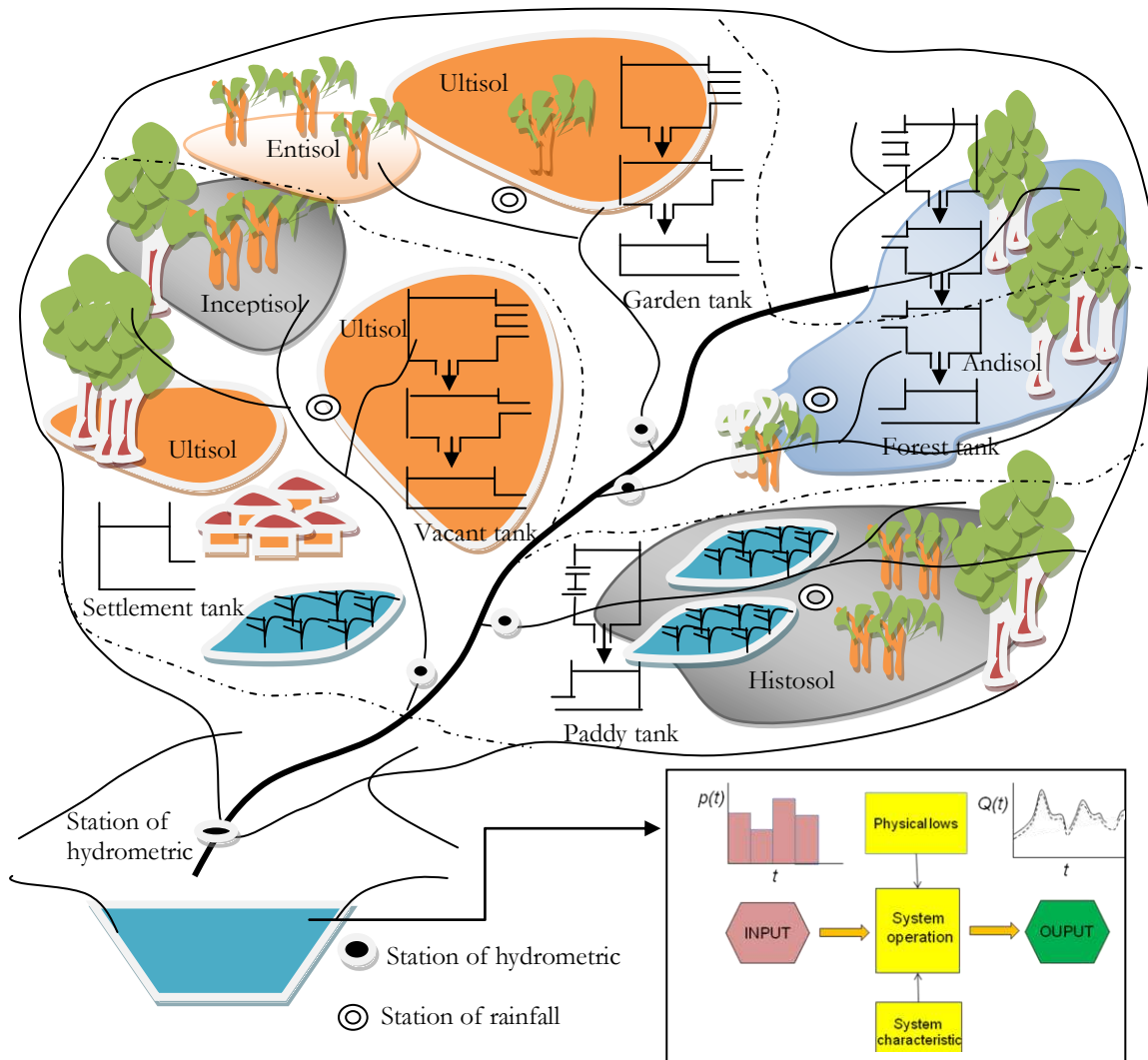

Figure 6. Illustration of complex tank model established base on land use types of a watershed

### Rainfall

Daily rainfall data, as input component, is very important in evaluating rainfall-runoff modeling using the tank model. A tank model for a watershed scope that consists of several sub-watersheds will be biased if the rainfall data is only represented by one unit of rainfall station. In a wide range of watershed, the daily rainfall and intensity of rainfall are usually not uniformly distributed across the watershed. Furthermore, the problems faced especially in Indonesia are the unavailability of sufficient rainfall station that can provide information of the long term of daily rainfall. The recording of daily rainfall is done manually due to the unavailability of automatic rainfall recorder.

Several main watersheds in the Province of Aceh, Indonesia have variety of yearly average rainfall such as the watershed Aih Tripe (1725 mm), Krueng Aceh (1357 mm), Lawe Alas (1978 mm), Krueng Pase (1490 mm) and Peusangan (1005 mm). Generally, there is only one unit of rainfall stations on the concerning watershed, while each of watersheds has several sub watersheds. The intensity of rainfall in the watershed is predicted by using the Mononobe method because there is no automatic rainfall recorder.

Information about the intensity of rainfall is important to look at the relationship between rainfall and infiltration as well as surface runoff in the watershed. Chow, *et al.* (1988) mentioned that surface runoff will occur if the rain intensity is higher than the rate of infiltration. This is a challenge how to set up parameters of tank model which can explain the effect of rainfall intensity on the timing of surface runoff.



Rainfall runoff modeling using a tank model becomes more complicated when examined further by analyzing the effect of rainfall intensity on infiltration and surface runoff in a watershed. Rainfall intensity over 60 mm/h has the ability to damage the soil structure in the region that does not have good cover crops. The damaged soil structure can cause splash erosion processes that inhibit water infiltration into the soil (Brooks *et al.*, 2003). The diversities of soil types and land use distributed throughout the watershed have different responses to rainfall which can cause erosion in the Sub watershed of Krueng Jrue, Province of Aceh, Indonesia (Edwarsyah *et al.*, 2002). However, researchers who use tank models today have not yet considered the phenomenon of the rainfall intensity. Therefore, the construction of the rainfall station at least one unit for each sub-watershed is necessary to produce a reasonable of tank model.

### Observed discharge

Observed discharges are very important for calibrating the tank model. Generally in Indonesia, the historical flow data obtained from the Department of Water Resources, the government agency that is responsible for the development of water resources. Long-term historical observed discharges (minimum 10 years) are necessary for calibrating the simulated discharges generated by the tank model.

The availability of long-term historical discharges is a problem for researchers in Indonesia to develop the tank model. This is not only due to the lack of available historical discharges, but also the daily discharges are often incomplete. Furthermore, there is only one unit of hydrometric station for each watershed, which is generally set up in the main river. Similar cases for rainfall stations, hydrometric station which aims to record the daily discharge is not yet available for each sub-watershed. Therefore, hydrometric stations need to be set up in each sub-watershed to support research for rainfall-runoff modeling in Indonesia, supported by tool called AWLR (Automatic Water Level Recorder) as illustrated in Figure 6. By using AWLR the daily discharges will be available and valid to support the development of tank models in the future.

### Parameters of Tank Model

A reasonable of tank model can be used to analyze the relationship between rainfall and runoff for the concerning watershed. The tank model cannot be used for other watersheds due to different characteristic properties such as soil type, land use, watershed morphometry, geology and geomorphology of watershed. However, the values of parameters of the tank model were reported by other researchers can be used as references for examples: the initial values of storages, heights of tank, and coefficients of tank holes as well as the number and layers of tank model. Some values of the parameters of the tank model used by some researchers presented in Tables 1, 2 and 3.

The phenomenon of water flow in a watershed produced by Tank Model is determined by the parameters of tank model (Table 1). Sugarawa *et al.* (1984) provided general information that infiltration in Japan watershed ( $f_0$ ) of 0.2 or 20 percent of fluctuated water storages (after subtracted by evapotranspiration) of the first tank. Furthermore, the total of simulated discharges obtained from the sum of all coefficients of tank holes to the side ( $f_2, f_1, f_b, f_c, f_{c0},$  and  $f_d$ ) was 0.46. Basri *et al.* (2002) reported coefficient of infiltration of the Sub Watershed of Krueng Jrue, Aceh Indonesia was 0.36 and total coefficients of tank holes to the side was 0.48. Setiawan *et al.* (2003) reported the coefficient of infiltration of the Cidanau Watershed Indonesia was 0.20 and total coefficients of tank holes to the side was 0.30. The values of the tank model parameters were reasonable. However, Kuok *et al.* (2010) provided different information where Bedup Watershed in Malaysia had the coefficient of infiltration 0.00024, and the total coefficients of tank holes to the side was 1.46. Sugawara *et al.* (1984) mentioned the total coefficient of tank holes to the side should not bigger than 1(one), because it is not reasonable if 100 persen of fluctuated water storages in the tank model will appear as discharges in the river.

Parameters of tanks on the basis of land use are presented in Tables 2 and 3. Basri *et al.* (2002) reported that the value of infiltration for forest tank was higher than thicket tank. Otherwise the value of surface runoff from forest tank was lower than the value of surface runoff generated by thicket tank (Table 2). Azmeri *et al.* (2012) reported the forest area had a good ability to produce water reserves in the soil compared with other land uses. In contrast, the use of vacant area, settlement area and paddy area tend to have high values of surface runoff compared to forest area and garden area (Table 3). The parameters for the coefficients tank holes for infiltration were influenced by soil types, land use types, and rainfall intensity. Therefore, it is necessary to consider the infiltration values for calibration of the observed and simulated discharges of the tank model.

Table 1. Parameters of four layers of tank model used by researchers

Four layer tank model	General watershed in Japan (Sugawara <i>et al.</i> , 1984)				Bedup watershed in Malaysia (Kuok <i>et al.</i> , 2010)				Krueng Jreue Sub Watershed Indonesia (Basri <i>et al.</i> , 2002)				Cidanau watershed Indonesia (Setiawan, 2003)				Components of water balance
	Height of tank holes (mm)		Coefficients of tank holes		Height of tank holes (mm)		Coefficients of tank holes		Height of tank holes (mm)		Coefficients of tank holes		Height of tank holes (mm)		Coefficients of tank holes		
first tank	hf2	25	f2	0.2	hf2	18.42	f2	0.04	hf2	30	f2	0.15	hf2	25	f2	0.10	surface flow sub surface flow infiltration
	hf1	15	f1	0.2	hf1	12.95	f1	0.27	hf1	10	f1	0.10	hf1	15	f1	0.10	
			f0	0.2			f0	0.00024			f0	0.36			f0	0.20	
second tank	hf0	15	fb	0.05			fb	0.00166	hf0	30	fb	0.17	hf0	15	fb	0.03	intermediate flow percolation
			fb0	0.01			fb0	0.00358			fb0	0.125			fb0	0.06	
third tank	hf0	15	fc	0.01			fc	0.99	hf00	30	fc	0.035	hf00	15	fc	0.06	sub base flow deep percolation
	0		fc0	0.01			fc0	0.0565			fc0	0.025			fc0	0.012	
forth tank			fd	0.01			fd	0.1052			fd	0.002			fd	0.001	base flow

Table 2. Parameters of tank model based on land use types in Krueng Jreue sub watershed, Province of Aceh, Indonesia (Basri *et al.*, 2002)

Tank types	Water storages (mm)	Height of tank (mm)	Hole of tank	Components of water balance			
<b>Forest tank</b>							
first tank	Sfa	5	hf2	30	f2	0.015	surface flow
			hf1	10	f1	0.10	sub surface flow
					f0	0.375	infiltration
second tank	Sfb	10	hf0	30	fb	0.17	intermediate flow
third tank	Sfc	100	hf00	25	fb0	0.10	percolation
					fc	0.05	sub base flow
forth tank	Sfd	300			fc0	0.025	deep percolation
					fd	0.005	base flow
<b>Thicket tank</b>							
first tank	Sfa	5	hf2	30	f2	0.40	surface flow
			hf1	10	f1	0.10	sub surface flow
					f0	0.10	infiltration
second tank	Sfb	10	hf0	30	fb	0.10	intermediate flow
third tank	Sfc	100	hf00	25	fb0	0.010	percolation
					fc	0.05	sub base flow
forth tank	Sfd	300			fc0	0.025	deep percolation
					fd	0.005	base flow

Table 3. Parameters of tank model based on land use types in Krueng Meuredue Watershed, Province of Aceh, Indonesia (Azmeri *et al.*, 2012)

Tank types	Water storages (mm)	Height of tank (mm)	Coefficient of tank holes	Components of water balance			
<b>Settlement tank</b>							
first tank	St	40	s0	0.88	surface flow		
<b>Paddy tank</b>							
first tank	Sa	200	h2	180	a2	0.67	surface flow
			h1	92	a1	0.001	sub surface flow
second tank	Sb	170			a0	0.15	infiltration
					b0	0.003	base flow
<b>Vacant tank</b>							
first tank	Sva	50	hv2	45	v2	0.78	surface flow
			hv1	10	v1	0.0001	sub surface flow
					v0	0.11	infiltration
second tank	Svb	50	hv0	45	vb1	0.0006	intermediate flow
					vb0	0.0001	percolation
third tank	Svc	40			vb00	0.0001	base flow
<b>Garden tank</b>							
first tank	Sga	55	hg2	44	g2	0.57	surface flow
			hg1	35	g1	0.05	sub surface flow
					g0	0.21	infiltration
second tank	Sgb	67	hg0	43	gb1	0.0002	intermediate flow
					gb0	0.007	percolation
third tank	Sgc	55			gb00	0.001	base flow
<b>Forest tank</b>							
first tank	Sfa	200	hf2	50	f2	0.011	surface flow
			hf1	40	f1	0.09	sub surface flow
					f0	0.25	infiltration
second tank	Sfb	98	hf0	36	fb	0.021	intermediate flow
					fb0	0.0078	percolation
third tank	Sfc	77	hf00	73	fc	0.018	sub base flow
					fc0	0.01	deep percolation
forth tank	Sfd	400			fd	0.001	base flow

## Conclusions

Problems and challenges in the analysing rainfall-runoff modeling using tank model in Province of Aceh, Indonesia are the lack of observed discharges and rainfall data as well as the heterogeneity of a wide range of watershed such as soil types, land use types and rainfall intensity. Land use data can be enhanced by using landsat imagery or aerial photographs to support the validation the existing of land use type. Long term of observed discharges and rainfall data should be increased by set up the AWLR (Automatic Water Level Recorder) and rainfall stations for each of sub-watersheds. Rainfall runoff modeling using the tank model can only be used for concerning watershed and more reasonable focused on each sub-watershed by considering soil types, land use types and rainfall of the concerning watershed. The reasonable tank model can be resulted not only by calibrating the observed and simulated discharges, but also by considering the observed and simulated infiltration for each soil and land use types of the concerning watershed.

## References

### References

- Azmeri, Basri, H., and Herissandy, N. (2012). Changing land use impact analysis toward water availability on Krueng Meureudu watershed. *Journal of Ekonomi dan Pembangunan*, 5 (1): 83-98.
- Basri, H., Fukuda, T., and Kuroda, M. (1998). Water balance and water Quality analysis of paddy field irrigation system in low lying area. *J. Fac. Agr, Kyushu Univ.*, 43(1-2): 222-237.

- Basri, H., Nakano, Y., Kuroda, M., and Funakoshi, T. (1999). Water requirement analysis of paddy field irrigation system in diversified land use area. *J. Fac. Agr, Kyushu Univ.*, 44(1-2): 175-187.
- Basri, H., Syahrul and Nursidah. (2002). Evaluation of hydrological response of Krueng Jreue watershed using computer simulation of tank model. *Jurnal Agrista*, 6 (1): 7-18.
- Brooks, K.N., Ffolliott. P.F., Gregersen, H.M., and DeBano, L.F. (2003). *Hydrology and the management of watersheds*. Iowa State. Blackwell Publishing Company, USA.
- Chow, V.T., Maidment, D.R., and Mays, L.W. (1988). *Applied hydrology*. McGraw-Hill, International Edition, New York, USA.
- Edwarsyah, Basri, H., and Fajri. (2002). Study of erosion effect on soil productivity decreases: case of Krueng Jreue sub-watershed Aceh Besar. *Jurnal Agrista*, 6(1): 7-18.
- Fukuda, T., Jayadi, R., Nakano, Y., and Kuroda, M. (1999). Application of complex tank model for evaluating performance of water operation in a Reused water irrigation system. *J. Fac. Agr., Kyushu Univ.*, 44 (1-2): 189-198.
- Jayadi, R., Fukuda, T., Nakano, Y., and Kuroda, M. (1999). Evaluation of Reused water effect on irrigation water quality of low-lying paddy area. *J. Fac. Agr, Kyushu Univ.*, 44(1-2): 199-211.
- Kuok, K.K., Harun, S., and Shamsudddin, S.M. (2010). Global optimization of the hydrologic tank model's parameters. *Canadian Journal on Civil Engineering*, 1(1): 1-14.
- Lee, R. (1980). *Forest hydrology*. Columbia University Press, New York, USA.
- Kuroda, M., Nakano, Y., Basri, H., and Funakoshi, T. (1999). Analysis of intake water of agricultural water use operated under traditional water right in Japan. *J. Fac. Agr, Kyushu Univ.*, 44 (1-2): 149-156.
- Nash J.E., and Sutcliffe, J.V. (1970). River flow forecasting through conceptual Models, 1, a discussion of principles. *Journal of Hydrology*, 10 (1): 282-290.
- Natural Resources Conservation Service. (1986). *Conservation engineering division. Technical release 55 . Urban Hidrologi for Small Watershed*, US Departement of Agriculture, Washington.
- Setiawan, B. I. (2003). Optimization of tank model's parameters. *Bulletin Keteknikan Pertanian*, 17(1): 8-16.
- Sugawara, M., Watanabe, E. Ozaki, E., and Katsuyama, Y. (1984). Tank model with snow component. The National Research Center for Disaster Prevention, Science and Technology Agency, Japan.
- Sugawara, M. (1961). Automatic callibration of tank model. *Hydrological Sciences-Bulletin-des Sciences Hydrologiques*, 24(3): 375-388.
- Sugawara, M. (1961). On the analysis of runoff structure about several Japanese River. *Japanese Journal of Geophysic*, 4 (2): 1-76.
- Sutoyo, Yanuar, M., and Purwanto, J. ( 2003). River runoff prediction based on rainfall data using tank model. *Bulletin Keteknikan Pertanian*, 13 (3): 25-39.
- Ward, A.D., and Elliot, W.I. (1995). *Environmental hydrology*. Lewis Publishers, CRC Press Inc., New York.