Befizel, Learning Physics by Using Puzzle as Learning Media Innovation

Umi Muslikhah¹, Lita Rahmasari²

Physics Education

Faculty of Teacher Training and Education, Sebelas Maret University, Indonesia

Email: umimuslikhah8@gmail.com

Abstract: Learning media has a very important role in learning process of students. BEFIZEL is one of learning media innovation. Due to the design of collaboration on BEFIZEL children's games, technology and material physics puzzle design that is packed in. By using befizel as learning media will give a new color in the learning process. BEFIZEL consists of puzzle board (batteries, LED: Light-Emitting Diode, switches, cables and PCB, Printed Circuit Board) and design drawing. BEFIZEL can stimulate memory and intelligence of the learners so that learners can easily understand the material in the design puzzle.

Keywords: *BEFIZEL, learning media, Learning Media Innovation, Puzzle*

1. INTRODUCTION

The development technology gives positive effect to all of human life aspect, including education. Technology extends many effects for education. In Indonesia, education becomes the basic foundation of development. There are so many innovations in education which is developed to gain better education.

Education becomes a developmental parameter of a nation. Thus, the improvement of education is very important. One way, to increase education quality by the use of learning media will give effect in physics learning activity. There are many junior and senior high school student faced difficulties in learning in learning physics for that reasons.

By the learning media, hoping that the students can easily learn physics. On the other hand, the use of LED series in puzzle board can stimulate student curiosity in technology through learning physics. Many scientist can born from Indonesia in the future. Learning media that use to learning in class is called Befizel.

Puzzle is a game that can develop children accuracy and intelligence by continuously plays it. Slow but sure children mental will accustom to be calm, diligent and patient in getting things done. Satisfaction is gained when he completes

the jigsaw puzzle become a motivation for the child. Furthermore, playing the jigsaw puzzle will train children's memory about the shape and color of jigsaw puzzle. Children will automatically remember the image that has been seen before he/she arranges the puzzle well.

There are some opinions that define learning. "Learning means an activity that designed to help a person to learn some skills and or new values." (Syaiful Sagala, 2006: 61). Meanwhile, according to Dimiyati and Mudjiono (2006: 297) learning is a set of teacher activities is program in instructional design to make students learn actively, which emphasizes the provision of learning resources. Physics is the science of nature, which studies about the basic elements of the universe, the forces works, and its consequences; covers wide range: from subatomic forming particles and the behavior of the universe as whole cosmos

Mohammed Ali said that learning media take an important role in the learning process. Using of teaching-learning media can help educators in conveying the material to be covered. The function of media in teaching-learning activity is to increase the students' stimulation in teaching. Thus, Befizel can be used as physics learning media.

2. MAIN BODY

Befizel is an innovative learning medium that combines two things. Children's games and technology. Befizel puzzle board fully equipped with cables, electric switch and LED series.

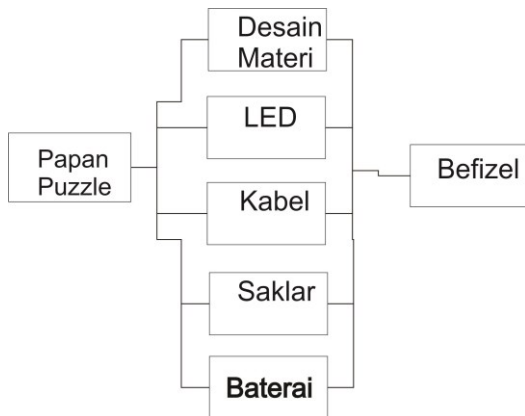

Figure 1. Layout befizel

2.1. Puzzle boards

The main part of this Befizel is a puzzle board. The puzzle board will be equipped with LED design. These LEDs are used as indicator during setup puzzle. When the parts of the puzzle correctly set in the right place, then the LED will light up. The addition of innovation in this kind of circuit board puzzle in order to arise the students' curiosity on how to assemble the puzzle correctly. So that, students will be enthusiasm in learning physics.

The following schematic of LED circuit boards puzzle:

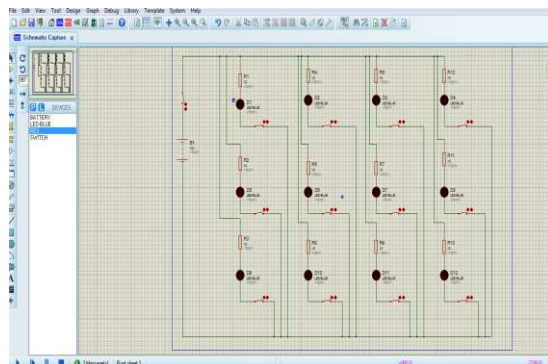

Figure 2. The design scheme of the circuit board puzzle.

Based on the LED circuit design, there are two kinds of series in befizel. The first circuit will be installed on the board and the other in the pieces of puzzle. Battery, wires, switches, cables and PCB will be installed on the board. 3 volts battery power is used for the befizel circuit. Befizel battery installation could be placed on the side or at the bottom of the puzzle board. The electric switch will be installed on the board and the pieces of the puzzle. Installation of the electric switch on each piece of the puzzle must be in different location. In the puzzle pieces mounted LEDs and resistors.

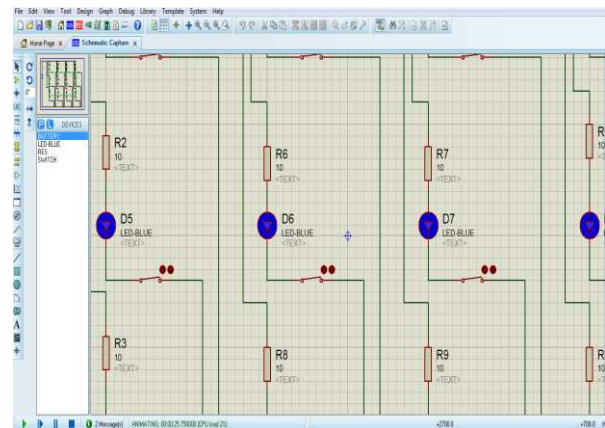

Figure 3. The LED lights up when the puzzle correct pairing.

2.2. Material design

Befizel uses design jigsaw puzzle which contains material physics. This image design as a puzzle-solving activity makes it possible to generate new ideas, to think something different, to be able to integrate knowledge and imagination give birth in creative thinking. So with a design that involves physical materials, learners gain new knowledge.

Befizel design can be adapted to the material to be in teaching for learners. Befizel the following example:



Figure 4. Design of time dilation

2.3. Befizel

Befizel can be made in a number of pieces of the puzzle that diverse. For example, in the design of a series of pieces of the puzzle number is 12. The number of pieces of the puzzle on befizel can be changed as needed when learning takes place. For LEDs used also with different colors to make it more attractive,

Befizel can be used as a medium of learning while using model learning of quantum learning. Besides, befizel give benefit to learners and educators. For students, befizel can facilitate the learning process. Due to the design befizel made different from learning other media. Befizel combination of children's games are packed into an attractive teen world. Indirectly, the students will be happy first even if the materials are teaching will be difficult

Befizel give benefits for educators that educators will be motivated to develop themselves create learning media innovation. One of the success factors of learning lies in the media used. In addition, educators can utilize befizel as a medium of learning for material physics.

3. CONCLUSION

In general, the use of Befizel, beneficial helps students to learn physics. Befizel was designed in such a way and innovative. The addition of the LED on the puzzle board make it more attractive. Befizel so it can be used as an interesting and innovative media to learn physics.

Disadvantages of befizel is that the costs used to design this kind of learning media is quite expensive.

4. ACKNOWLEDGMENT

Befizel manufacture is supported by Grant PKM Dipa UNS 2015 Programe (PKM - K, June 7, 2015

5. REFFENCES

- Ali, Muhammad. 2009. *Development of Media Interactive Learning Courses Electromagnetic Fields*. Vol. 5, No. 1, March 11-18 pages.
- Dimiyati and Mudjiono . 2006. *Teaching and Learning*. Jakarta: Rineka Reserved.
- Sagala , Syaiful , 2006. *The concept and meaning of learning*. Bandung: Alfabeta
- Serway, Raymond A. 2010. *Physics for Science and Engineering*. Jakarta: Salemba Teknika