

STRESS ANALYSIS OF REDUCED BEAM SECTION STEEL MOMENT CONNECTION (AISC 358-2005)

Kukuh Kurniawan Dwi Sungkono

Department of Engineering, Universitas Tunas Pembangunan Surakarta

Email : kukuhkds.utpska@gmail.com

Received Date: May 22, 2017 Approved Date: July 20, 2017

ABSTRACT

Earthquakeresistant building structures should be properly and appropriately designed, especially in the planning and detailing of the beam - column connections. The collapse mechanism of seismic building shall occur plastic hinge first and the column is still in elastic condition (strong column weak beam). AISC 358-2005 provides type of steel connection for seismic building. In the regulation mentioned that the connection is used in the structure with the Special Moment Frames (SMF) and Intermediate Moment Frames (IMF), one of the connection types is reduced beam section. Reduced Beam Section (RBS) moment connection, portions of the beam flanges are selectively trimmed in the region adjacent to the beam to column connection. Result modeling RBS on FEM, the top of the beam occur tensile strength 1367kN/m², the bottom of the beam has a compressive stress 2943kN/m², the beam web has a tensile stress 1281kN/m², the face of the column occur tensile stress 667kN/m² and the column web 857kN/m². The shear stress in the beam web is largest (857kN/m²) than on the beam flange (275kN/m²), and the shear stress on the column is smaller (503kN/m²).

Keyword: *Reduced Beam Section, SMF, IMF, Finite Element Method*

ABSTRAK

Struktur bangunan tahan gempa harus dirancang dengan benar dan tepat, terutama dalam perencanaan dan pendetailan sambungan balok-kolom. Mekanisme keruntuhan struktur bangunan gempa harus terjadi sendi plastis terlebih dahulu dan kolomnya masih dalam kondisi elastis (strong column weak beam). AISC 358-2005 menyediakan jenis sambungan baja untuk bangunan seismik. Dalam peraturan tersebut disebutkan bahwa sambungan tersebut digunakan untuk struktur Rangka Momen Khusus (RMK) dan Rangka Momen Menengah (RMM), salah satu jenis sambungan adalah bagian Penampang Balok Tereduksi. Sambungan Penampang Balok Tereduksi (RBS) adalah sebagian sayap balok dipangkas secara selektif di wilayah yang berdekatan dengan sambungan balok-kolom. Hasil pemodelan RBS pada FEM, bagian atas balok terjadi pada tegangan tarik 1367kN/m², bagian bawah balok memiliki tegangan tekan 2943kN/m², badan balok memiliki tegangan tarik 1281kN/m², muka kolom terjadi tegangan tarik 667kN/m² dan badan kolom 857kN/m². Tegangan geser pada badan balok adalah yang paling besar (857 kN / m²) dibandingkan sayap balok (275kN/m²), dan tegangan geser pada kolom lebih kecil (503 kN/m²).

Kata kunci: *Penampang Balok Tereduksi, RMK, RMM, Metode Elemen Hingga*

1. Introduction

Earthquake resistant building structures should be properly and appropriately designed, especially in the planning and detailing of the beam-column connections. Reflect on the earthquake that occurred in 1994 at Northridge-California and 1995 in Kobe-Japan, there is a lot of damage in connections of the steel moment resisting frame. In strong earthquake conditions, where collapse mechanisms can damage structural and non-structural elements (plastic hinge collapse mechanism), but the building did not collapse. It is called the collapse mechanism of global, or strong column - weak beam, where the beam ends in a plastic hinge.

In the hope of experiencing a strong column (weak column-weak beam) mechanism in the event of an earthquake, a variety of ways are made to reach the plastic condition at the end of the beam. To achieve the condition of plastic joints at the end of the beam is done in various ways, one of them by weakening the end of the beam. With the aim of a strong earthquake the end of the beam occurs plastic hinge first and the column is still in elastic condition.

AISC 358-2005 provides type of steel connection for seismic building. In the regulation mentioned that the connection is used in the structure with the Special Moment Frames (SMF) and Intermediate Moment Frames (IMF). The connection types are as follows:

- a. Reduced Beam Section (RBS)
- b. Bicep Unstiffened Extended End Plate (BUEEP)
- c. Connection-Ended Edge Plate Bolted and With Straightener (Bolt Stiffened Extended End Plate/ BSEEP)

Reduced Beam Section (RBS) moment connection, portions of the

beam flanges are selectively trimmed in the region adjacent to the beam to column connection. Yielding and hinge formation are intended to occur primarily within the reduced section of the beam. RBS connections are pre-qualified for use in special moment frame (SMF) and intermediate moment frame (IMF) system within the limits.

2. Moment Frame Systems

Standard connections of seismic design are prequalified in accordance with the AISC 358-2005 (Seismic Provisions for Structure Steel Buildings) for use special moment frame (SMF) and intermediate moment frame.

2.1 Special Moment Frame (SMF)

Special moment frames are expected to withstand significant inelastic deformations when subjected to the forces resulting from the motions of the design earthquake. Design SMF system shall satisfy, the requirement and limitations shall be accordance in AISC 341(2005), Section 9.

2.2 Intermediate Moment Frame (IMF)

Intermediate moment frames are expected to withstand limited inelastic deformations in their members and connections when subjected to the forces resulting from the motions of the design earthquake. Design SMF system shall satisfy, the requirement and limitations shall be accordance in AISC 341 (2005), Section 10.

3. Reduced Beam Section (RBS)

In AISC 358 (2005), Section 5; RBS shall qualification requirements and limits conditions of beam section.

- 1) Beam Limitations

Beam shall satisfy the following limitations:

- Beams shall be rolled wide-flange or built-up I-shaped members conforming to the requirements of Section 2.3.
- Beam depth is limited to W36 (W920) for rolled shapes. Depth of built-up sections shall not exceed the depth permitted for rolled wide-flange shapes.
- Beam weight is limited to 300 lbs/ft (447 kg/m).
- Beam flange thickness is limited to 13/4 in. (44.5 mm).
- The clear span-to-depth ratio of the beam shall be limited as follows:
(a) For SMF systems, 7 or greater.
(b) For IMF systems, 5 or greater.
- Width-thickness ratios for the flanges and web of the beam shall conform to the limits of the AISC 341 (Seismic Provisions).
- Lateral bracing of the beams shall be provided as follow AISC 341, section 9.8 for SMF and section 10.8 for IMF.
- The protected zone consists of the portion of beam between the face of the column and the end of the reduced beam section cut farthest from the face of the column.

2) Column Limitations

Columns shall satisfy the following limitations:

- Columns shall be any of the rolled shapes or built-up sections permitted in Section 2.3.
- The beam shall be connected to the flange of the column.
- Rolled shape column depth shall be limited to W36 (W920). The depth of built-up wide-flange columns shall not exceed that for rolled shapes. Flanged cruciform columns shall not have a width or depth greater than the depth allowed for rolled shapes. Built-up box

columns shall not have a width or depth exceeding 24 in. (610 mm). Boxed wide-flange columns shall not have a width or depth exceeding 24 in. (610 mm) if participating in ortho-gonal moment frames.

- There is no limit on the weight per foot of columns.
- There are no additional requirements for flange thickness.
- Width-thickness ratios for the flanges and web of columns shall conform to the limits in Table I-8-1 of the AISC Seismic Provisions.
- Lateral bracing of columns shall conform to Section 9.7 or 10.7 for SMF or IMF, as applicable, in the AISC 341 (Seismic Provisions).

3) Beam-Column Relationship Limitations

Beam-column connection shall satisfy the following limitations to the requirement in AISC 341 (Seismic Provisions), section 9.3 for SMF and section 10.3 for IMF.

4) Beam Flange to Column Flange Weld Limitations.

Beam flange to column flange connections shall satisfy the following limitations:

- (a) Beam flanges shall be connected to column flanges using complete joint penetration (CJP) groove welds. Beam flange welds shall conform to the requirements for demand critical welds in Section 7.3 and Appendix W of the AISC Seismic Provisions.
- (b) Weld access hole geometry shall conform to the requirements of the AISC Specification Section J1.6.

5) Beam Web to Column Connection Limitations

The required shear strength of the beam web connection shall be determined

according to Equation 5.8-9 (AISC358 - 2005). For web connection detailing, SMF system shall be connected the column flange using a CJP groove weld extending between weld access hole. And IMF system, the beam web shall

be connected to the column flange per as required for SMF systems.

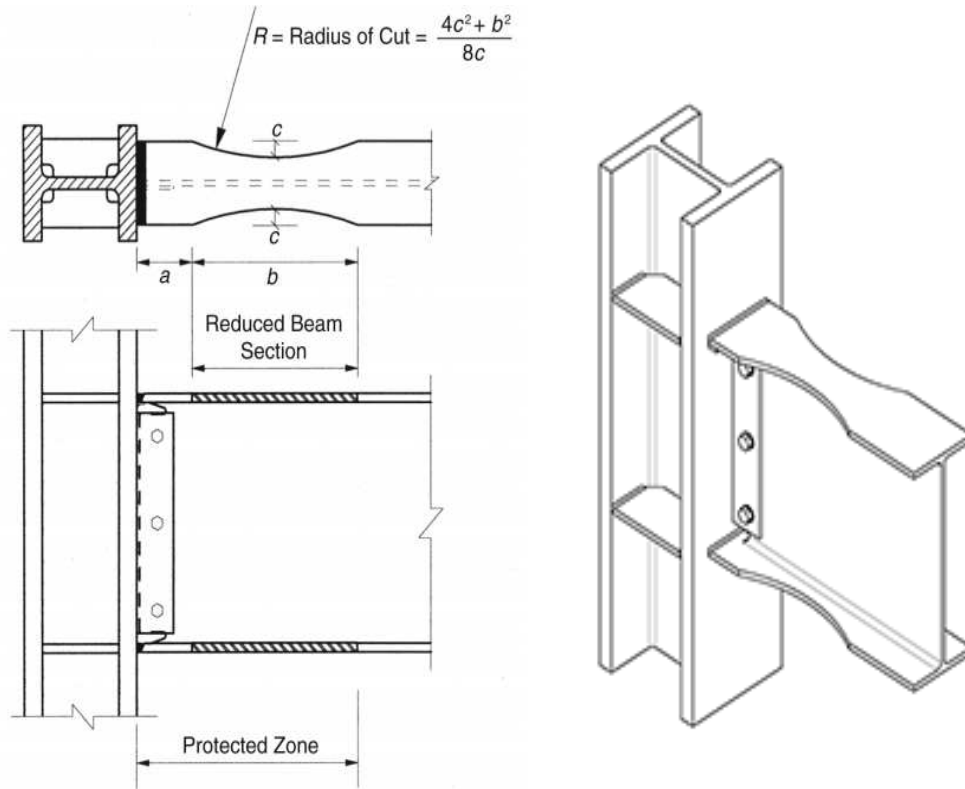

Figure 1. Reduced Beam Section (RBS)



Figure 2. Application of Reduced Beam Section (RBS) Connection

4. Analysis and Modeling Reduced Beam Section

The analysis of RBS to modeling with finite element method make use of SAP2000. Dimension of structure element model has been calculated in accordance with requirement and

limitations for reduced beam section connection.

- Beam : IWF 400X200X8X13
- Column : IWF 450X200X9X14
- Steel Grade: ASTM A992
- Beam-column connection assumed use a complete joint penetration (CJP) weld.

- Horizontal distance between a col-umn flange and the start of an RBS cut (a), 100mm
 - Length of an RBS cut(b), 450mm
 - Depth of cut at the center of the reduced beam section, 45mm
 - Thickness of Continuity Plate, 24mm
- (45% reduction in the flange of beam area)

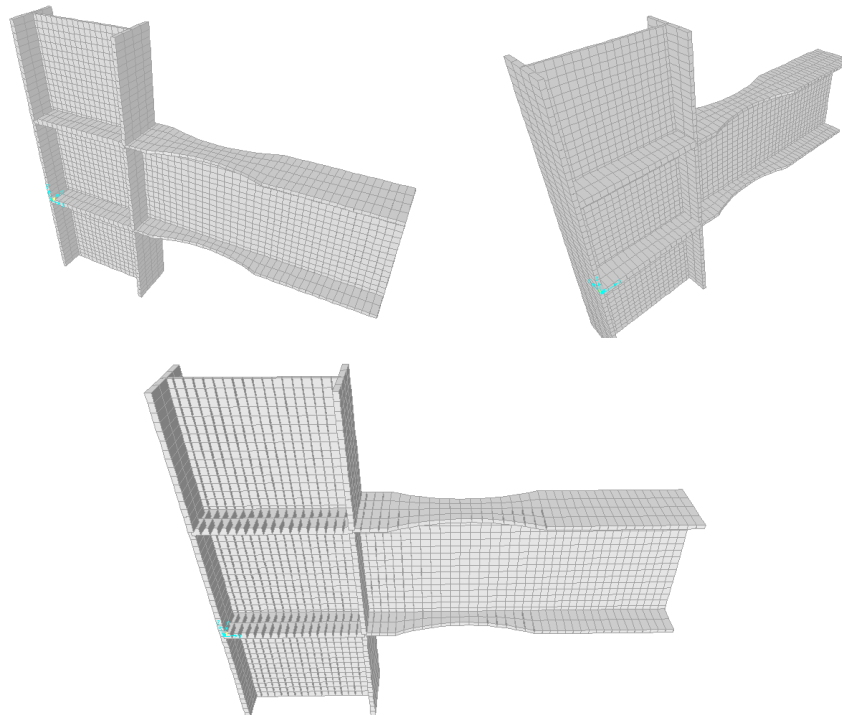

Figure 3. Modeling Reduced Beam Section

PREQUALIFICATION LIMITS

Beam : IWF400X200

$d_b := 400\text{mm}$	$w_b := 66 \frac{\text{kg}}{\text{m}}$
$b_{bf} := 200\text{mm}$	$Z_{xb} := 1190\text{cm}^3$
$t_{bf} := 13\text{mm}$	$r_{by} := 16\text{mm}$
$t_{bw} := 8\text{mm}$	$I_{by} := 1740\text{cm}^4$

Column IWF500X200

$$d_c := 500\text{mm}$$

$$Z_{xc} := 1910\text{cm}^3$$

$$b_{cf} := 200\text{mm}$$

$$A_g := 114.2\text{cm}^2$$

$$t_{cf} := 16\text{mm}$$

$$r_y := 20\text{mm}$$

$$t_{cw} := 10\text{mm}$$

Material Type of Steel :

ASTMA992

$$E_s := 200000\text{MPa}$$

$$F_y := 344\text{MPa}$$

$$F_u := 448\text{MPa}$$

$$R_y := 1.1$$

Ratio of the expected yield stress to the specified minimum yield stress F_y as specified in the AISC Seismic Provisions (AISC 341[2016], Tabel A3.1)

Seismic Design: Structure Steel Intermediate Moment Frame

Determine plastic section modulus at the reduced beam section :

$$0.5 \cdot b_{bf} = 100 \cdot \text{mm} \quad 0.75 \cdot b_{bf} = 150 \cdot \text{mm}$$

$$0.65 \cdot d_b = 260 \cdot \text{mm} \quad 0.85 \cdot d_b = 340 \cdot \text{mm}$$

$$0.1 \cdot b_{bf} = 20 \cdot \text{mm} \quad 0.25 \cdot b_{bf} = 50 \cdot \text{mm}$$

Digunakan :

$$a := 100\text{mm}$$

$$b := 450\text{mm}$$

$$c := 45\% \cdot \left(\frac{b_{bf}}{2} \right) = 45 \cdot \text{mm} \quad 45\% \text{ reduction in the flange of beam area}$$

$$\text{Check_RBS} := \begin{cases} \text{"OK"} & \text{if} \\ \left. \begin{array}{l} 0.5 \cdot b_{bf} \leq a \leq 0.75 \cdot b_{bf} \\ 0.65 \cdot d_b \leq b \leq 0.85 \cdot d_b \\ 0.1b_{bf} \leq c \leq 0.25 \cdot b_{bf} \end{array} \right\} & \text{AISC 358 (2005), Section 5.8} \\ \text{"NOT OK"} & \text{otherwise} \end{cases}$$

$$\text{Check_RBS} = \text{"OK"}$$

Determine the radius of the flange cut:

$$R := \frac{4c^2 + b^2}{8c} \quad R = 585 \cdot \text{mm}$$

Determine distance to Reduced Beam Section

$$S_h := \frac{d_c}{2} + a + \frac{b}{2} \quad S_h = 575 \cdot \text{mm}$$

Determine

$$L_{\text{ww}} := 6000 \text{mm}$$

$$L_1 := L - 2 \cdot S_h \quad L_1 = 4850 \cdot \text{mm}$$

Beam Limitations

AISC 358 (2005), 5.3.1

Check depth of beam

$$d_b = 400 \cdot \text{mm}$$

$$\text{Check}_{db} := \begin{cases} \text{"OK"} & \text{if } d_b \leq 960 \text{mm} \\ \text{"NOT OK"} & \text{otherwise} \end{cases}$$

$$\text{Check}_{db} = \text{"OK"}$$

Check weight of beam

$$w_b = 66 \cdot \frac{\text{kg}}{\text{m}}$$

$$\text{Check}_{wb} := \begin{cases} \text{"OK"} & \text{if } w_b \leq 447 \frac{\text{kg}}{\text{m}} \\ \text{"NOT OK"} & \text{otherwise} \end{cases}$$

$$\text{Check}_{wb} = \text{"OK"}$$

Check thickness of the beam flange

$$t_{bf} = 13 \cdot \text{mm}$$

$$\text{Check}_{t,bf} := \begin{cases} \text{"OK"} & \text{if } t_{bf} \leq 44.5 \text{mm} \\ \text{"NOT OK"} & \text{otherwise} \end{cases}$$

$$\text{Check}_{t,bf} = \text{"OK"}$$

The clear span to depth ratio of the beam

$$L_{\text{ww}} := 6 \text{m}$$

$$\text{Ratio} := \frac{L}{d_b} = 15$$

$$\text{for IMF: } \text{Check}_{\text{rasio.db}} := \begin{cases} \text{"OK"} & \text{if } \text{Ratio} \geq 5 \\ \text{"NOT OK"} & \text{otherwise} \end{cases}$$

$$\text{Check}_{\text{rasio.db}} = \text{"OK"}$$

Width-thickness ratios for the flanges and web of the beam

Flange:

$$\frac{b_{bf} - 2c}{2t_{bf}} = 4.231 \qquad 0.3 \cdot \sqrt{\frac{E_s}{F_y}} = 7.234$$

$$\text{Flange_beam} := \begin{cases} \text{"OK"} & \text{if } \frac{b_{bf} - 2c}{2t_{bf}} \leq 0.3 \cdot \sqrt{\frac{E_s}{F_y}} \\ \text{"NOT OK"} & \text{otherwise} \end{cases}$$

Flange_beam = "OK"

Web:

$$\frac{d_b}{t_{bw}} = 50 \qquad 0.3 \cdot \sqrt{\frac{E_s}{F_y}} = 7.234$$

$$\text{Web_beam} := \begin{cases} \text{"OK"} & \text{if } \frac{d_b}{t_{bw}} \leq 2.45 \cdot \sqrt{\frac{E_s}{F_y}} \\ \text{"NOT OK"} & \text{otherwise} \end{cases}$$

Web_beam = "OK"

5. Result and Discussion

5.1 Analysis Results of Modeling

Modeling of reduced beam section connection that static load applied on beam WF400X200 and col-

umn WF450X200, with finite element method use SAP2000 obtain the result of normal stress and shear stress as in Figure 4:

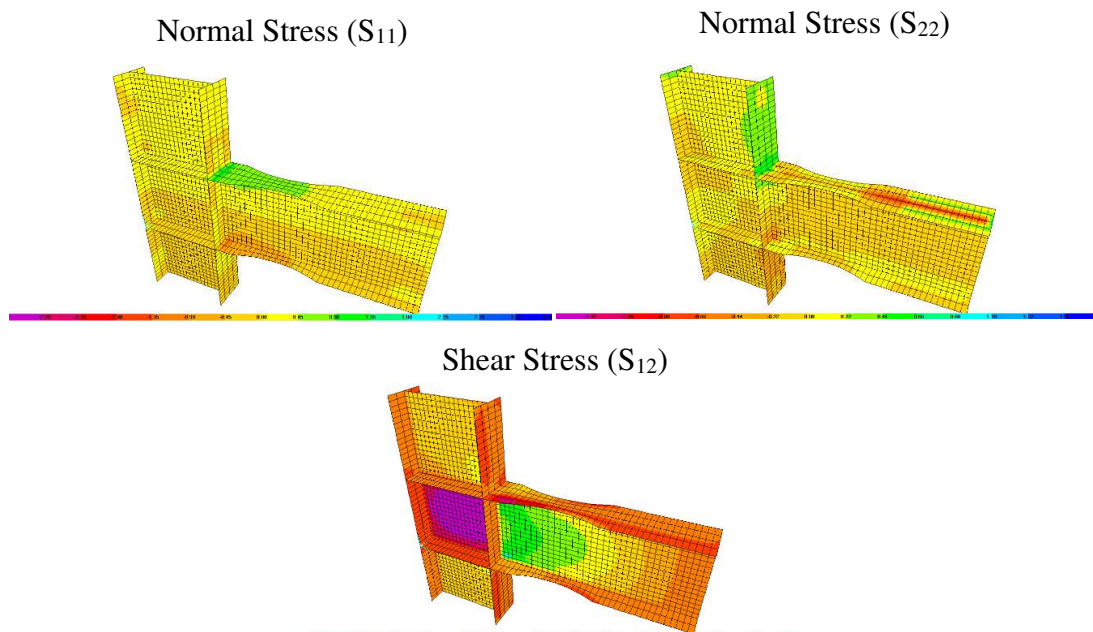

Figure 4. Show Stress Analysis

5.2 Stress Analysis

a) Normal Stress of Beam

The normal stress that occur on the beam flange is largest than the beam web, while the normal stress on the face of the column is smaller (Figure 5). The top of the beam occur maximum tensile

strenght 1367 kN/m², the bottom of the beam has a compressive stress 2943 kN/m² and the beam web has a tensile stress 1281 kN/m². While the normal stress on the face of the column occur tensile stress 667 kN/m² and the column web 857 kN/m².

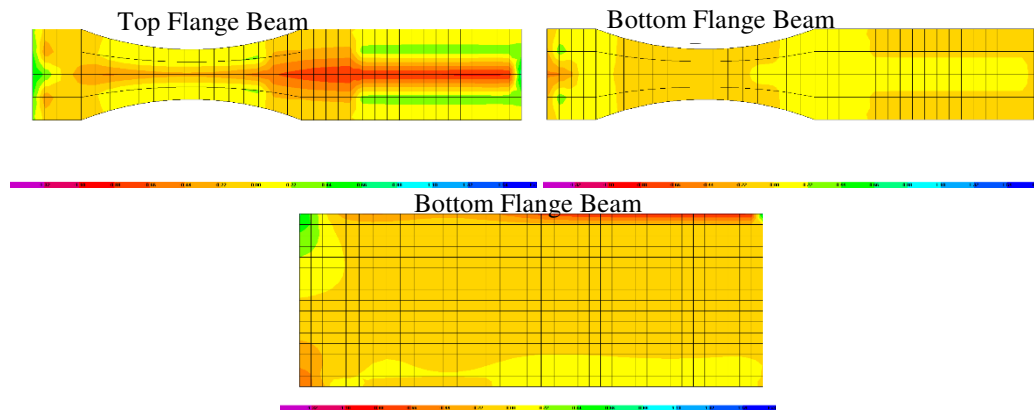

Figure 5. Show The Normal Stress flange and web of beam

b) Shear Stress of Beam- Column

The shear stress in the beam web is largest (857 kN/m²) than on the beam flange (275 kN/m²). While

the shear stress on the column is smaller (503 kN/m²) than the beam of the shear stress. Figure 6.

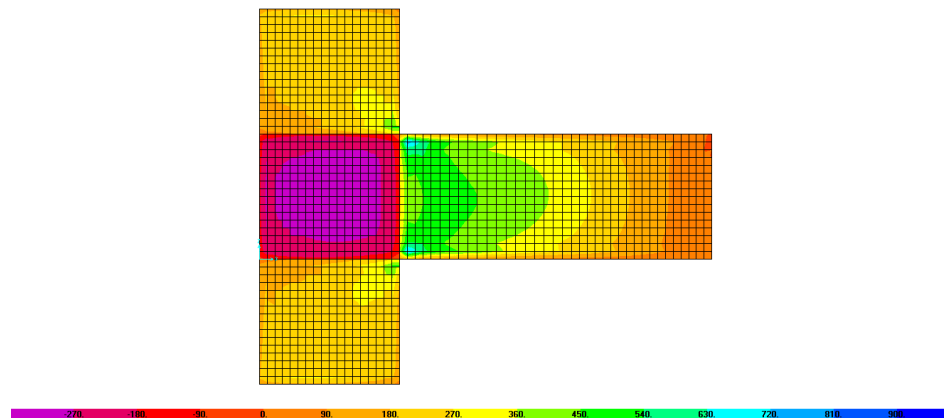

Figure 6. Show Stress S₁₂ Side View

6. CONCLUSION

The results of this study are summarized as follows.

- 1) The result of analysis finite element method using SAP2000 obtained the largest stress concentration is in the area of reduced beam section area, that

allows of plastic hinge in the area of RBS.

- 2) The maximum shear stress on the beam web may result involve local buckling condition. But the the shear stress of the column is smaller than the beam stress.
- 3) Make use of reduced beam section connection in steel

structure building with special moment frame system allows occur the collapse mechanism of global or (strong column weak beam), but shall be accord to requirement.

7. REFERENCES

- ANSI/AISC 341-05. *Seismic Provisions for Structural Steel Buildings*. American Institute of Steel Construction. Chicago. Illinois.
- ANSI/AISC 358-05. *Prequalified Connection For Special And Intermediate Steel Moment Frame For Seismic Application*. American Institute of Steel Construction. Chicago. Illinois.
- Chi, B. and Uang, C.-M. 2002. *Cyclic Response and Design Recommendations of Reduced Beam Section Moment Connections with Deep Column*. J. Struct. Engrg., ASCE, 128(4), 464-473
- Iwankiw, N. 1997. *Ultimate strength consideration for seismic design of the reduced beam section (internal plastic hinge)*. Engrg. J. 34(1), 3-16
- Kevin S. Moore., Joyce Y. Feng. 2007. *Design of RBS Connection for Special Moment Frame*. Oak-land. California.
- Suradjin S. 2012. *Penampang Balok Tereduksi (Reduced Beam Section) Dalam Peraturan Baja Struktural Indonesia Untuk Gedung Sni 1729-20xx*. KoNTekS 6. Jakarta

Author Biography:

Kukuh Kurniawan Dwi Sungkono, Undergraduates Program of Civil Engineering Semarang State University (2008), Graduate Program of Civil Engineering Gadjah Mada University (2010). Lecturer at Program of Civil Engineering, Engineering Department Tunas Pembangunan University of Surakarta.