

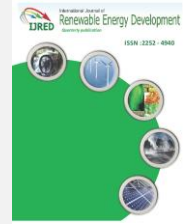

Contents list available at IJRED website

Int. Journal of Renewable Energy Development (IJRED)

Journal homepage: <http://ejournal.undip.ac.id/index.php/ijred>



Performance and Feasibility Analysis of a Grid Interactive Large Scale Wind/PV Hybrid System based on Smart Grid Methodology Case Study South Part – Jordan

Qais H. Alsafasfeh* ¹

¹ Tafila Technical University, Engineering Faculty, Power and Mechatronics Engineering Department, Tafila, Jordan,

ABSTRACT: Most recent research on renewable energy resources main one goal to make Jordan less dependent on imported energy with locally developed and produced solar power, this paper discussed the efficient system of Wind/ PV Hybrid System to be than main power sources for south part of Jordan, the proposed hybrid system design based on Smart Grid Methodology, the solar energy will be installed on top roof of electricity subscribers across the Governorate of Maan, Tafila, Karak and Aqaba and the wind energy will set in one site by this way the capital cost for project will be reduced also the simulation result show the feasibility is a very competitive and feasible cost. Economics analysis of a proposed renewable energy system was made using HOMER simulation and evaluation was completed with the cost per kilowatt of EDCO company, the net present cost is \$2,551,676,416, the cost of energy is 0.07kWhr with a renewable fraction of 86.6 %.

Keywords: HOMER, Renewable energy sources, hybrid system, PV, Wind & Economic Viability.

Article History : Received November 1,2014; Received in revised form January 2,2015; Accepted February 11, 2015; Available online

How to Cite This Article: Alsafasfeh, Q.H. (2015). Performance and Feasibility Analysis of a Grid Interactive Large Scale Wind/PV Hybrid System based on Smart Grid Methodology Case Study South Part – Jordan. *Int. Journal of Renewable Energy Development*, 4(1), 39-47. <http://dx.doi.org/10.14710/ijred.4.1.39-47>

1. Introduction

Growing interest in renewable energy resources during the last decades because of the continues energy demand increasing parallel with fossil fuel resources decreases, additional to the environmental effect to the earth (Clean Energy Pipe Line,(2014)). These facts make these energy resources attractive for many applications, with the accessibility of numerous forms of clean energy sources such as solar and wind technologies which are commonly used and more appropriate for many geographical locations, Jordan is a net importer of energy, importing 96% of its total energy consumption according to government statistics. Over 80% of energy is imported via the Arab Gas Pipeline (AGP), which transports natural gas from Egypt to Jordan, also Jordan is subject to market and political factors, making solar energy an attractive option (Clean Energy Pipe Line,(2014)).

Hybrid is means the mixture of two or more energy resources. So, The Hybrid (Solar-Wind Energy) power

system associations the energy from the sun and the Wind, making it the best system for sustainable energy supply, the concept of hybrid power system operating on wind and solar is not well-known yet all over the world and it is still considered as a new technology but new researchers started working on it such as in Ahmed, Ran & Bumby (2008) here a mathematical simulation for the system was modeled and analyzed using many control approaches. Proposed system does not used for AC/DC load as it is directly linked to the utility Jain, Yanbo & Lihua (2011) summarizes and presents the benefits and difficulties of the construction of a standalone hybrid power system. While various operation ways and control schemes are analyzed in this paper, no specific simulation model for both of them is produced, Chedid & Rahman (2012) engaged a linear programming method for sizing optimally hybrid system with lowest average production cost of electricity also the load level meet at suitable level, a micro grid control of PV-Wind-Diesel hybrid system

* Corresponding author : qsafasfeh@ttu.edu.jo

with islanded and grid connected operations is discussed in Arulampala, Mithulananthan, Bansal & Saha (2010), also Shun & Ahmed (2008) designed a low-cost hybrid ventilation device that utilizes both wind and solar energy as power sources, another application Vick, Clark, Ling & Ling (2003) used arrangement of wind and solar energy effectively to power an ultraviolet water purification system. In recent years many researcher apply hybrid system in many countries such as Bangladesh an optimization of a wind-photovoltaic-battery hybrid system was used by Nandi & Ghosh (2009), also Nigeria by Somkene, Mbakwe, Iqbal & Hsiao (2012), Algeria by Saheb-Koussa, Haddadi, & Belhamel (2009), and Iraq by Salwan, Dihrab & Sopian (2010).

Most of studies used Hybrid Optimization Model for Electric Renewable (HOMER), a feasibility study of photovoltaic, Wind and Diesel hybrid system is presented by Rahman, Alam & Al-Hadhrami (2012). In this research optimal sizing of the hybrid system components and economic analysis is performed based on the software also Bhuiyan, Deb & Nasir (2013), model has been modified to find out the best technically feasible renewable based energy efficient system for household.

Resents research on renewable energies based on hybrid system with wind and solar has been made in Jordan by El-Tous, Al-Battat & Abdel-Hafith (2013) an examination of hybrid system at Tafila governorate in Jordan, and energy economics are examined, the system structure is simulated using HOMER and Al-Masri & Amoura (2012) investigates the feasibility of a grid connected, large-scale hybrid wind/PV system at Ras El-naqab in Jordan MATLAB and HOMER software's are used for sizing and economical analysis respectively. This paper will present the efficient system of Wind / PV Hybrid System to be than main power sources for south part of Jordan, the proposed hybrid system design based on Smart Grid Methodology, the solar energy will be installed on top roof of electricity subscribers across the Governorate of Ma'an, Tafila, Karak and Aqaba and the wind energy will set in one site by this way the capital cost for project will be reduced also the simulation result based on HOMER software show the feasibility is a very competitive and feasible cost.

2. Smart grid Methodology

Integration of smart grid gives many advantages concerning operation security, integration of renewable energy as well as energy trading. To decreases the capital cost for project, the solar energy will installed on top roof of electricity subscribers across the Governorate of Maan, Tafila, Karak and Aqaba and the wind energy will set in one site as mentioned above, the proposed smart grid as shown in Figure 1, the smart grid will proposed based on Petra solar smart grid

model each solar panel contains the following components

- AC Solar Module: Smart Energy Module (SEM™) integrated with the AC Module to provide energy generation, monitoring, command and control
- Communicator: Access Point connecting several hundred geographically dispersed AC Modules to the backend system.
- Intelligent operation center (Network Management): Monitoring, command and control of the systems by Haddad, Amarin, El-Nimri & Kuran (2013).

3. Site location

3.1 Renewable energy in Jordan

Jordan has great location, which have the best source for renewable energy resources like solar and wind. These factors aforementioned altogether will affect the Jordanian economy, and that's why the more evolved countries have taken serious steps in the field of renewable energy. In spite of Jordan hasn't taken any significant step toward renewable energy in the last decade, it began to look toward photovoltaic and wind energy fields lately, Jordan has an excellent level of solar irradiance as shown in the solar irradiance distribution atlas shown in Figure 2. As it can be seen from the Figure 2 the areas with highest solar irradiance are located in the center and south, but the overall energy is very high reaching values as high as 2330 kWh/m²/year.

3.2 Solar Energy project site

Without any doubt the most important factor in selecting the photovoltaic project site is the solar irradiance, as it directly affects the amount of energy generated from the panels. South part of Jordan was chosen for this project due to its high solar radiation. The higher the solar irradiance of the site the more feasible the project will become, and that's because the income generated from the energy sold will be higher.

The scope of the overall project is to deploy solar panels on the roofs of electricity subscribers across the Governorate of Ma'an, Tafila, Karak and Aqaba. The total number of consumers until the end of 2013 was 209637 EDCO, Annual Report (2013) as shown in Table 1 The average solar irradiance of south part is of 5.475 kWh/m²/ day which are considered so high and appropriate for photovoltaic energy plant projects, Figure 3 shows the typical day-to-day solar irradiance in kwh/m² for each month of the year (National center for research and development of Jordan, (2013))

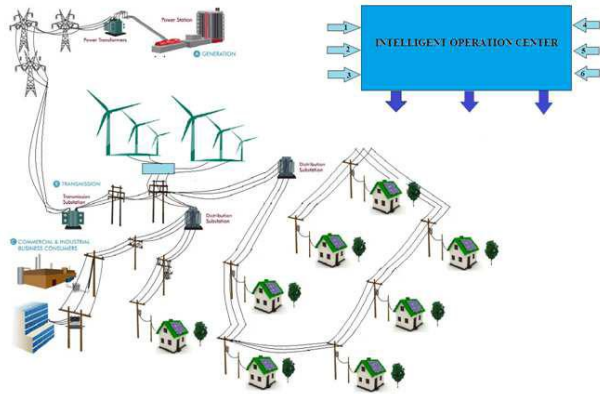

Fig. 1 Smart grid Methodology

Tabel 1

The total number of electricity subscribers

City	Single Phase	3 Phase	Total
Ma'an	27927	2303	30320
Tafila	20229	972	21201
Karak	60412	3478	63890
Aqaba	37871	6745	44616

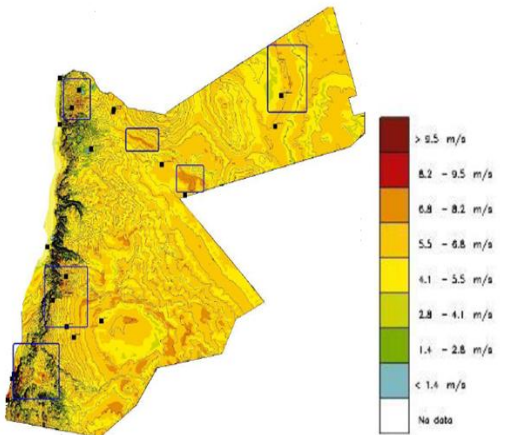
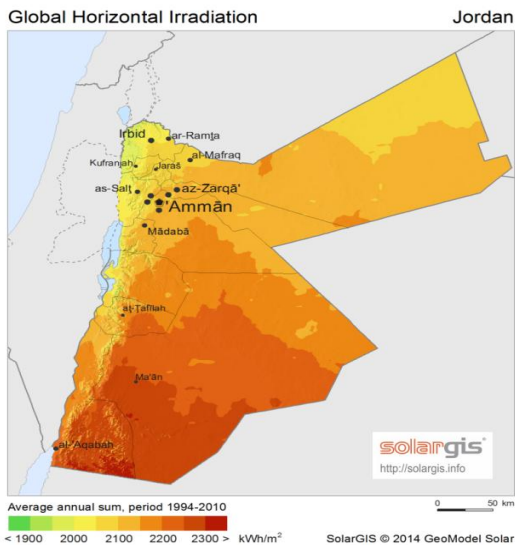

Fig. 2 Jordan solar irradiance& wind speed distribution.

3.3 Wind Energy Solar project site

Al Fujaij is a small village located in north of Ma'an city (far away from the center of Ma'an about 105 KM) with the coordinates E 35.62815°, N 30.54583° as shown in Figure 4, it covers an area of 65 km² relatively as it represents 17% of Ma'an total area. It has a population of (3500) including the military bases in that region.

Fujaij has following advantages: Fujaij contains a very large usable space that is not inhabited, and the costs are very low, which in turn decreases the total cost of the project also surface flatness is one of the most important aspects of the site selected for the photovoltaic project, mountainous terrain types are not suitable, surface flatness is required to decrease the costs associated in the land conditioning.

Figures 5 show that Fujaij has annual values of wind speed (7.26 m/s), this speed it is an appropriate and excellent choice for the proposed system

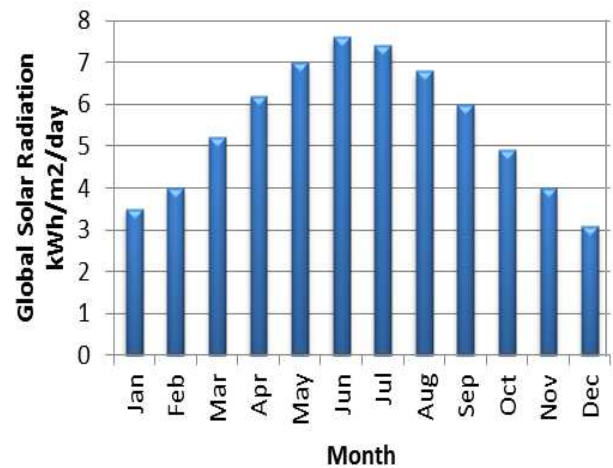

Fig.3 The average day-to-day solar radiation (Wh/m2. Day) at 2013

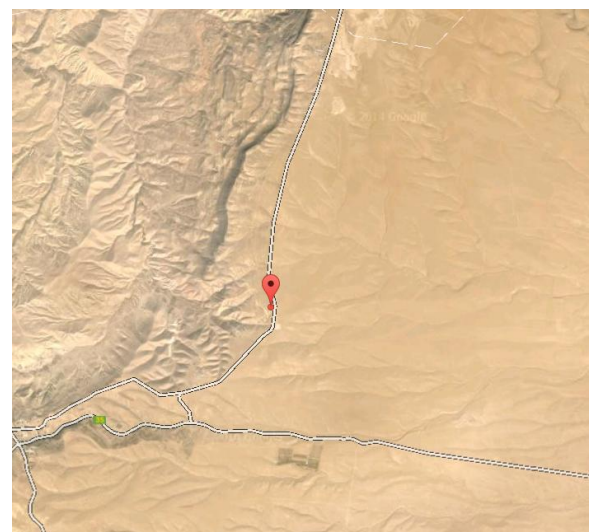

Fig.4 the Google map of Al- Fujaij

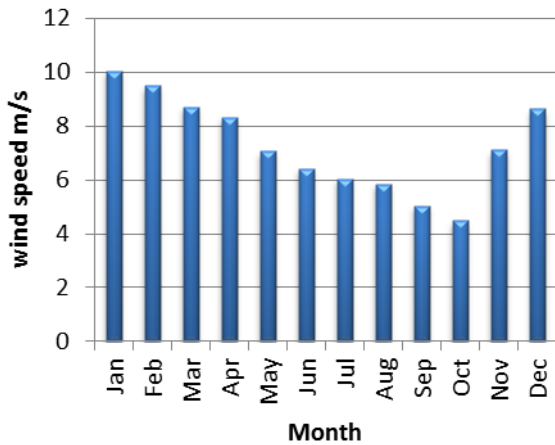

Fig5. Monthly average values of wind speed for the year 2013

4. The load calculation

The most important factor to start feasibility study is load profile. The load data for South Part of Jordan (Ma’an, Tafila, Karak and Aqab) was used in paper were obtained from EDCO but to validate this study we will use the load characteristics based on forecasting result at 2016 made by EDCO as shown in Table 2 and total monthly load profile shown in Figure 6. (EDCO, Load Forecasting technical report, (2014))

Tabel 2

Load data for South Part of Jordan 2016

City	Ma’an	Tafila	Karak	Aqaba	Total
Average (kWh/day)	854,794	339,726	1,336,986	2,465,753	4,997,259
Average(MW)	35.37	14.155	55.7	102.74	207.965
Peak (MW)	57.65	40.84	107.27	165.23	371
Load Factor	0.61	0.35	0.52	0.62	

5. Sizing of Hybrid components

The first step in the load sizing is the determination of the load demand that has to be supplied by the system, the load to be supplied is a constant 208 MW load and one third of the total load is to be supplied by the wind turbine system while the other two thirds by a photovoltaic plant.

After determining the load profile and the sharing ratios the wind speed data and the solar irradiation data of the site has to be considered. Here we will illustrate the procedure of finding the load sizing in steps.

Calculate the load energy demand:

- Load energy demand= 208 MW*24 = 4992 MWh
- Calculate the Wind-PV power sharing:
- Wind turbine energy= 2/3*load energy demand
- Wind turbine energy= 3328 MWh
- PV energy= 1/3*load energy demand
- PV energy= 1664 MWh

5.1 PV Sizing

The selected PV panel is from the model KC200GT which has the following characteristics as shown in Table 3 also Current-Voltage & Power-Voltage Curve shown Figure 7.

Table 3:

Characteristics of SUNTECH - 300 PV panel. SUNTECH,(2012)

Module Type	Power Rating (W_p)	I_{SC} (A)	V_{OC} (V)	I_{mp} (A)	V_{mp} (V)	Dimension (m ²)
SUNTECH - 300	300	8.33	44.8	7.95	35.2	1.94



Fig.6 . Total monthly load profile

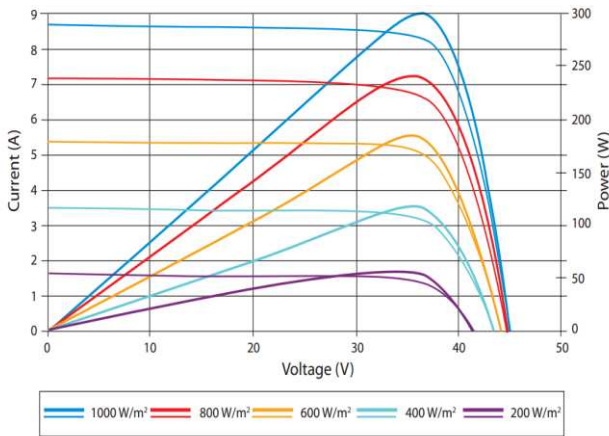

Fig 7. Current-Voltage & Power-Voltage Curve

From Figure 3 we can see that average solar radiation is approximately 5475 W/m² per day is equivalent to 10 peak sun hours and the maximum output of the panel is 300 Wp so:

- Daily PV energy= 10 hours*300W=3000 Wh
- Total num of panels = (PV energy share)/(Single pv panel daily energy)
- Number of panels will use = 1664 M/3000 ≈ 554667 panels

also the PV Component Costs shown in Table 4 which includes Capital, Replacement and Operation and maintenance for each panel

Table 4: PV system Component Costs, Hussein Al-Masri, FathiAmoura,(2012)

Component	Costs
Capital (\$)	1770
Replacement (\$)	0
Operation and maintenance for each panel \$/year	27

5.2 Wind Turbines Sizing

A similar approach is followed to calculate wind turbines sizing Table 5 shows the characteristics of the selected wind turbine Vestas V82

Table 5: Characteristics of the Vestas V82 turbine. VESTAS (2014)

Nominal Power (MW)	Nominal Wind Speed (m/s)	Rotor's Diameter (m)	Swept Area (m ²)	C _p
1.6	13	18	5,281	0.45

From Figure 5 we find that the average wind speed in the selected site is 7.25 m/s so the number of wind turbines required for the site:

- Daily wind turbine energy
- $$P = \frac{1}{2} \times \rho \times A \times V^3 \times C_p \quad (1)$$
- Where:
- C_p : Power Coefficient

- A : Swept Area
- P : Air Density
- V : Wind Speed

- Daily wind turbine energy =645649×24=15495.590 KWh
 - Total num of wind turbines = (Wind turbine system energy share)/ (Daily wind turbine energy production)
 - Total # of wind turbines = 3328M/15.5M =215
- Table (6) Parameters of the Wind turbine Cost components used for validation against HOMER

Table 6: Wind turbine Cost [14]

Component	Costs
Capital (\$)	2171400
Replacement (\$)	1500000
Operation and maintenance for each panel \$/year	50000

6. Feasibility Results and Analysis

The hybrid PV/wind power generation system has been used to power supply specific load requirements for a south part of Jordan. To set the feasibility study for hybrid system the main input data include; solar radiation, wind speed and load data; technical specifications and cost data of photovoltaic modules, wind turbines and converter as input to HOMER software, the single line diagram for hybrid system is shown in Figure 8,

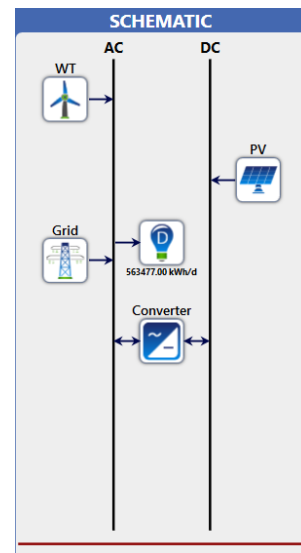

Fig.8 Single line diagrams based on HOMER software

The first important point of feasibility study is Cash Flow Summary which includes as shown in Table 7 capital, replacement and Operation and Maintenance cost (O&M) for each component and for project life of 25 years

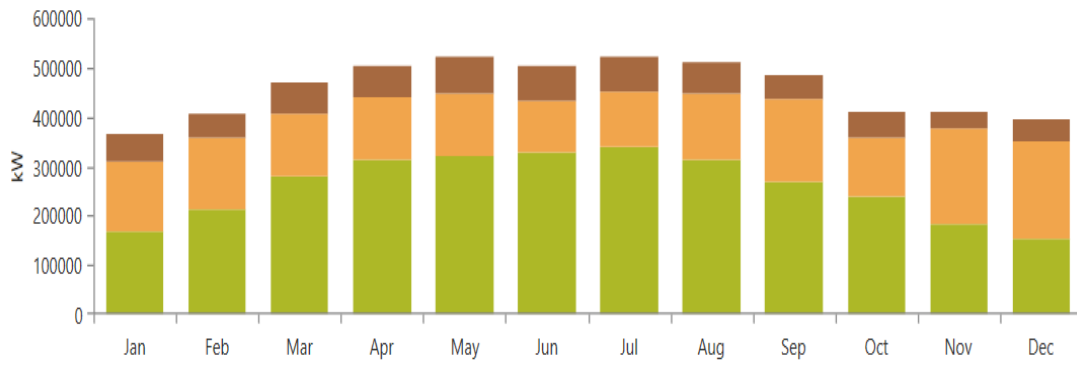

Fig.9 Monthly percentage electric production.

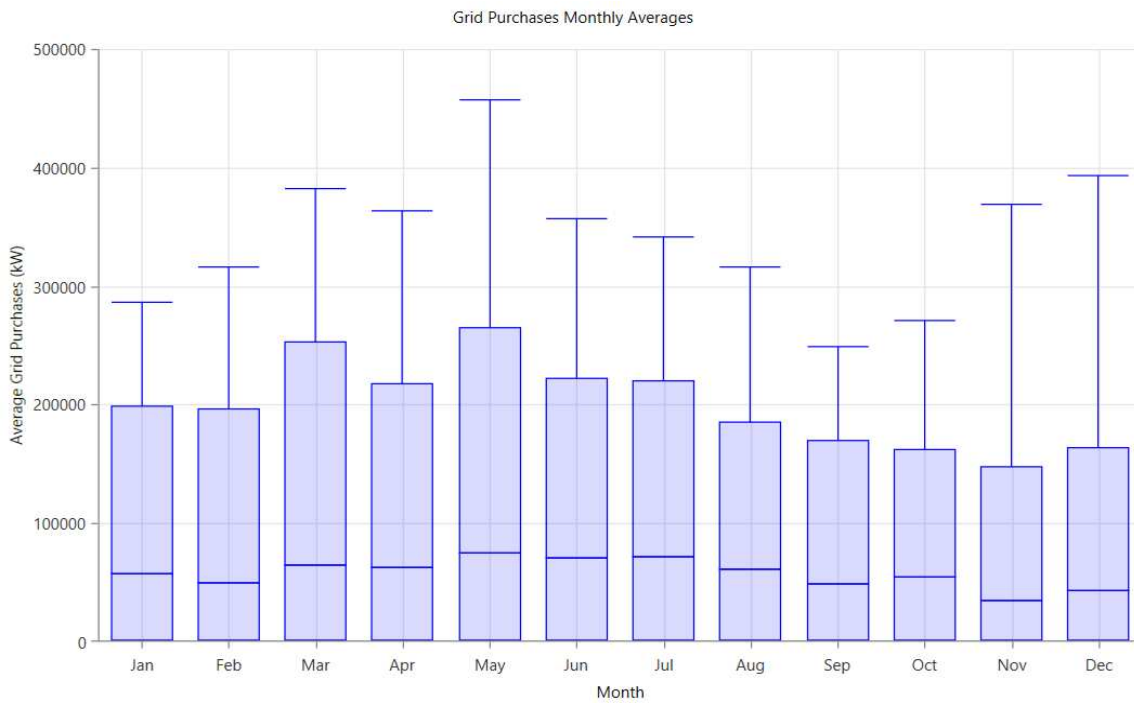

Fig.10 Grid Purchases Daily Profile

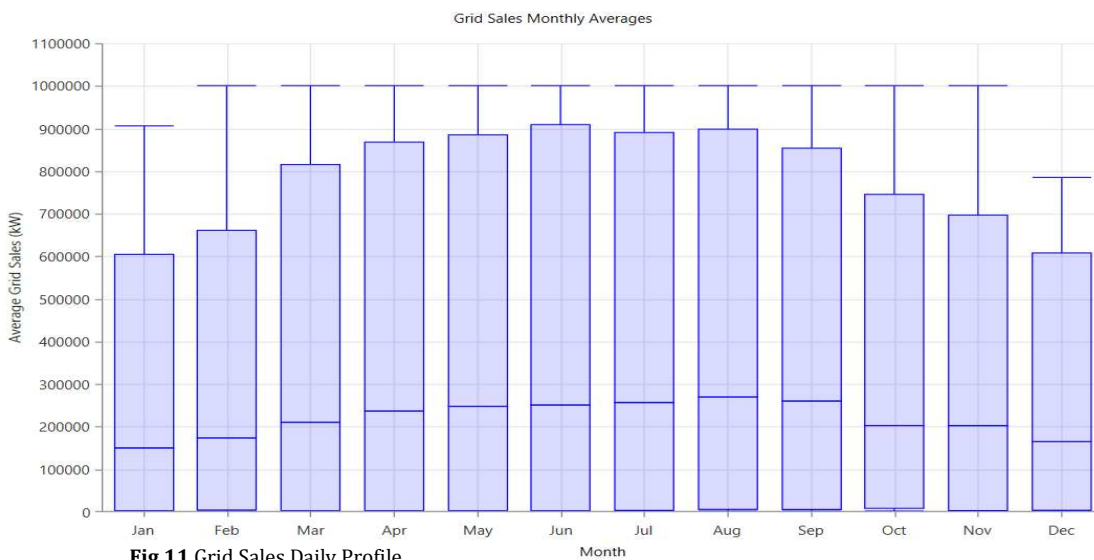

Fig.11 Grid Sales Daily Profile

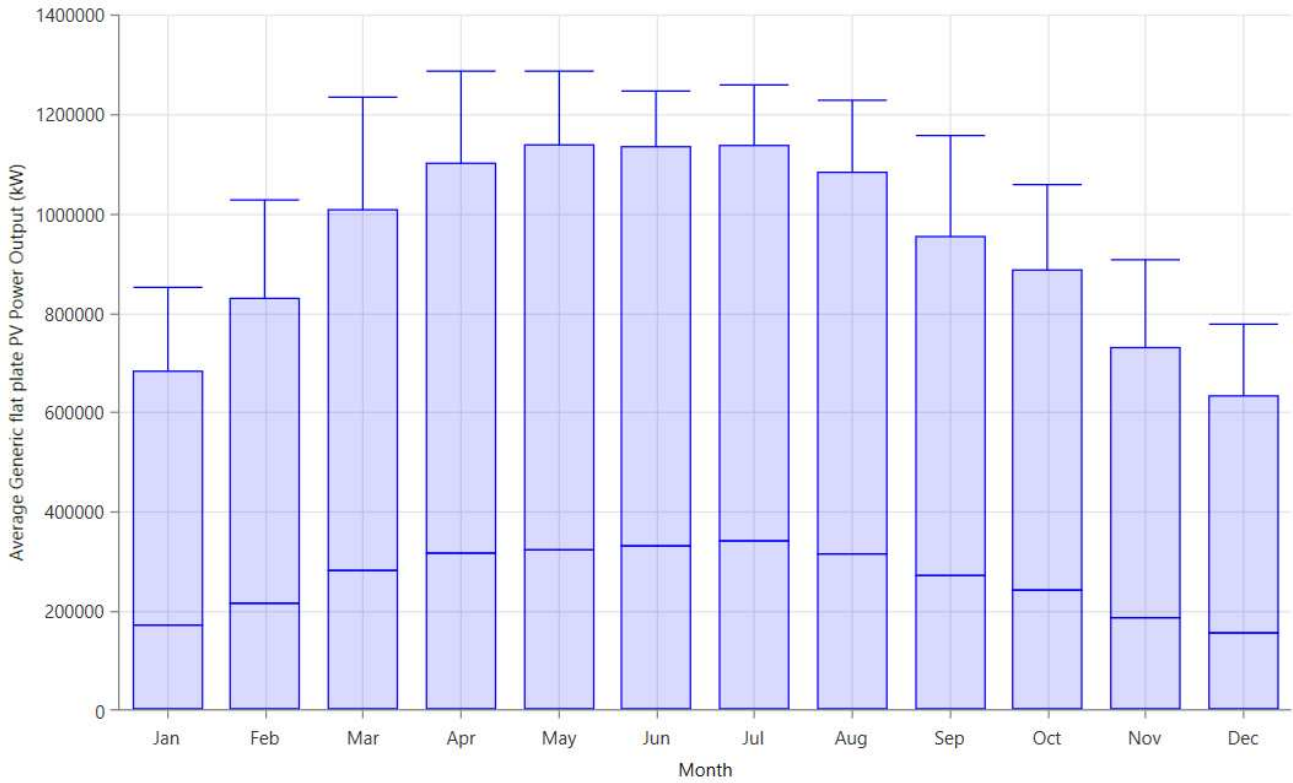

Fig.12 PV Power output Monthly average

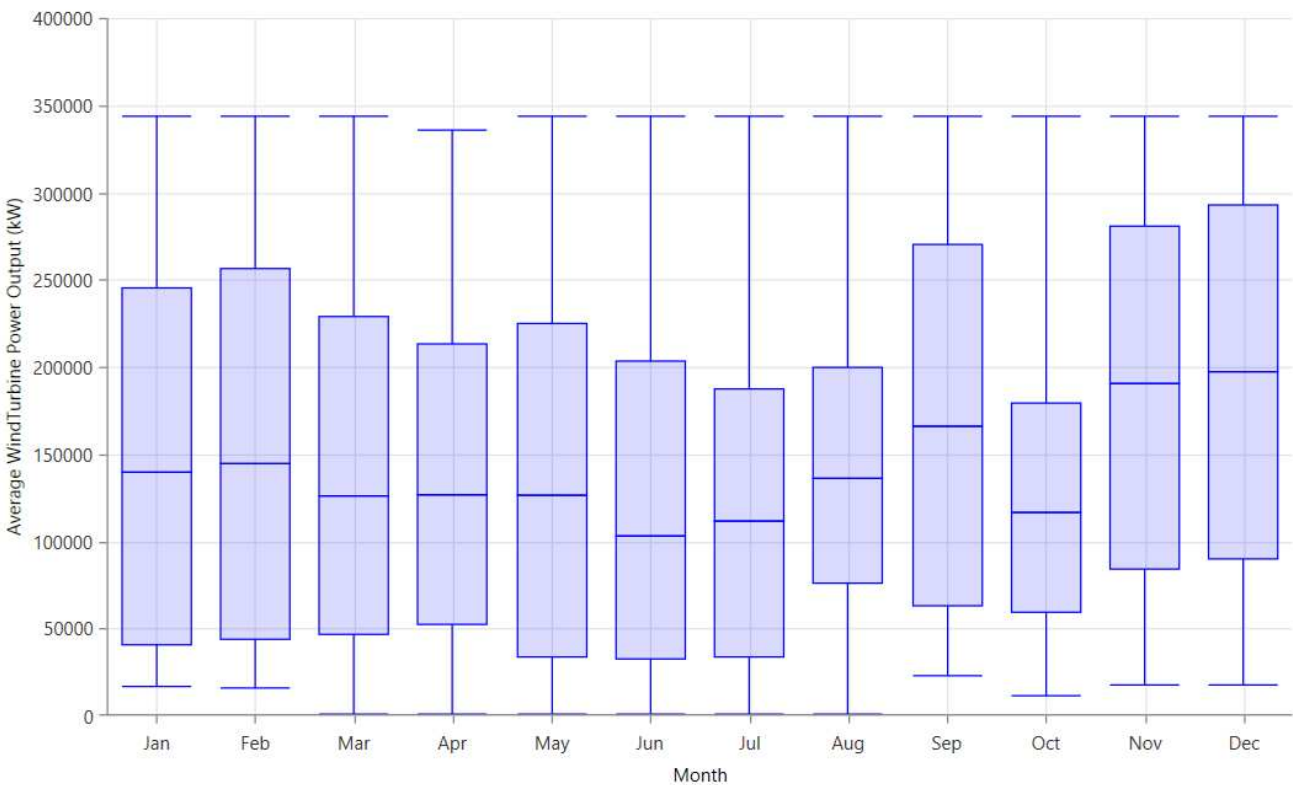

Fig.13 Wind Turbine Power output Monthly average

Table 7
 Cost summary by system component

Component	Capital(\$)	Replacement (\$)	O&M (\$)	Total (\$)
PV	\$1,946,880,000.0	\$0.00	\$441,308,768.00	\$2,388,188,416.0
Wind Turbine	\$466,851,008.00	\$0.00	\$105,592,688.00	\$572,443,776.00
Grid	\$0.00	\$0.00	-832,980,416.00	-832,980,416.00
Converter	\$407,680,000.00	\$0.00	\$16,344,768.00	\$424,024,704.00
System	\$2,821,411,072.0	\$0.00	\$269,734,080.00	\$2,551,676,416.0

The most important results regarding feasibility study is electrical analysis first of all we will discuss the cost of energy, the total cost of the hybrid project is \$2,551,676,928 then cost of energy (COE) is \$0.07 is an acceptable cost comparing with \$0.08 for current price, also the electrical simulation results which includes the annual production of electrical energy, the annual consumption of electrical energy and the annual excess, unmet load and renewable fraction the all result shown in Table 8.

Table 8:
 Electrical simulation results

Electrical Simulation Results		
Total net present cost	\$2,551,676,928	
Levelized cost of energy	0.07 \$/kWh	
Operating cost	27,460,624.0 \$/yr	
The annual production of electrical energy	kWh/ yr	%
PV	2,284,004,864	56.92
Wind turbines	1,229,171,200	30.63
Grid purchases	499,753,728	12.45
Total	4,012,929,792	100
The annual consumption of electrical energy	kWh/ yr	%
AC primary load	1,871,362,176	49.4
DC primary load	0	0.0
Grid sales	1,913,164,160	50.6
Total	3,784,526,336	100
The annual excess, unmet load and Renewable fraction	kWh/ yr	%
Excess electricity	5.3	0.0
Unmet electric load	0.8	0.0
Capacity shortage	0.0	0.0
Renewable fraction		86.8

Figure 9 shows monthly average electric production of the three sources of energy. It's readily seen from Figure 8 that the most part of the energy is supplied by the PV as planned June and July are the months which shows the highest PV produced. November and December are the month which shows the highest wind energy produced and the lowest PV energy which is related to the high wind speeds and low peak sun hours, Figure 10 and 11 present the purchasing & selling with grid for each month also Figure 12 present the output values of the photovoltaic array system, HOMER uses

the equation (2) to calculate the output of the PV array, HOMER assumes that the temperature coefficient of power is zero, under standard test conditions (kW), (Brihmat & Mekhtoub 2014),.

$$P_{PV} = Y_{PV} f_{PV} \left(\frac{\overline{G_T}}{G_{T,STC}} \right) \quad (2)$$

Where :

- Y_{PV} : Rated power output of the PV module
- f_{PV} ; is the PV derating factor (%)
- $G_{T,STC}$ Radiation at standard test conditions (kW/m²).

We note the PV output follow the solar radiation and the output values of the wind farm system was shown in Figure 13 the power was calculated in HOMER based on Equation (1).

7. Conclusion

In this paper, the performance analysis and feasibility study of Wind/ PV hybrid energy system under loading conditions is presented. A detailed modeling of both the PV and wind subsystem components are discussed and simulated in HOMER and the feasibility of the hybrid system over 25 years life time. The proposed hybrid system was designed based on Smart Grid Methodology, the solar energy will be installed on top roof of electricity subscribers across the Governorate of Maan, Tafila, Karak and Aqaba the total number of PV panels will be installed is 554667 and the wind energy will set in one site and the total number of wind turbine is 215. The total cost of the hybrid project is \$2,551,676,928 then cost of energy (COE) is \$0.07 is an acceptable cost

References

- An Analysis of Investment Opportunities in Jordan's Renewable Energy Sector," www.cleanenergypipeline.com. Accessed 27 October 2014.
- A. A. Ahmed, Li Ran, J. Bumby, (2008) Simulation and control of a hybrid PV Wind system", Power Electronics, Machines and Drives., PEMD, York, 2-4th April. 1-6.
- C. Jain, C. Yanbo, Z. Lihua, (2011), Design and research of off grid wind solar hybrid power generation systems", Power Electronics Systems and Applications, PESA ,1-5.
- Chedid R., Rahman S., (2012), Unit sizing and control of hybrid wind-solar power systems, IEEE Transactions on Energy Conversion, 12 , 79-85.
- A. Arulampalam, N. Mithulananthan, R. C. Bansal, T. K. Saha, (2010), Micro grid control of a PV-Wind-Diesel hybrid systems with islanded and grid connected operations", IEEE Sustainable Energy Technology, ICSET , 1-5
- Shun S., Ahmed N.,(2008), Utilizing wind and solar energy as power sources for a hybrid building ventilation device, Renewable Energy 33, 1392-1397.
- Vick B., Clark R., Ling J., Ling S.,(2003), Remote Solar-Wind and Hybrid Solar-Wind Energy Systems for Purifying Water, Journal of Solar Energy Engineering February 125 :107-111.

- Nandi S, Ghosh H., (2009), A wind-PV-battery hybrid power system at Sitakunda in Bangladesh, *Energy Policy* 37: 3659-3664.
- Somkene N. Mbakwe , M. T. Iqbal , and Amy Hsiao ,(2012), Design of a 1.5kW Hybrid Wind / Photovoltaic Power System for a Telecoms Base Station in Remote Location of Benin City, Nigeria”,
- D. Saheb-Koussa, M. Haddadi, M. Belhamel,(2009), Economic and technical study of a hybrid system (wind-photovoltaic-diesel) for rural electrification in Algeria, *Applied Energy* 86 : 1024 - 1030.
- Salwan S. Dhrab, K. Sopian, (2010), Electricity generation of hybrid PV/wind systems in Iraq, *Renewable Energy* 35: 1303-1307.
- S. Rahman, M. M. Alam, L. M. Al-Hadhrami, (2012), Feasibility study of a Wind-PV Diesel hybrid power system for a village”, *Renewable Energy*, February, 38, 1:258-268.
- Mahmud Abdul Matin Bhuiyan, Anik Deb, Arefin Nasir,(2013), Optimum Planning of Hybrid Energy System using HOMER for Rural Electrification”, *International Journal of Computer Applications*, 66, 13,45-52
- Yousif El-Tous, Saleh Al-Battat, Sandro Abdel Hafith,(2013), Hybrid wind-PV grid connected power station case study: Al Tafila, Jordan”. *International Journal of Energy and Environment*, 3,4: 605-616
- Hussein Al-Masri, FathiAmoura,(2012), Feasibility Study of a Grid Connected Hybrid Wind/PV System”, *International Journal of Applied Power Engineering*, 2, 2, 89 - 98
- Ghaith Haddad, Ruba Amarin, Salem El-Nimri and Mohammad Kuran,(2013), The Economic Impact of the 'Let Jordan Shine' Phase I Project in Tafila,” *The 8th Jordanian International Electrical & Electronics Engineering Conference*.
- EDCO, Annual Report, www.edco.com.jo Accessed 27 October 2014.
- National center for research and development of Jordan/ energy research program
- EDCO, Load Forecasting technical report, www.edco.com.jo, Accessed 27 October 2014.
- SUNTECH Solar Panel, 2012. <http://www.altestore.com/store/Solar-Panels/Suntech-STP300-24Vd-300W-24VSolar-Panel-USA/p7941/>. Accessed 25 Dec 2014
- VESTAS,http://www.vestas.com/Files/Filer/EN/Brochures/ProductBrochureV821_65_UK.pdf, Accessed 25 Dec 2014
- F. Brihmat, S. Mekhtoub, (2014), PV Cell Temperature/ PV Power Output Relationships Homer Methodology Calculation, *International Journal of Control, Energy and Electrical Engineering*, 2.