

Spatial Correlation of Radio Waves for Multi-Antenna Applications in Indoor Multipath Environments

Gamantyo Hendrantoro, Puji Handayani, Achmad Mauludiyanto

Jurusan Teknik Elektro, Institut Teknologi Sepuluh Nopember, Kampus ITS Sukolilo,
Surabaya 60111, Indonesia.

Email: {gamantyo, puji, maulud}@ee.its.ac.id.

ABSTRACT

This paper presents the results of a concerted effort in characterizing the spatial correlation of radio waves detected by a multi-element antenna system in indoor environments. The number of arriving paths and their directions are first studied through a series of measurements. The results are then used in a simulation to obtain spatial correlation indoors. It is found that generally an antenna array positioned near the center of the room will experience more rapidly decreasing correlation with spacing, which is a desired trait. In addition, a linear array oriented perpendicular to the length of the room in general shows better characteristics in terms of faster slope of correlation compared to the one in parallel with the length of the room. The average correlation indoors is also found to be similar to the correlation function arising from the two-dimensional circularly distributed random scatterers proposed by Clarke. For practical implementation of antenna arrays in small terminals for indoor wireless applications, it is suggested that the inter-element spacing be made 0.3λ in the least.

Keywords: antenna array, indoor radio channel

INTRODUCTION

Signal quality and channel capacity are among the most essential indicators of performance of wireless communication systems. Various attempts have been made in finding methods to maximize them simultaneously. Implementation of multi-antenna systems, either at the receiver or at the transmitter or both, is one of such efforts that have so far exhibited great improvements on the two indicators [1][2]. While providing space diversity leads to improvement of error rate performance in fading channels, multi-antenna systems can also render multiple channels with some degree of mutual orthogonality, which when used with spatial multiplexing scheme will considerably increase the spectral efficiency of radio channels [3][4]. Also, adaptive array antennas under the name of smart antennas have long been used in co-channel interference cancellation in multi-user wireless systems [5]. Achievement of the above strictly requires fulfillment of some constraints for the radio propagation channel. In particular, space diversity, spatial multiplexing, and smart antenna systems will work only when the signals on different antenna elements are uncorrelated [1][3]. Determination of spatial correlation of radio waves has accordingly played an important role in assessment of the effectiveness of multi-antenna systems. This is true in various types of propagation environments, including both outdoor and indoor contexts.

For outdoor cellular systems, Clarke [6] has proposed a very well-established physical model of scatterers in which they are lined up randomly along a circumference of a circle centered at the subscriber terminal. With this model in mind, spatial autocorrelation (or temporal if mobile users are considered) of radio waves can be derived in the form of Bessel function of the first kind of zeroth order, with a ratio of distance and wavelength being the argument. A circularly located scatterers model for outdoor environments might be quite reasonable, but it does not necessarily apply indoors. Inside a room, apart from the existence of surrounding walls, floor, and ceiling, there are also randomly scattered objects that can act as reflectors and scatterers. This is especially true in such rooms as offices, meeting rooms, labs, classrooms, libraries, and factories [5][7].

Many papers have simply stated that the abundance of scatterers in a room guarantees the low correlation of signals on antenna elements, but they have never gone into further detail on the form of the autocorrelation as a function of antenna separation. This paper reports an effort in characterizing spatial correlation of radio waves indoors in more details, with the final aim of determining a strategy to optimize receive antenna array orientation and location so as to obtain adequately uncorrelated signals on the elements. Rooms under study are assumed to be those with rectangularly-shaped horizontal layout. Thus, each of them is surrounded by four perpendicular walls of various dimensions. Both transmit and receive antennas are indoors, but they can be in separate rooms. Results are given in the form of spatial autocorrelation function of signal baseband envelope.

Note: Discussion is expected before June, 1st 2007. The proper discussion will be published in Electrical Engineering Journal volume 7, number 2, September 2007.

lopes, i.e. autocorrelation with respect to horizontal separation distance in space between two points. Aside from that, our contribution also includes recommendations on spatial orientation of the array elements with respect to the orientation of the room. The reported study is organized as follows. Firstly, a measurement campaign is conducted to obtain empirical statistics of direction of arrival (DoA) of radio waves indoors, which include statistics of number of arriving rays and angular spread. The results are subsequently used in determining spatial autocorrelation of radio waves through a series of simulations using a simple 2-D ray-tracing method. The correlation function obtained from simulation is then verified against an average correlation function obtained from direct measurements with multiple antennas indoors. In general, the study has found that the spatial autocorrelation of radio waves indoors is similar to that for outdoor environments suggested by Clarke. More specifically, the autocorrelation is presented as a function of separation distance and is used in assessment of multi-antenna system design for indoor applications.

Following this introductory section, a physical model of the channel is described. In Section III, an experimental investigation and a statistical analysis on the number of distinct multiple paths in an indoor environment with their respective directions of arrival are presented. The statistical results are subsequently used as the basis of a simulation study on the correlation of radio waves detected on a number of antennas, which is verified by measurement. Finally, conclusions are drawn on the indoor spatial correlation properties of radio waves.

MODEL OF INDOOR MULTIPATH CHANNELS

Consider a transmit-receive system operated indoors, with a single antenna employed at the transmitter and a planar M -element antenna system at the receiver. Suppose the M -element antenna is positioned on a horizontal plane, with each element being omnidirectional. In addition, let us assume that the dimension of the multi-element antenna is sufficiently small and the location is sufficiently distant from both the transmit antenna and the surrounding wall such that the radio waves can be regarded as planar rather than spherical, even for those waves reflecting off the walls or other objects toward the receive antenna. Considering only wave trajectories on the horizontal plane and simply assuming that the channel coherence bandwidth is greater than the transmission bandwidth, the space-time channel response can be expressed in vector form to incorporate the SIMO (single-input multi-output) nature of the channel:

$$\mathbf{h}(t) = \begin{bmatrix} h_1(t) \\ \vdots \\ h_M(t) \end{bmatrix} = \sum_{n=0}^{N(t)-1} r_n(t) e^{j\theta_n(t)} \mathbf{s}(\psi_n(t)) \quad (1)$$

where t represents observation time, $h_m(t)$ represents the scalar channel response associated with the m -th element at time t , $r_n(t)$ and $\theta_n(t)$, $\psi_n(t)$ denote the time-varying magnitude, phase and direction of arrival (DoA) of the n -th multipath, respectively, and $N(t)$ denotes the time-varying number of multipaths. The DoA-dependent vector $\mathbf{s}(\cdot) = [s_1(\cdot), \dots, s_M(\cdot)]^T$ is the so-called spatial signature of the multi-element antenna. The time variable t can be easily translated into moving distance d by assuming a velocity of the movement so that by assuming static conditions the channel response can also be expressed as a function of horizontal coordinate (x, y) within the room:

$$\mathbf{h}(x, y) = \sum_{n=0}^{N(x,y)-1} r_n(x, y) e^{j\theta_n(x,y)} \mathbf{s}(\psi_n(x, y)) \quad (2)$$

with all of the other variables being as previously defined.

The number of paths represents the number of wave trajectories with significant energy that arrive at the antenna. The magnitude and phase of a multipath altogether depend on the complex-valued path gain, which incorporates the effects of wave propagation through the medium as well as reflection by the walls and other objects taken into account through complex reflection coefficients. The DoA, measured in azimuth with respect to a reference zero direction, depends on the positions of the transmit and receive antennas relative to the walls and the objects scattered around in the room. It is commonly agreed upon in the literature on multi-element antennas that the larger the angular spread of the wave arrival, the lower the correlation of received signals among different antenna elements. The achievement of this condition is important in assuring optimum gain in a space diversity system or maximum accuracy in beam-forming using adaptive array antenna system [5][6].

The spatial correlation of signal levels at points separated in space by a distance Δ at a position (x, y) in a room can be measured and evaluated using a linear antenna array with uniform spacing d , where Δ is an integer multiple of d . Firstly, channel response vector at that position $\mathbf{h}(x, y)$ are measured at the output of the M -element antenna. The spatial correlation $\rho(\Delta, x, y)$ is subsequently computed as follows, with all of the other variables as previously defined:

$$\rho(\Delta, x, y) = \sum_{m=1}^M \frac{1}{M-m-1} h_m(x, y) h_{m-\Delta/d}^*(x, y) \quad (3)$$

The coefficient $1/(M-m-1)$ serves to realize triangular windowing and compensates for the limitation in the number of elements. Symbol * denotes complex conjugation.

NUMBER OF PATHS AND DIRECTION OF ARRIVAL

Measurement

Characterization of number of paths and direction of arrival is carried out through a measurement campaign in a 3.74 m × 9.27 m room with wooden benches and metal shelves [8]. The measurement system, consisting of a pair of disccone antennas and a network analyzer, is shown in Figure 1. The experimental study is performed at 1.7 GHz. For detection of different multipath components arriving from various azimuthal directions, the receiver employs the synthetic array approach combined with the well-known MUSIC (multiple signals classification) algorithm first suggested by Schmidt [9]. The synthetic planar array structure consists of a rectangularly arranged 5 × 5 points, from which eight forward/backward 4 × 4 subarrays can be formed as shown in Figure 2, thereby allowing detection of a maximum of eight resolvable paths [10]. The number of resolved paths itself is determined by applying the MDL (minimum description length) criterion [11]. The array structure and dimension are so chosen only to fit the measurement area into the available spaces in the room. The floor plan of the measurement site is shown in Figure 3. All of the 28 measurement links are line-of-sight, which might imply that the detected paths will consist of one dominant direct path and a number of weaker paths, and that this condition will incur high spatial correlation of radio waves. However, the measurement results reported later show that this is not necessarily the case.

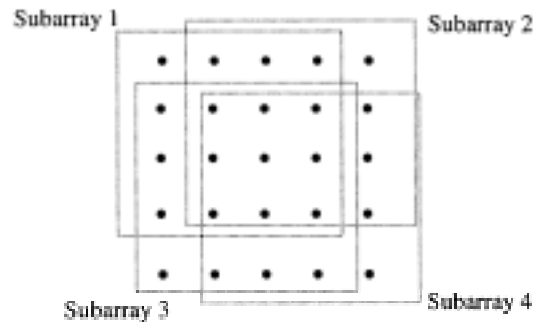

Figure 2. Structure of the synthetic planar array with its subarrays

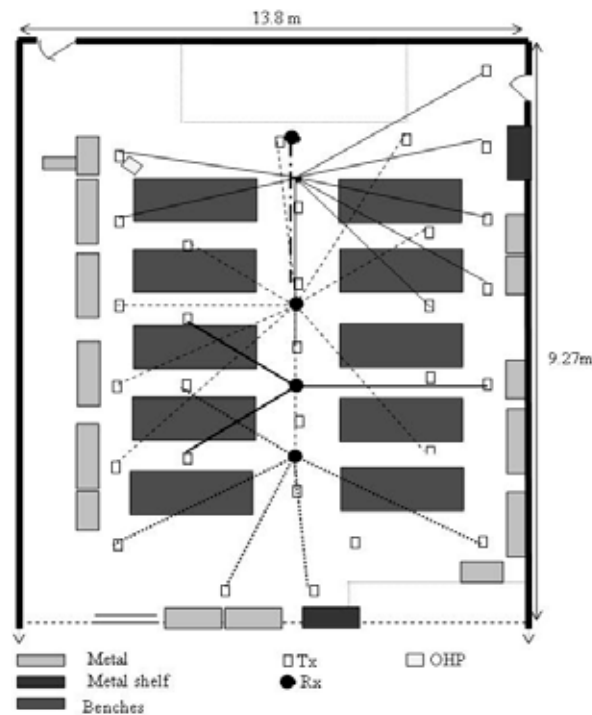

Figure 3. Floor plan and links configuration of the DoA measurement

Results

Only in one out of the 28 links the MUSIC algorithm fails to detect exactly eight paths, which is the maximum detectable number of paths by the array structure employed. This leads to reasoning that a minimum of eight radio paths occur in indoor environments. By setting the direct path to 0° azimuth, histogram of the azimuthal direction of arrival of radio waves is given in Figure 4. It is clear that due to line-of-sight conditions, the direct path is always in existence. The other paths, however, appear from the histogram to take random directions, with uniform distribution within the range of -180° to 180° being a strong possibility. However, the existence of the direct path does not necessarily mean the received power is mostly delivered through it. This phenomenon is shown by the probability density of RMS

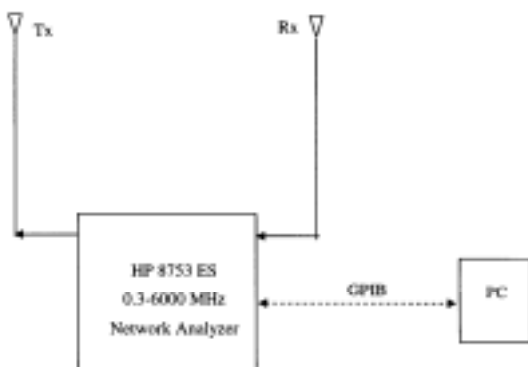

Figure 1. The measurement system

(root mean squared) values of the angular spread presented in Figure 5. The RMS angular spread can be as high as 100° , whereas 14% of the measured links show RMS spread of 80° . This is indicative of the near-uniformity of power deliverance over the whole azimuth range of radio wave arrival.

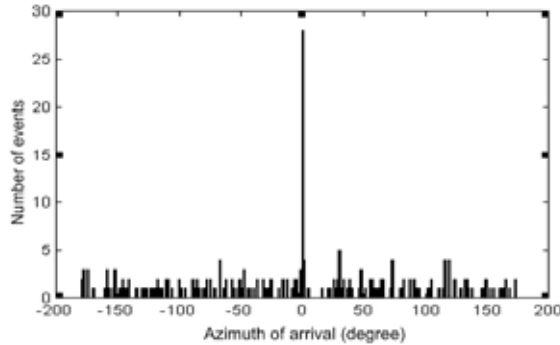

Figure 4. Histogram of azimuths of arrival

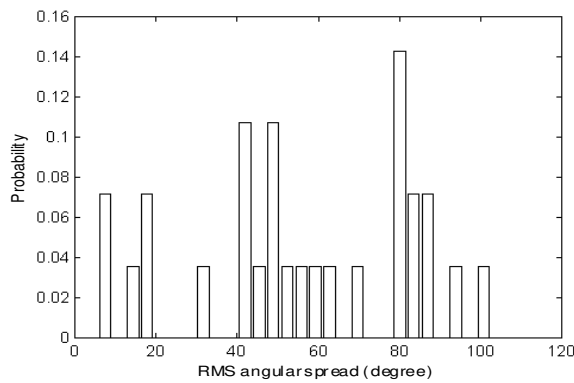

Figure 5. Probability density of RMS angular spread

SPATIAL CORRELATION

DoA Statistics-Based Simulation and Measurement

From the previous section it can be summarized that in indoor LOS (line-of-sight) environments as typified by the selected measurement locations there must be at least eight radio paths including a direct path and at least seven other paths with uniformly distributed directions of arrival, through all of which the received power is delivered uniformly. This finding is adopted in determining the paths of radio waves arriving from a transmitter to a group of antennas linearly arranged with half wavelength spacing [12]. A direct path is generated at all times, whereas seven others are reflected or scattered by objects surrounding the receive antennas from uniformly-distributed random directions. In addition, the coefficients of reflection are made random with magnitude being uniformly-distributed in $(0, 1]$ and phase being similarly so in $(-180^\circ, 180^\circ]$. The floor plan and scenarios of the radio links are presented in Figure 6. The layout of the

hypothetical room resembles a rectangle of $5\text{ m} \times 10\text{ m}$ dimension. It is considered interesting to learn the effect of both the orientation of the linear array and that of the transmit-receive direct path relative the length (the longer dimension) of the room. It is therefore decided that the simulation must look into this issue.

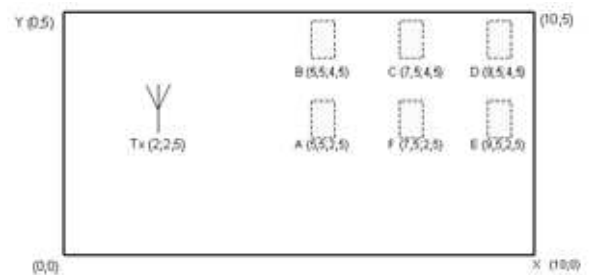

Figure 6. Scenarios of simulated radio links

Firstly, a scenario in which the transmit antenna is fixed at coordinate $(2, 2.5)$ is examined (see Figure 6). Four positions of the receive array are considered, namely A, B, D and E. Also, the linear array is oriented either north-south (N-S) or east-west (E-W) at each position considered. Correlation coefficients of signals received by separate antennas are depicted in Figure 7 for the two array orientations. It can be observed that:

- In general, when the array is oriented North-South the correlation coefficient decreases rapidly with antenna separation distance. When the receive array is at position A, the correlation is less than 0.5 for inter-element spacing greater than half a wavelength. However, for East-West orientation of the receive array, the decrease of correlation with separation distance is more gradual, for position A reaching as low as merely 0.5 at a distance of 0.4λ , rising up to 0.65 at about 0.6λ , before diving back below 0.5 at 0.7λ . For the conditions in which the receive array is located close to the wall, i.e. positions D and E, the slope is even slower, reaching about 0.75 after a wavelength separation distance.
- When the receive array is at position A, which is approximately in the center of the room, the correlation is the lowest among those at various separation distances.

Measurements are made of signal magnitudes received by linearly arranged antennas with spacing of multiples of half a wavelength by again applying the synthetic array concept and employing the same measurement system and locations reported in Section III. The results are used to compute the correlation coefficients of received signals on separate antennas with the two types of orientation [13]. The coefficients at separation distances of half and one wavelength are superposed on the simulation results

in Figure 7. It is clear that the measured coefficients are close to the corresponding values from simulation, especially for the case of position A, for both types of receive array orientation.

Figure 8 depicts the correlation coefficients for the case where the transmit antenna is randomly placed anywhere in the room, thus averaging out the effect of the fixed location in the previous simulation, with the receive array being oriented either North-South or East-West. As a result, the curves of the coefficients for different positions of receive array lie closer to one another when compared to those shown in Figure 7. The effect of different orientation on the correlation is also less significant, both N-S and E-W showing oscillation with minima near 0.4λ and 0.9λ and the values almost never exceeding 0.4 for separation distances beyond 0.3λ . Superimposed on the experimental correlation curves in Figure 8 is Clarke's correlation curve [6] arising from the assumption of the two-dimensional circularly distributed random scatterers and which can be computed from the absolute value of the Bessel function $|J_0(2\pi d/\lambda)|$.

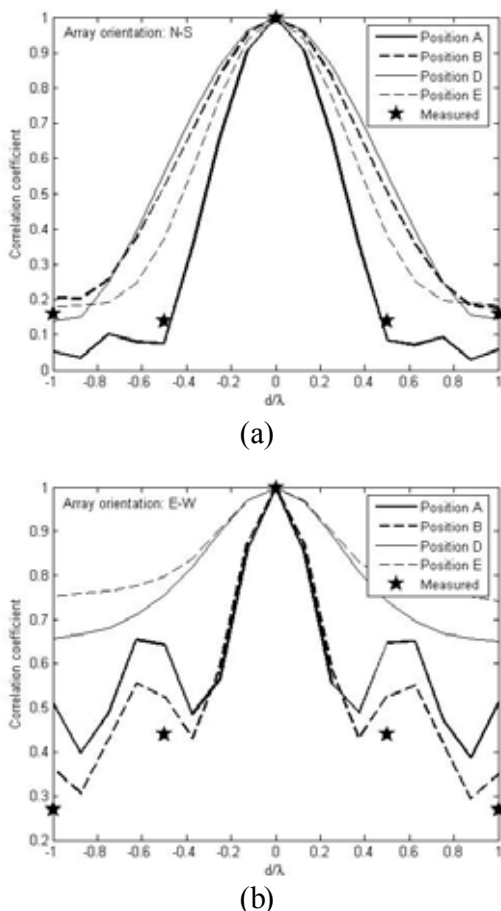

Figure 7. Correlation coefficient of received signals with respect to spatial separation of antennas for a fixed transmit antenna and two orientations of receive array: (a) North-South and (b) East-West

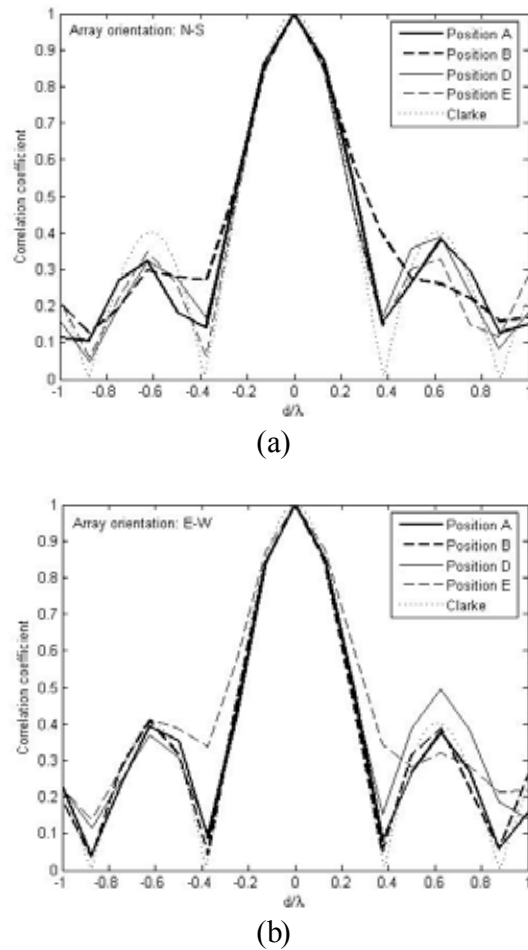

Figure 8. Correlation coefficient of received signals with respect to spatial separation of antennas for various positions of transmit antenna and two orientations of receive array: (a) North-South and (b) East-West

DISCUSSION

From the above results it can be observed that the form of spatial correlation function depends on the position of the multi-element antenna and its orientation with respect to the length of the room and the trajectory of the LOS path. Generally the closer the array to the center of the room, the more rapid the decline of the correlation with spacing regardless of the antenna orientation. When the antenna orientation is considered, however, the results are almost the same for all antenna positions in the room when the linear array is oriented approximately perpendicular to the LOS path. Whereas for antennas oriented approximately in parallel with the LOS path, the decreasing slope in the correlation function is slower. This observation leads to a conclusion that the best orientation of a multi-element linear array to obtain low correlation is the one perpendicular to the LOS path.

From the evaluation of spatial correlation averaged over various positions of transmitter, it is also found that the resulting correlation function is very close to the one arising from two-dimensional circularly-spread scatterers model proposed by Clarke. However, it can still be observed that antennas oriented perpendicular to the length of the room results in on average more rapidly decreasing correlation with spacing compared to those oriented in parallel. It can also be concluded that the best inter-element spacing for a linear array is approximately 0.4λ , but any spacing larger than 0.3λ generally results in correlation less than 0.4, which is sufficiently small for all practical purposes [6]. This is very much relevant with the desire to incorporate a built-in compact array into a small terminal for indoor wireless application.

CONCLUSIONS

Spatial correlation function of radio waves indoors has been studied through several stages. Firstly, the statistics of number of arriving waves and their directions of arrival are investigated through a series of measurements in LOS conditions. It is found that in general at least eight paths of arriving waves exist at any position indoors including the LOS path and that despite the LOS conditions the energy of the arriving waves is spread over a large angular spread, promising a low spatial correlation.

The results are then used in simulation to study the correlation function, which is then verified by field measurement, with the final aim of determining a strategy to optimize receive antenna array orientation and location so as to obtain adequately uncorrelated signals on the elements. The findings include that in general an array positioned near the center of the room will experience more rapidly decreasing correlation with spacing, which is a desired trait. In addition, a linear array oriented perpendicular to the length of the room in general shows better characteristics in terms of faster slope of correlation compared to the one in parallel with the length of the room. Finally, for practical implementation of antenna arrays in small terminals for indoor wireless applications, it is suggested that the inter-element spacing be made 0.3λ in the least.

Acknowledgement

A number of fellow faculties and students of the Department of Electrical Engineering of Institut Teknologi Sepuluh Nopember were involved in the measurement campaigns and subsequent analyses, including Dr. A. Affandi, Mr. Suwadi, Mr. Endro-

yono, Ms. N. A. Siswandari, and Mr. H. Hermitch. Their contribution is gratefully acknowledged.

REFERENCES

- [1] J. H. Winters, "On the Capacity of Radio Communication Systems with Diversity in a Rayleigh Fading Environment", *IEEE Journal on Selected Areas in Communications*, vol. 5, no. 5, June 1987, pp. 871-878.
- [2] D. Gesbert, M. Shafi, D. Shiu, P. J. Smith, A. Naguib, "From Theory to Practice: An Overview of Space-Time Coded MIMO Wireless Systems", *IEEE Journal on Selected Areas in Communications*, vol. 21, no. 3, April 2003, pp. 281-302.
- [3] G. Foschini, "Layered Space-Time Architecture for Wireless Communication in a Fading Environment When Using Multi-Element Antennas", *Bell Labs Technical Journal*, 1996.
- [4] J. B. Andersen, "Array Gain and Capacity for Known Random Channels with Multiple Element Arrays at Both Ends", *IEEE Journal on Selected Areas in Communications*, vol. 18, no. 11, November 2000, pp. 2172-2178.
- [5] J. C. Liberti, T. S. Rappaport, *Smart Antennas for Wireless Communications*, Prentice-Hall 1999.
- [6] W. C. Jakes, *Microwave Mobile Communications*, IEEE Press, 1974.
- [7] G. Hendranto, D. D. Falconer, M. S. El-Tanany, "Characterization of 29.5 GHz Broadband Indoor Radio Channels Using a Steerable Receiving Antenna", *Wireless Communications Conference*, Boulder Colorado, August 1997, pp. 205-209.
- [8] P. Handayani, *Statistical Characterization of Radiowave Angles of Arrival at 1.7 GHz in Indoor Environment* [in Indonesian], Master's Thesis, Institut Teknologi Sepuluh Nopember, Surabaya, 2003.
- [9] R. O. Schmidt, "Multiple Emitter Location and Signal Parameter Estimation", *IEEE Trans. on Antennas and Prop.*, March 1996.
- [10] Y.-M. Chen, "On Spatial Smoothing for Two-Dimensional Direction of Arrival Estimation of Coherent Signals", *IEEE Trans. on Signal Processing*, vol. 45, No. 7, July 1997.
- [11] M. Wax and I. Ziskind, "Detection of The Number of Coherent Signals by The MDL Principle", *IEEE Trans. on Acoustics, Speech, and Signal Processing*, vol. 37, No. 8, August 1989.
- [12] H. Hermitch, *Spatial Correlation Coefficients of Radiowaves and Diversity Gain in Indoor Environments for Applications in Multi-Antenna Communication Systems* [in Indonesian], Under-

- graduate Final Project, Institut Teknologi Sepuluh Nopember, Surabaya, 2003.
- [13] N. A. Siswandari, *Spatial Correlation Analysis of Indoor Radio Propagation Channels at 1.7 GHz Using a Synthetic Planar Array Antenna* [in Indonesian], Master's Thesis, Institut Teknologi Sepuluh Nopember, Surabaya, 2003.